

BRVKENTHAL

ACTA MVSEI

XI. 4

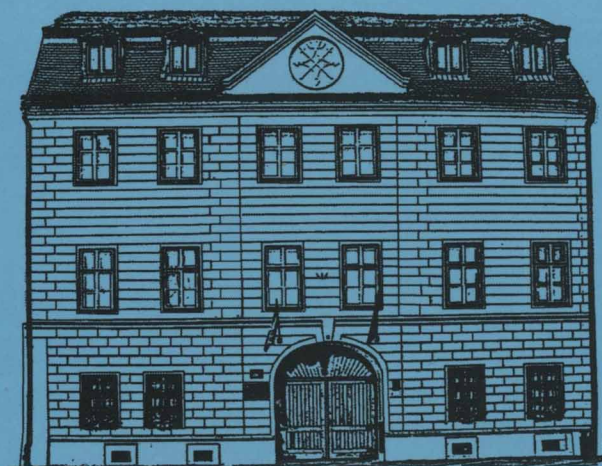

PUBLICATIE  
MUZEULUI  
NATIONAL  
BRUKENTHAL

2016

# BRVKENTHAL. ACTA MVSEI

## XI. 4



**MINISTERUL CULTURII**  
**MUZEUL NAȚIONAL BRUKENTHAL**

**BRVKENTHAL**  
**ACTA MVSEI**

**XI. 4**

Sibiu / Hermannstadt, 2016

EDITOR IN CHIEF: Prof. Univ. Dr. Sabin Adrian LUCA

SECRETARIAL REDACTION: Dr. Anca NIȚOI  
Dr. Daniela DÂMBOIU  
Dr. Ioan TĂUȘAN  
Iulia-Maria PASCU

MEMBERS OF THE BOARD: Dr. Raluca-Maria TEODORESCU  
Dr. Alexandru SONOC  
Dr. Constantin ITTU  
Dr. Rodica CIOBANU  
Ana Maria MESAROȘ  
Dr. Dorin BARBU  
Dr. Dana HRIB

ASSOCIATED MEMBERS TO THE BOARD:

Prof. Dr. Docent Theodor Anton NEAGU (Member of the Romanian Academy)  
Prof. Univ. Dr. Ioan-Aurel POP (Member of the Romanian Academy)  
Prof. Univ. Dr. Paul NIEDERMAIER (Member of the Romanian Academy)  
Prof. Univ. Dr. Conrad GÜNDISCH (Universität Oldenburg - Germania)  
Prof. Univ. Dr. Erika SCHNEIDER-BINDER (Universität Karlsruhe, Bereich  
WWF Auen Institut, Germany)  
Prof. Univ. Dr. Zeno-Karl PINTER ("Lucian Blaga" University Sibiu)  
Prof. Univ. Dr. Rudolf GRÄF ("Babeș-Bolyai" University Cluj Napoca)  
Prof. Univ. Dr. Nicolae SABĂU ("Babeș-Bolyai" University Cluj Napoca)  
Dr. Valentin MUREȘAN (Brukenthal National Museum, Sibiu)

ISSN: 1842-2691



MUZEUL  
NAȚIONAL  
BRUKENTHAL

**Editura Muzeului Național Brukenthal**

Începând cu anul 2009, revista a fost indexată în bazele de date internaționale astfel:

**2009 – INDEX COPERNICUS** <http://www.journals.indexcopernicus.com/karta.php?action=masterlist&id=4759>

**2010 – EBSCOHOST** <http://www.ebscohost.com/titleLists/tnh-coverage.htm>

**2012 – SCOPUS** <http://www.elsevier.com/online-tools/scopus/content-overview>

**2015 – ERIH PLUS** <https://dbh.nsd.uib.no/publiseringskanaler/erihplus/periodical/info?id=484924>

Începând din anul 2011, publicația este vizibilă și pe platforma editorială **SCPIO** (<http://www.scipio.ro/web/brukenthal.acta-musei>).

Starting with 2009, the publication is indexed in the following international date-bases:

**2009 – INDEX COPERNICUS** <http://www.journals.indexcopernicus.com/karta.php?action=masterlist&id=4759>

**2010 – EBSCOHOST** <http://www.ebscohost.com/titleLists/tnh-coverage.htm>

**2012 – SCOPUS** <http://www.elsevier.com/online-tools/scopus/content-overview>

**2015 – ERIH PLUS** <https://dbh.nsd.uib.no/publiseringskanaler/erihplus/periodical/info?id=484924>

Starting with 2011, the publication is to be found on **SCPIO** editorial platform (<http://www.scipio.ro/web/brukenthal.acta-musei>).

Orice corespondență referitoare la această publicație rugăm a se adresa la:

Muzeul Național Brukenthal, Piața Mare 4-5, 550163, Sibiu. **Tel:** +40/269/217691, **Fax:** +40/269/ 211545, **E-mail:**

[iulia\\_m\\_pascu@yahoo.co.uk](mailto:iulia_m_pascu@yahoo.co.uk); **Website:** [www.brukenthalmuseum.ro](http://www.brukenthalmuseum.ro)

Autorii își vor asuma întreaga responsabilitate pentru informația de specialitate din materialele trimise, care vor fi supuse procesului de *peer review*, ale cărui detalii pot fi consultate la <http://www.brukenthalmuseum.ro/publicatii/01.htm>.

**Ghidul pentru autori se regăsește pe website: <http://www.brukenthalmuseum.ro/publicatii/01.htm>.**

Please send any mail or messages regarding this publication at:

Brukenthal National Museum, Piața Mare 4-5, 550163, Sibiu. **Phone number:** +40/269/217691; **Fax** +40/269/211545;

**E-mail:** [iulia\\_m\\_pascu@yahoo.co.uk](mailto:iulia_m_pascu@yahoo.co.uk); **Website:** [www.brukenthalmuseum.ro](http://www.brukenthalmuseum.ro)

The entire responsibility for the specialized information of the article's content is to be assumed by the author; all materials will be submitted to a peer review process. The details can be found at [http://www.brukenthalmuseum.ro/publicatii\\_en/01.htm](http://www.brukenthalmuseum.ro/publicatii_en/01.htm).

**The guide for the authors can be found at: [http://www.brukenthalmuseum.ro/publicatii\\_en/01.htm](http://www.brukenthalmuseum.ro/publicatii_en/01.htm).**

## TABLE OF CONTENTS

Dana Roxana HRIB	<i>Brukenthal National Museum in 2015: a Chronicle of Restoration Exhibitions and Events</i> .....	543
Polixenia Georgeta POPESCU, Ruxandra Ioana STROIA, Maria FOTA, Radu SCHULLER	<i>Interdisciplinary Collaboration for Evaluating of the Conservation and Restoration State of Cultural Composite Assets</i> .....	547
Dana STANCOVICI	<i>The Restoration of a Mosaic Fragment at Bizere Monastery, Arad</i> .....	559
Ioan MUNTEAN	<i>Recovery Restoration Reunification</i> .....	575
Mirel-Vasile BUCUR	<i>Digital Radiological Investigation Applied of Icons on Wood Panel Restored by the Project “Museikon. A New Icon Museum Revitalizes a Historical Monumental Building Restored in Alba Iulia”</i> .....	587
Saveta-Florica POP, Márta Júlia GUTTMANN, Iulia-Maria PASCU	<i>Portable XRF Applied to Icons on Wood. Case Study of Five Icons from Cluj Metropolitan Museum</i> .....	597
Florian PREDA	<i>8 Day Crystal Ball Desk Clock</i> .....	607
Călin BOBIC	<i>The Restoration of a Freemason Sword</i> .....	621
Cristina Maria DĂNEASĂ	<i>The Methodology Used FOR Restoration of Carved and Gilded Ornaments from Saint Ekaterina Church in Bucharest</i> .....	627
Ioan BRAI	<i>Restoring Two Table Clocks from the Collection of the Brukenthal National Museum</i> .....	633
Constantin SCĂRLĂTESCU Cristina MIHU	<i>Restoration of the Painted Layers on the Left Royal Door from The Iconostasis of the Big Royal Church in Târgoviște, Dâmbovița County</i> .....	643
Ilie MITREA Talida- Diana ORIAN	<i>In Front of the Samovar</i> .....	651
Cristina Daniela SCĂRLĂTESCU	<i>Degradations of the Art Objects on Wooden Supports in the Collections of the Brukenthal National Museum Due to Improper Conservation and Restoration Interventions</i> .....	659



## **BRUKENTHAL NATIONAL MUSEUM IN 2015: A CHRONICLE OF RESTORATION EXHIBITIONS AND EVENTS**

**Dana Roxana HRIB\***

**Abstract:** *The present study is a synthetic presentation of Brukenthal National Museum's cultural offer in the field of restoration during 2015.*

**Keywords:** *Brukenthal National Museum, restoration, 2015.*

**Rezumat:** *Articolul de față constituie o prezentare sintetică a ofertei culturale a Muzeului Național Brukenthal în domeniul restaurării, pe parcursul anului 2015.*

**Cuvinte cheie:** *Muzeul Național Brukenthal, restaurare, 2015*

### **1. Permanent exhibitions<sup>1</sup>**

*New permanent exhibition at the 1<sup>st</sup> Floor in Brukenthal Palace:*

Project inside the 2017 Brukenthal Bicentennial program, the works at the 1<sup>st</sup> Floor in Brukenthal Palace developed a three-folded concept focused on the original Reception Rooms at the facade, rooms presenting the interior atmosphere in the late 18<sup>th</sup> c. and the early 19<sup>th</sup> c. and thematic rooms.

The project involved the participation of the restoration specialists from Brukenthal National Museum's Restoration Laboratories at all levels employed by the setting of the new exhibition, from conservation and restoration works to curatorial endeavor.

During 2015 the new exhibition was open in the north wing, while the rest of the project concluded in 2016<sup>2</sup>.

### **2. Temporary exhibitions<sup>3</sup>**

Result of a long and very elaborate process, the exhibitions presenting restored items from the Museum collection are special events. In 2015,

Brukenthal National Museum's cultural agenda enjoyed the opening of such an exhibition as part of a larger project that met with a great appreciation from both the public and the specialists.

#### **a. Exhibitions at the Museum's locations:**

*The Magic of Restoration* (Casa Albastră/Blue House, Multimedia Hall, 11.08-30.09): organized in partnership with CTS Romania and the Directorate for Culture Sibiu, the exhibition displayed pieces from Brukenthal National Museum collections: paintings, old books, graphic works, weapons and firearms, silverware, Neolithic and Dacian pottery, polychrome wood furniture, items made from stone, leather, etc. The exhibits illustrated the complexity of the restoration work, each being displayed together with a poster presentation showing the object before, during and after the restoration process.

#### **b. Online exhibitions:**

*The Magic of Restoration*

[http://www.brukenthalmuseum.ro/index2.php/virtuale/expo\\_1](http://www.brukenthalmuseum.ro/index2.php/virtuale/expo_1)

### **3. Restoration events organized by the Museum**

*40 Years of Scientific Restoration in Brukenthal Museum* (Casa Albastră/Blue House, Multimedia Hall, 11.08): the anniversary event aimed especially to celebrate the restoration specialists who usually work in anonymity and to emphasize the complexity of their work that intermingle science and art. Besides the exhibition and the exhibition catalogue, the event also included a

---

\* Brukenthal National Museum, dana.hrib@brukenthalmuseum.ro,

<sup>1</sup> The short descriptions of permanent exhibitions are selected from the texts given by the curators for public information.

<sup>2</sup> [http://www.brukenthalmuseum.ro/europeana\\_en/etaj/index.htm](http://www.brukenthalmuseum.ro/europeana_en/etaj/index.htm)

<sup>3</sup> The short descriptions of temporary exhibitions are selected from the texts given by the curators for public information.



diploma awarding ceremony attended by more than 70 restoration specialists, current and past employees of Brukenthal Museum.

#### **4. Published materials of historical subject**

##### **Exhibition catalogues:**

\_Dorin Barbu (coord.), *Magia restaurării: 40 de ani de restaurare științifică* (Sibiu, Editura Muzeului Național Brukenthal, 2015, Index ISBN 978-606-93765-9-1, 132 pagini)

The catalogue is also available online on [http://www.brukenthalmuseum.ro/pdf/Magia\\_restaurarii.pdf](http://www.brukenthalmuseum.ro/pdf/Magia_restaurarii.pdf)

## REFERENCES

- Dorin Barbu (coord.), *Magia restaurării: 40 de ani de restaurare științifică* (Sibiu, Editura Muzeului Național Brukenthal, 2015, Index ISBN 978-606-93765-9-1)  
M N Brukenthal: Raport de Activitate 2015  
<http://www.brukenthalmuseum.ro/pdf/Raport%202015.pdf>  
[www.brukenthalmuseum.ro](http://www.brukenthalmuseum.ro)



## INTERDISCIPLINARY COLLABORATION FOR EVALUATING OF THE CONSERVATION AND RESTORATION STATE OF CULTURAL COMPOSITE ASSETS

Polixenia Georgeta POPESCU PhD\*, Ruxandra Ioana STROIA\*\*, Maria FOTA\*\*\*, Radu SCHULLER\*\*\*\*

**Abstract:** *Interdisciplinary collaboration represents the desideratum for the conservation and restoration of the mobile cultural heritage that ensures qualified interventions based on the expertise of those involved, complemented by careful documentation and pertinent scientific analysis. In case of cultural composite assets the interdisciplinary cooperation is indispensable.*

*In this article there are rendered the applied working methods used by the involved team (three restorers of different competence fields and a scientist conservator) to assess the state of conservation, physicochemical analysis and restoring of some composite cultural assets belonging to the collections of the Brukenthal National Museum. The selected pieces were a real challenge due to their material structure and diversity of degradation, generating the carrying out of specific restoring interventions. Study of pieces and interventions were made by the active participation of all concerned who, under time pressure have developed communication skills and team work to capitalize skills for recognizing the specific degradation posed by parts and to properly assess these. Suitable solutions for restoring were found through a real creativity exercise so that interventions were linked to each single support, making also possible the achievement of an equilibrium for all these interventions.*

**Keywords:** *composite cultural assets, dance card, conservation and restoration, optical microscopy, interdisciplinary collaboration*

**Rezumat:** *Colaborarea interdisciplinară reprezintă dezideratul în ceea ce privește conservarea și restaurarea patrimoniului cultural mobil, fiind o caracteristică ce asigură realizarea unor intervenții avizate, bazate pe expertiza celor implicați, completată de documentarea atentă și analiza științifică pertinentă. În cazul bunurilor culturale compozite, colaborarea interdisciplinară este indispensabilă. În articol sunt ilustrate metodele de lucru utilizate de echipa implicată (trei restauratori cu competențe pe domenii diferite și un investigator chimist) pentru evaluarea stării de conservare, analiza fizico-chimică și restaurarea unor bunuri culturale compozite din colecțiile Muzeului Național Brukenthal. Piese selectate au reprezentat o provocare datorită structurii lor materiale și a diversității degradărilor, fapt ce a impus efectuarea unor intervenții specifice pentru restaurarea lor. Studiul pieselor și intervențiile au fost realizate prin participarea activă a tuturor celor implicați care, sub presiunea timpului și-au dezvoltat abilitățile de comunicare și de lucru în echipă pentru valorificarea competențelor în recunoașterea aspectelor specifice degradărilor pe care le prezentau piesele și pentru evaluarea corectă a acestora. Soluțiile adecvate pentru intervențiile de restaurare au fost găsite printr-un adevărat exercițiu de creativitate astfel încât intervențiile să fie corelate pentru fiecare suport în parte și să se poată fi realizat și un echilibru al tuturor acestor intervenții.*

**Cuvinte-cheie:** *bunuri culturale compozite, carnet de bal, conservare-restaurare, microscopie optică, colaborare interdisciplinară*

### A. Introduction

In article there are presented, by case studies, conservation-restoration interventions and preliminary physicochemical investigation carried out for different kinds of constituent materials (paper,

leather, textiles) of a group made up of five composite cultural assets – dance cards - which are part of an impressive collection of History Museum “Casa Altemberger ” of Sibiu.

National Brukenthal Museum, Sibiu; \* polixenia.popescu@gmail.com, \*\* ruxandrastroia@gmail.com, \*\*\*fota\_maria\_laboratory@yahoo.com, \*\*\*\* sradu84@yahoo.com

The dance cards books were used as fashion accessories during society balls. Ladies were writing down the schedule of dances (names of gentlemen they intended to dance with and dance sequence). Dancing cards lie back in the eighteenth century but they began to be widely used starting with the nineteenth century. They were worn as accessories for ball gowns and along in years dance cards became real works of art, often being made out and decorated with precious materials. Dance cards, by historical information they contain - date, location, names of those who attended the event, sponsors, titles of most popular songs and dances of the time – are now true witness objects of Sibiu community life.

## B. Methodology of carried out interventions

B1. Description and presentation of objects conservation status:

While entering the laboratory, the dance cards were evaluated, in the first stage upon physical integrity, photographically documented and studied in terms of historical-documentary value. In existing data sheet record of objects<sup>1</sup> there were filled observations and issues regarding characterization of the constituent materials identified by the working team and diagnosis of the conservation status (Fig.1).

For the diagnosis of each dance card and hence their conservation status there were recorded the noticeable degradations with the naked eye. Degradation once found, they were then evaluated using optical microscopy, a non-destructive technique which has proven extremely effective in the field of the subsequent conservation-restoration interventions.

### 1. Dance Card (no Inventory: M 1641/9227).

Dance card shaped like a handbag from the Sibiu ball dated February 3, 1894 has a leather cover, which is lined with cream-colored silk, decorated with vegetal motives and reinforced metal corners. Central MC printed monogram, golden colour on the cover and the second cover there is entered the date of 3 February 1894. The dance card has a silk thread attached, with two metal balls, a hook and a tassel. The two sheets inside the booklet are containing the following: "page 1: *Hermannstadter / Casino-ball / 3 February 1894*; page 2: *Wallzer /*

*Polka Frank / Quadrille / Polka Mazur / Polka schnell / quadrille / Pause*; page 3: *Cotillon / Polka franc./Quadrille / Wallzer / Polka schnell / Quadrille*; Page 4: *Workshop / F.W Papke / Wien*" (Teodorescu, R.M., Frâncu R.M 2014, 27).

Onto the surfaces of the leather and paper support of the dance card, during the laboratory procedures, there were visible deposits of adhering dirt, dust deposits, deposits of fatty stains of unknown origin. Also, they could easily be seen the effects of photochemical degradation (slightly yellowed paper) and physical mechanical degradation of the object (weakening of silk thread and slight stiffening of the leather).

### 2. Dance Card Fancy Dress Ball in Sibiu, March 6, 1888 (no Inventory: M 1646/9244a).

Dance card foreground made of burgundy velvet is shaped like a wooden picture frame. In the middle there is places a bone carved part rendering an interior scene with six characters. The reversed support is of cardboard, over which was applied by sticking a burgundy velvet cover. To the dance card there is attached a cord and a red silk tassel. The inside of the dance card includes two pages (page 1-2) with the text " *Casino- Costume- Ball in Hermannstadt / am 6 Marz 1888 / TANZ-ORDUNG and dances list: page 1: "Vor der Ruhe./ Walzer./ Polka tremblante./ 1 Quadrille./ Polka – mazur./ Walzer./ 2 Quadrille./ Csardas./ Romana./ Walzer./ 3 Quadrille"*; page 2: " *Nach der Ruhe. / Cotillon. / 4 Quadrille. / Polka - Mazur / Polka tremblante. / 5 Quadrille. / Walzer. / Polka schnell.*" (Teodorescu, Frâncu 2014, 26)

The conservation status of the dance card on entering the laboratory was as follows: the paper pad was showing clogged dirt and on edges traces of adhesive used for sticking on the silk pad. On the top edges of the fabric there were visible migration of colour and reddish-brown stains. On the folding area, along a part of about 3.5 cm, there is a rupture without loss of material. The red silk tassel showed adherent dirt and the frame was disrupted by age.

### 3. Dance Card (no Inventory: M 1643/ 1 – 8751/51).

The dance card comes from a workshop located in Sibiu and represents a dance order made of cardboard. On the cover there is an illustrated a women in folk costume belonging to the epoch. On the lower part of the cover there is recorded: "Burger

<sup>1</sup> The data sheet records were issued by Ms. Olga Besliu, curator and custodian of the collection

Ball". Inside the booklet there are two sheets with following text: *page 1*: "Vor der Ruhe. / Polonaise / Walzer / Polka mazur/ Pas de patineurs/ I.Lancier/ Boston/ Blumen Walzer II. Quadrille/ Boston"; *page 2*: "Nach der Ruhe/ (D.W.) Walzer/ Polka francaise/ Boston /III Quadrille / Carina / Walzer / Polka mazur/ IV. Quadrille/ Boston".

Onto the surface of the dance card, while being taken over by the laboratory there were visible slight deposits of adherent dirt and dust, effects of the photochemical degradation (slightly yellowed paper) and physical mechanical degradation of the object (upper corner slightly folded).

#### 4. Dance Card (no Inventory: M 1643/2 - 8751/58).

The Dance Card from Women Association Ball of 1899 came from a Transylvanian workshop. On the over there is a man and a woman dancing, dressed in Saxon costumes. The pair of dancers is flanked by a floral ornament (swirl sunflower leaves and flowers). On the left stalk there is a character with a tense bow, probably Cupid aiming the two dancers. Above the characters there is written the text "Frauenverein-Ball". On the top of the dance card, into a round medallion, there is a building and below the text "Ev. MAEDCHENSCHULLE". On the bottom of the cover, framed by three masks it is recorded the date, 1899. On the reverse of the ball dance card there are drawn a mask, a violin, a mandolin, tied by ribbons, the year 1899 is written down. "The booklet contains in the interior the dances list: *Danz Ordnung / page1*: "Vor der Ruhe: / Walzer / Polka Mazur / Polka francaise / 1. Quadrille / Walzer / Polka schnell / Polka Mazur / 2. Quadrille / Polka schnell; *page 2*: "Nach der Ruhe: / Walzer / Polka francaise / 3. Quadrille / Polka Mazur / Polka francaise / 4. Quadrille / Walzer / Polka alle drei" (Teodorescu, Frîncu 2014, 27)

The conservation status of the ball dance card when taken over by the laboratory was: the paper pad showed light deposits of adherent dirt and dust submissions this area light and dust and dirt and there were visible effects of photochemical degradation (slightly yellowed paper).

#### 5. Dance Card (no. Inventory: M 1654)

The dance card, dated February 8, 1913 was manufactured in a workshop from Sibiu and the provenance is from "Town Ball". On the cover, in a frame, there is a man in dressed according to the

epoch, having a sword. On the cover there is written the text: "Burger- Ball". The dance card contains two pages with following content: *page 1*: "Danzordnung/ burger- Ball des Vereins zu Gusten des/ Deutschen Frauenheimes/ 8 Februar 1913/ Georg Haiser, Schmiedgasse".

In the interior of the booklet is the dance list: *page 2*: "Vor der Ruhe: / Polonaise/ Walzer / Polka mazur / Pas de patineurs / I.Lancier / Boston/ Blumen- Walzer/ II. Quadrille/ Boston"; *page 3*: "Nach der Ruhe: / Walzer D.-W. / Polka francaise / Boston / III Quadrille / La Carina/ Walzer / Polka mazur / IV. Quadrille / Boston".

When taken over by the laboratory, the paper pad showed light deposits of adherent dirt and dust submissions as well as effects of photochemical degradation (slightly yellowed paper).

#### B2. Physicochemical investigation: study by optical microscopy of surfaces and support materials.

The physicochemical investigation helped to establish the correct diagnosis, methodology and appropriate work techniques for conservation-restoration interventions through the correct identification of constituent materials of these dance cards that are composite cultural assets and at the same topic this article, by highlighting their degradation.

For the study of objects there was selected a classical technique, namely optical microscopy, which allowed the observation and evaluation of the support areas and assessed their degradation. The analysis of support surfaces was accomplished with a stereo research microscope Leica S8 APO, the microstructure of constituent materials being was observed in reflected light (CNR-ISTEC 2011). The stereomicroscope was equipped with a digital camera, Leica DFC 290, which made possible the taking over of the marked image. Micrographs (captured images) were obtained at a magnification of 40x, the digital processing allowing a supplementary magnifying and hence the observation of details that proved to be very useful for subsequent stages, namely in conservation-restoration interventions.

As a result of the optical microscopy study of support surfaces a similar problem for all parts was identified, so that for exemplification in the article there were presented only the results in case of purse shaped dance card from Sibiu Ball, dated February 3, 1894 (no inv. M 1641/9227) (Fig. 2).

By microscopic study there were recorded details of the conservation status of the object, in photomicrographs presented in (Fig. 3) being visible details of some degradation (abrasions, loss of support material), characteristics of the constituent materials of ornaments book Ballroom (degradation of silk thread), characteristics of constituent organic materials of decorations on the dance card (details of the skin and ornamentation manner). Also, photomicrographs made visible details of the "gren" (the characteristic look of the upper tanned leather) which allowed the identification of the type of leather, namely cattle hide leather. The identification of the leather type of the dance card support was done by comparing with leather samples related to restoration laboratory casuistry and by comparison of the characteristic look tanned neat's leather with available images in specialty literature (Chiriță 1983, 62).

### **B3. Conservation-restoration interventions:**

Conservation-restoration interventions were performed without disassembly of the piece. Correlated to the diagnosis set for the whole group of dance cards there were chosen mild treatments, less invasive, optimally achieved during successive stages, to protect the functional unit of the objects.

All pieces in this group required specific conservation and restoration interventions. Preliminary to interventions, cleaning tests were conducted. Interventions were: dry cleaning, wet cleaning, reattachment, moistening and matching the original form accordingly to the object's feedback, strengthening and securing detachments.

The stages of dance cards restoring process were photographically documented in (Fig.4, Fig.5 Fig.6). There are shown images of objects before and after the intervention, as well as details during their restoration.

Materials and tools used for restoring the objects were: special abrasives of different finesse for dry cleaning of different support materials belonging to objects subject of interventions: special erasers for cleaning the leather surface (CCI Notes 2016, 13/16), soft appropriate brushes for detaching deposits from paper surface (Government of Canada, 2016), distilled water, ethyl alcohol, isopropyl alcohol, solvent for leather, starch adhesive, carboxymethyl cellulose, polyvinyl acetate, anionic detergent, filter paper, Japanese paper, cotton sticks, non-woven material.

### **B4. Conclusions:**

Due to the team effort, by blending experience and best practices of real diversity in order to get optimal results for elucidating interdisciplinary aspects and differential intervention procedures on selected ball dance cards, these were stabilized and returned back to exhibitions.

During 2014, the ball dance cards were included into an itinerant exhibition entitled "Saxon dresses and ornaments and their representation in the paintings of the period".

### **Acknowledgement:**

We are saying thank you to Ms Cristina Muntean for the English version of this article.

**REFERENCES**

- CCI Notes, 2016 CCI Notes *Mechanical Surface Cleaning of Textiles* (2010) 2016-07-12. Available from: <http://canada.pch.gc.ca/eng/1439925167385> [15 July 2016]
- Chiriță 1983 Chiriță Gheorghe, *Tehnologia pieilor și blănurilor*, vol.1, Editura Tehnica București, 1983
- Cioară 2011 Cioară Lucica, *Structura și designul țesăturilor. Elemente de proiectare*, Ed. Performantica Iași, 2011, ISBN: 978-973-730-782-8
- CNR-ISTEC 2011 CNR-ISTEC, *Optical microscopy* 2011. Available from: <http://www.istec.cnr.it/index.php/eng/resources/expertises/95-microstructure-and-texture/196-microscopia-ottica-en> [15 July 2016]
- Government of Canada, 2016 Government of Canada *Basic care – Paper documents and newspaper clippings*, 2016-04-11. Available from: <http://canada.pch.gc.ca/eng/1454533345295> [15 July 2016]
- Teodorescu, Frîncu 2014 Teodorescu Raluca Maria, Frîncu Raluca Maria, 2014, Veșminte, *Podoabe săsești și reprezentarea acestora în pictura vremii: catalog de expoziție*, Editura Muzeului Național Brukenthal, 2014, ISBN 978-606-93508-5-0



## LIST OF ILLUSTRATION





1. 1 Table with description and characteristics of objects.
2. Details of the support surface, ball dance card no. inv. M 1641/9227):
  - a). and b) Jacquard fabric technique with silk thread.
  - c). detail of double twisted cord (silk).
  - d). detail of tassel- plush thread (silk).
3. Microphotographs (40x) support- ball dance card no. inv. M 1641/9227:
  - a). support surface with visible fat deposits and stains of unknown origin.
  - b). “gren” (characteristic aspect of upper tanned leather).
  - c). ornament (patch), metallic gold.
  - d). monogram printed detail.
4. Table with photo documentation of ball dance card (no inv. M 1641/9227) before, during and after restoration.
5. Table with the photo documentation of ball dance card (no inv. M 1646/9244a), before, during and after restoration.
6. Table with photo documentation ball dance cards, inventory numbers: M 1643/1 - 8751/51 M 1643/2 - 8751/58 and M 1654 before, during (details on inside paper backing) and after restoration.

Note: For preparing the photographic documentation of objects there contributed Mr. Alexander Olănescu (objects and photos before and after restoration), Ms. Ruxandra-Ioana Stroia and Mr. Radu Schuller (photos during restoration objects), Ms. Polixenia Georgeta Popescu (microphotograph objects).

## LISTA ILUSTRĂȚILOR

1. 1 Tabelul cu descrierea și caracteristicile obiectelor.
2. Detalii ale suprafeței-suport a Carnetului de bal, nr. inv. M 1641/9227):
  - a). și b). țesătura în tehnica jacquard cu fir de mătase.
  - c). detaliu șnur –fir dublu răsucit (mătase).
  - d). detaliu ciucure –fir plușat (mătase).
3. Microfotografiile (40x) ale suprafeței-suport din piele a Carnetului de bal nr. inv. M 1641/9227:
  - a). suprafața suport pe care sunt vizibile depuneri de substanțe grase și pete de origine necunoscută.
  - b). grenul (aspectul caracteristic al feței pieilor tăbăcite).
  - c). ornament (întăritură) metalic auriu.
  - d). detaliu monogramă imprimată.
4. Tabel cu documentația foto a Carnetului de bal (nr. inv. M 1641/9227) înainte, în timpul și după restaurare.
5. Tabel cu documentația foto a Carnetului de bal (nr. inventar: M 1646/ 9244a), înainte, în timpul și după restaurare.
6. Tabel cu documentația foto a Carnetelor de bal cu numerele de inventar: M 1643/1 – 8751/51, M 1643/2 – 8751/58 și M 1654, înainte, în timpul (detalii cu hârtia-suport din interior) și după restaurare.

Nota: La realizarea documentației fotografice a obiectelor au contribuit: dl. Alexandru Olănescu (fotografiile obiectelor înainte și după restaurare), d-na Ruxandra-Ioana Stroia și dl. Radu Schuller (fotografiile din timpul restaurării obiectelor), d-na Polixenia Georgeta Popescu (microfotografiile obiectelor).

No	Label	Dating	Materials, techniques, sizes
1.	Ball dance card No inv. M 1641/9227 	February 2, 1894	-mineral tanned leather, pointed and golden in the area of inscriptions -fabric in Jacquard technique (silk). "Jacquard fabrics are fabrics with large connected drawings by tens, hundreds or thousands of threads made on looms equipped with Jacquard mechanisms for joint work" (Cioară 2011, p.133) -paper -cardboard -double twisted cord and plush tassel (silk) -metallic ornamentations -imprinted, golden colour ornamentation -hand tailored and manufactured Sizes: 53/100/10 mm
2	Ball dance card No inv. M 1646/9244a 	March 6, 1886	-wood -paper -cardboard -bone -double twisted cord and tassel (silk) -connecting velvet fabric (silk) -carving, turning -hand tailored and manufactured Sizes: 50/69/15 mm
3	Ball dance card No inv. M 1643/1 – 8751/51 	Period 1880-1900	- cardboard - paper - printing, cutting - manufactured Sizes: 116/67/5 mm
4	Ball dance card No inv. M 8751/58 	1899	-cardboard -paper -printing, cutting - manufactured Sizes: 105/65/5 mm
5	Ball dance card No inv. M 16454 	February 8, 1913	cardboard -paper -printing, cutting - manufactured Sizes: 117/67/5 mm

1. Table with description and characteristics of ball dance cards

Ball dance card  
No inv. M 1641/9227



a.

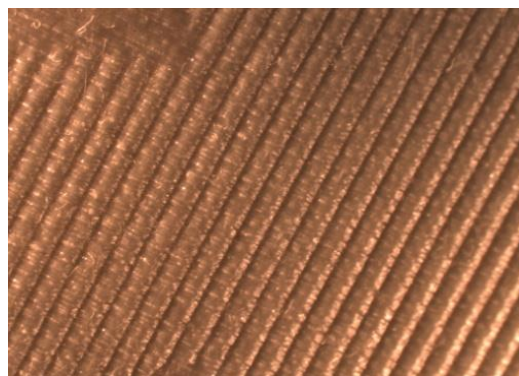

b.

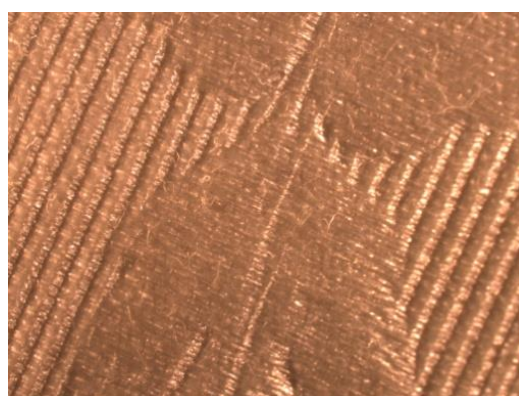

c.

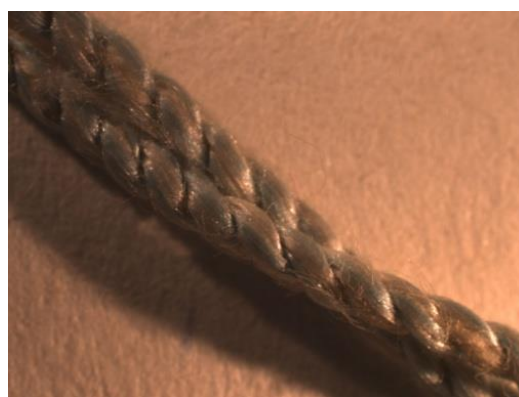



d.



2. Details of the support surface of ball dance card No inv. M 1641/9227). a). and b). fabric in Jacquard technique with silk threads c). cord detail –double twisted cord (silk). d). detail tassel–plush threads (silk).



3. Microphotographs (40x) of the leather support surface belonging to ball dance card No inv. M 1641/9227:
- a). support surface with visible fat deposits and stains of unknown origin.
  - b). “gren” (characteristic aspect of upper tanned leather).
  - c). ornament (patch), metallic gold.
  - d). monogram printed detail.

Before restoration	Detail during restoration (interior of ball dance card)	After restoration
Ball dance card No inv. M 1641/9227 		

4. Table containing photographical documentation about ball dance card (No inv. M 1641/9227) before, during and after restoring

Before restoration	Detail during restoration	After restoration
Ball dance card No inv. 1646/9244a  	  	

5. Table containing the photographical documentation about ball dance card ‚Masked Ball’ from Sibiu, March 6, 1888 (No inv. M 1646/ 9244a), before, during and after restoration.

Before restoration	Detail during restoration on paperback from the interior of the ball dance card	After restoration
<p>Ball dance card, No inv. M 1643/1 – 8751/51</p> 		
<p>Ball dance card, No inv. M 1643/2 – 8751/58</p> 		
<p>Ball dance card, No inv. M 1654</p> 		

6. Table containing the photographical documentation about ball dance cards, inventory numbers: M 1643/1 – 8751/51, M 1643/2 – 8751/58 and M 1654, before, during (details with the interior paperback) and after restoration.



## THE RESTORATION OF A MOSAIC FRAGMENT AT BIZERE MONASTERY, ARAD COUNTY<sup>1</sup>

**Dana STANCOVICI \***

**Abstract:** : the present study aims the description of preservation and restoration modalities of a fragment from the floor mosaic of the monastery discovered in Frumușeni village, Fântânele parish, Arad county, monument known in the archaeological literature as Bizere monastery. The restored area is part of the nave's pavement, the first panel from the south. For the restoration of this fragment of mosaic, due to the quite high number of missing tesserae, was necessary to manufacture replicas from rivers stones and/or epoxide resin mixed with marble powder and pigment.

**Keywords:** conservation, restoration, Bizere Monastery, mosaic, tesserae

**Rezumat:** prezentul articol are care ca scop descrierea modalității și etapelor de conservare și reconstituire a unei părți a mozaicului de paviment din biserica din satul Frumușeni, com. Fântânele, jud. Arad, monument cunoscut în literatura de specialitate ca și mănăstirea de la Bizere. Aria reconstituită face parte din mozaicul navei acestei biserici, din primul panou de la sud. Pentru recompunerea scenei respective, datorită numărului relativ mare de tesere lipsă, au fost confecționate replici similare morfologic din pietre de râu și din rășină epoxidică amestecată cu praf de marmură și pigment.

**Cuvinte cheie:** conservarea, reconstituire, mănăstirea Bizere, mozaic, tesere

By combining the practical and utilitarian aspects with the function of decoration, mosaics are provided with a dual nature: the practical aspect is interdependent on the contemplative one. It is an element which can shine or be confused with the background. A history of the mosaic, an apparently modest chapter of ornamentation integrated in the vast domain of architecture and arts history, is going to surprise us through a great deal of information, which the viewer can approach, thus in mosaics he will have the possibility to discover vivid and vibrated reflections of the epochs represented<sup>2</sup>. A durable material, the mosaic has successfully resisted in time. The „mosaic” word emphasizes something beautiful, an art manifesting in various forms.

Within the frames of the Romanian archaeological research, the summer of 2003 represented the first

unveiling of medieval mosaics fragments. The place of discovery is located along the route between Arad and Lipova and it is integrated in the commune of Frumușeni. In this zone, on the south of Mureș Valley, one can still see the trail marked by a former branch of the river, which once used to form an island, chosen to settle a monastery in the Middle Ages. The point is known as Hadă (*island* in Turkish) or the Fountain of the Turk and today, on the surface, it highlights a more important detail, the brick remnants of a tower and a fountain made of wrought stones.

Until the initiation of the archaeological research, which facilitated the finding of mosaics, the historians stated that in the Middle Ages this was the place where they conducted a monastery known in the documents as Bisra/Bistra and especially Bizere. The source of this name, similar to the one of a village vanished in the close neighbourhood, is unknown.

Besides the pavement mosaics, the site from Frumușeni also comprises other unique items of the historical patrimony related to Romania or Central and Eastern Europe. Thus, it appears, almost exclusively, due to the opportunities provided by the

---

<sup>1</sup> For a Romanian language shorter version of this paper see Stancovici 2013.

\* Banat Museum Timișoara. E-mail: danastancovici@yahoo.com

<sup>2</sup> For a brief but yet comprehensive history of mosaic see Fawcett 2001, pp. 13-16.



latest archaeological research. It is about a major insertion of local and early artistic history which unexpectedly changes the knowledge of the genesis, ambient, diffusions and gained performances. The Lower Mureş valley actually becomes a major element of European artistic geography at the beginnings of the second Christian millennium (Burnichioiu, Rusu 2006, p. 20).

The importance of a settlement such as Bizere for the cultural patrimony of the western Romania, the archaeological research, the pavements' curative conservation works (carried out in 2009) and the existence of a rather high number of original *tesserae* taken out through excavations (isolated findings) during archaeological campaigns, facilitated the restoration of a fragment from the pavement of that monastery.

The complexity of the issues regarding the topic of preservations, the degradation of external profiles and the degradations of the drawings' outlines, as well as the decision to re-bury the excavated floor, as a temporary measure or permanent solution approached in long-term conservations, have left the issue referring to the mosaics in the Bizere Monastery open.

The restoration of a mosaic fragment represented an incursion in the mosaic technique, from the *tesserae*'s layout mode to their production and attempt to remake the mosaic starts, as all these levels suggest a continuation of the curative in situ conservation of the mosaics from Bizere.

### Materials and technique

Art historian Ileana Burnichioiu emphasizes that "there are no hints to suggest the provenance of the artisans, who have made these mosaics, besides the stylistic characteristics, and they are not directly connected to any site making pavements at the end of the 11<sup>th</sup> century and the next one. However, one can notice general formal analogies in some ornaments, both in parietal painting and mosaics and in miniatures, sculptures or goldsmith. The bestiary elements populating the nave's mosaic, the uniform disposal of colours within the limits of drawings, the *opus tessellatum sectile* combination, besides motives once noticed in the repertoire of late antiquities then in the one of Byzantine art, send us to a space of Romanic style, which assimilated a lot from the last repertoire" (Burnichioiu, Rusu 2006, p. 20). The mosaics' surfaces are "technically uniform, as they are made from the *tesserae* whose height varies between 2 and 5 cm; they have the same white background obtained from quartzite, which replaces the white marble complex, and

apparently it displays natural chromatic combinations of red, dark greyish blue and black, white, light blue, ochre and dark green" (Burnichioiu, Rusu 2006, p. 9). All patterns are well defined through simple strings of dark greyish blue and green *tesserae*. The technique is a combination of *opus tessellatum* and *opus sectile*<sup>3</sup>.

The large amounts of fragments, specific to *tessera* pavements, emerged as isolated findings, in the site's different sections – are related to the pavement decorations of the Bizere Monastery.

Regarding the work technique, they applied the manual carving/cutting of stones, followed by polishing and grinding.

### The *tesserae*' preservation condition

There are occlusions, fissures, erosions on the surface of stones. The *tesserae* exhibit incrustations of mineral deposits, deposits of mineral substances crystallized on their surface, changes of the stone's colour. On some *tesserae* they preserved remnants of the original mortar (cement), mixture made of sand, chalk, brick powder, which is a mixture of light ochre and reddish pigment.

Given the fact that the *tesserae* underwent a first lavation under a normal pressured flush of water, at the archaeological site they were immersed in a solution of Biocleaner and water. After the sample cleaning, the immersion time was set to 30 min. They were washed under a flush of water and then left to dry.

The reconstituted scene is part of the nave's mosaic. Selected from the first southern panel whose diagonals are made of an alternation of white squares and others of various dark brick-red shades, it comprises a galloping quadruped, displaying a human trunk and the head of a dog/wolf. Its inferior part, including its feet and head, is suggested sideways, and its trunk and eye, with a well-defined eyebrow, are reproduced full-faced. Its both hands, which are stretched, one forward, and the other one backwards, seem to hold something, however, we can read three strings of *tesserae* only on the right hand side, its bust starts with a waistband, and around its neck the clothing item is completed with a V letter shape ornament (see Fig. 1).

The upper part of the scene is completed with a floral ornament achieved in some yellowish white and gray and dark shades of brick-red.

<sup>3</sup> For a very clear and succinct presentation of different types of mosaic styles see Alberti et alii 2013, pp. 1-3.

The first work stage consisted in the execution of some moulds and samples made of different types of materials.

### The silicone rubber mould

The mould beyond the surface of the mosaic was made to support the subsequent research, study and exhibition. They used silicone rubber reinforced with gauze. Twenty four hours later the mould was removed and the surface was cleaned (see Fig. 2).

The existence of the mould provided the possibility to counter-draw the drawing correctly and study the *tesserae*'s disposal thus supporting the procedure approached to restore the mosaic.

### The conversion of the selected scene into epoxide resin

The mosaic's replica was made of epoxide resin provided with some fortifying material combined with calcite (marble powder), in a percentage of 50%, to react for twenty four hours. In order to be fortified the sample needed a wire mesh reinforcement and its insertion into a wooden frame. The chromatic integration (the staining of the surface) was made before its casting, on its negative, with oil colours (see Fig. 3a, 3b).

The drawing was transposed on the tracing paper, whose support was represented by the resin mould (which is integrated chromatically). Then it was copied on the transparent plexiglass foil (see Fig. 4a, 4b).

The plexiglass foil adjustment was done into a wood stand to provide a rigid surface. The mount's frame will be integrated by pouring layers of mortar into the mosaic's structure.

When making the mount they also considered the fact that the restoration of the mosaic was going to be made through a double indirect method.

The double indirect method can be applied when it is important for the author to visualize the surface during the mosaic's assembling process. The *tesserae* are placed face up onto a medium (on the plexiglass surface the *tesserae* are fixed with plasticine), as it is going to appear when the surface is installed. When the mosaic is complete, a binder (Roman cement) is placed on the other side. Then the item is turned upside down and the mounting medium (the plasticine) is carefully removed. Compared to the indirect method, this is a complex technical system and demands the operator's great skills to avoid deteriorations at work. The greatest advantage consists in the operator's possibility to directly control the final outcome of his work es-

pecially when the work's composition is more elaborated.

The reconstitution of the main character succeeds the selection of *tesserae* as the *tesserae*' quantity is not sufficient to completely cover the surface suggested for the restoration (100 x 110 cm.)

Regarding the complete restoration of the suggested image, they experienced different methods to restore the *tesserae*.

### The making of resin *tesserae*'s replicas

The resin *tesserae* were made in silicone rubber mould, which imitated original *tesserae* made in different dimensions.

The composition of the material to be used in restoration by casting it into the silicone rubber was based on an peroxide resin and some fortifying material combined 1/1 with various aggregates (marble powder, stone powder, pigments which are compatible with the resin – oxides) (see fig. 5a, 5b). The hardening time is 24 hours.

### The making of river stones *tesserae*'s replicas

During the mosaics' conservation *in situ* was noticed that in the case of drawing contours and geometric forms they used dark green siliceous stone, river stone or river sandstone, in an uninspired way, which have become highly brittle. This stone was preserved *in situ* only here and there and did not emerge in isolated findings.

It was searched for a formula to integrate some *tesserae* made of another type of stone (sharing similar form, structure and colour). The stone, which used to define the drawings' contour, was replaced when the restoration was done.

Having in mind the specialists' assumptions regarding the origin of the shape stone (Ionescu, Bucur 2011, pp. 103-105), it was tried the manual production of the river stones *tesserae* highlighting some greenish-black textures similar to those in the archaeological site, from the Mures Valley, in the proximity of Frumușeni village (see Fig. 6a, 6b).

During the restoration process, the using the river rock to make the drawings' contour was stopped as this method did not guarantee the exact borders of the mosaic pattern. The stone's irregular peeling did not offer the possibility to get the accurate restoration of the missing *tesserae*, concerning their dimension and form (see Fig. 7).

Another method approached to restore the *tesserae* missing from the original composition, which was finally chosen – is the moulding of decors – by means of *tesserae* in different dimensions onto a

plasticine surface, obtaining a textured surface specific to the mosaic technique (see Fig. 8, 9).

Before its casting, the zone of original gaps was isolated with polystyrene to emphasize the level differences (Fig. 10).

The fixing layer of moulding was achieved in three different stages, in the first two ones they used Roman cement of different grain sizes (Fig. 11a, 11b). The third layer was an adhesive meant to strengthen the surface in the ground. In order to get a higher degree of safety during its manipulation, the adhesive was reinforced with a plastic mesh (plaster mesh) (Fig. 12). After moulding the Roman cement, the plasticine was removed (Fig. 13). The removal of cement surplus and the cleaning of the *tesserae*'s parting was the next step (Fig. 14a, 14b).

**Conservation and final impregnation** (see Fig. 15 for the general aspect of the mosaic's fragment before the final impregnation)

The finally applied treatment was focused on the formation of a protective film covering the mosaic's surface. It was chosen the impregnation with acrylic polymer (Palaroid B-72) as this is resistant to humidity, reduces the water's absorption and preserves the morphological and structural characteristics of the surface and it is reversible (see Fig. 16 for the final aspect of the mosaic's fragment).

This restoration was seen as a modality to facilitate the recreation of the atmosphere and image of a part of the basilica for the sake of the guest public.

The recovery of the exhibition is related to a compulsory popularizing approach to emphasize its importance, activate the necessary resources to finalize the research and, especially, to solve the problems referring to an adequate conservation and reevaluation, a curatorial and touristic one.

## REFERENCES

- Alberti et alii 2013      Alberti, Livia; Bourguignon, Elsa; Roby, Thomas, *Technician Training for the Maintenance of In Situ Mosaics*, The Getty Conservation Institute (Los Angeles), Institut National du Patrimoine (Tunis), 2013.
- Burnichioiu, Rusu 2006      Burnichioiu, Ileana; Rusu Adrian Andrei, *Mozaicurile medievale de la Bizere*, Cluj-Napoca, 2006.
- Fawcett 2001      Fawcett, Jane, *Decorated pavements and floor monuments in European cathedrals and churches*, in *Historic Floors. Their care and conservation* (ed. Jane Fawcett), Oxford, 2001, pp. 1-40.
- Ionescu, Bucur 2011      Ionescu, Corina; Bucur I. Ioan, *Analiza unor roci sedimentare*, in *Mănăstirea Bizere I*, (eds. Adrian Andrei Rusu, Ileana Burnichioiu), Cluj-Napoca, 2011, pag.103-106.
- Stancovici 2013      Stancovici, Dana, *Reconstituirea unui fragment al mozaicului de la mănăstirea Bizere, jud. Arad*, in *Simpozion. Formă, Formare, Sens, Tomul I*, Timișoara 2013, pp. 323-330.

### LIST OF ILLUSTRATIONS

1. The fragment of pavement proposed for restoration
2. The silicone mould rubber. The surface of the mosaic covered by the strengthen silicone rubber
3. a, b: The making of the resin replica
4. a, b: The drawing of the surveying
5. a, b: Reconstitution of the resin tesserae
6. a, b: Reconstitution of the river stone tesserae
7. Detail of the reconstituted mosaic using river stone tesserae
8. The areas made by stamping the surface of the tesserae into plasticine (detail)
9. The areas made by reconstitution using resin tesserae, river stone tesserae and by stamping the surface of the tesserae into plasticine
10. The surface of the mosaic prepared for casting
11. a, b: The aspect of the surface after the first layer of fine roman cement was casted
12. Assembling the armature and the application of the third layer of fixation
13. Details after the primary removal of the cement and plasticine surplus
14. a, b: Cleaning the cement surplus and highlighting of the partings
15. The mosaic ready for the final impregnation and conservation
16. The fragment of mosaic restored

### LISTA ILUSTRĂȚILOR

1. Fragmentul de paviment propus pentru reconstituire
2. Mulajul de cauciuc siliconic. Suprafața mozaicului acoperită de cauciucul siliconic armat
3. a, b: Executarea replicii din rășină
4. a, b: Întocmirea releveului
5. a, b: Reconstituirea teserelor din rășină
6. a, b: Reconstituirea teserelor din piatră de râu
7. Detaliu realizat cu tesere confecționate din piatră de râu
8. Zonele realizate prin amprentarea suprafeței teserelor în plastilină (detaliu)
9. Zonele realizate prin reconstituire cu tesere din rășină, din piatră și prin amprentarea suprafeței teserelor în plastilină (ansamblu)
10. Suprafața pregătită pentru turnare
11. a, b: Suprafața turnată cu primul strat de ciment roman cu granulație fină
12. Montarea armăturii și aplicarea stratului al treilea de fixare
13. Detalii după îndepărtarea primară a surplusului de ciment și a plastilinei
14. a, b: Curățarea surplusului de ciment și evidențierea rosturilor
15. Mozaicul pregătit pentru conservarea și impregnarea finală
16. Fragmentul de mozaic la final



1. The fragment of pavement proposed for restoration



2. The silicone mould rubber. The surface of the mosaic covered by the strengthen silicone rubber



3 a, b. The making of the resin replica

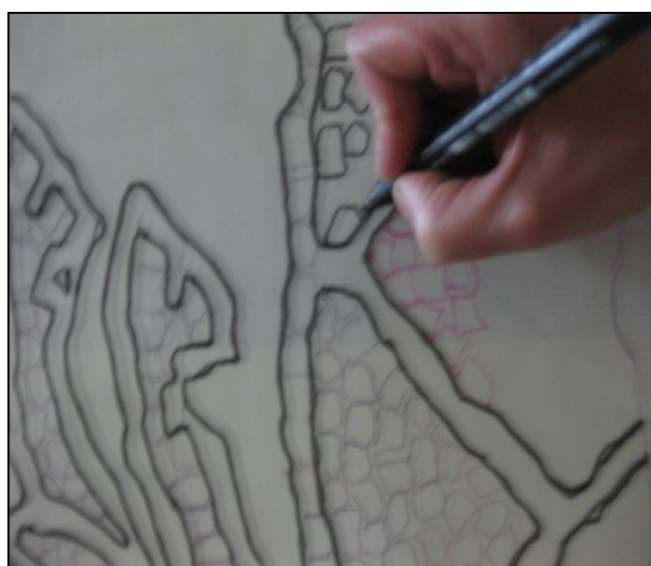

4 a, b. The drawing of the surveying



5 a. Reconstitution of the resin tesserae



5 b. Reconstitution of the resin tesserae





6 a. Reconstitution of the river stone tesserae



6 b. Reconstruction of the river stone tesserae



7. Detail of the reconstituted mosaic using river stone tesserae



8. The areas made by stamping the surface of the tesserae into plasticine (detail)



9. The areas made by reconstitution using resin tesserae, river stone tesserae and by stamping the surface of the tesserae into plasticine



10. The surface of the mosaic prepared for casting

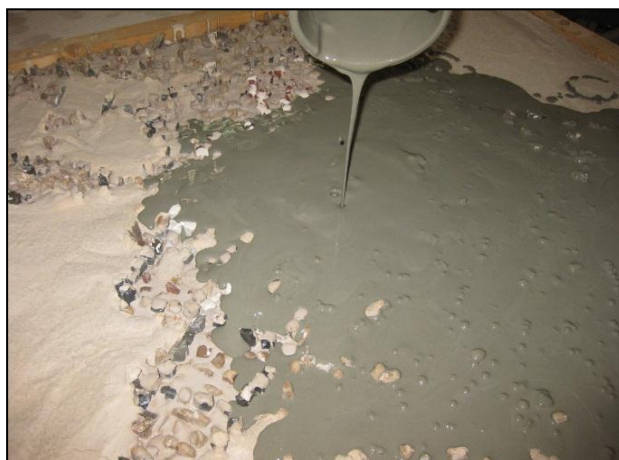

11 a, b. The aspect of the surface after the first layer of fine roman cement was casted

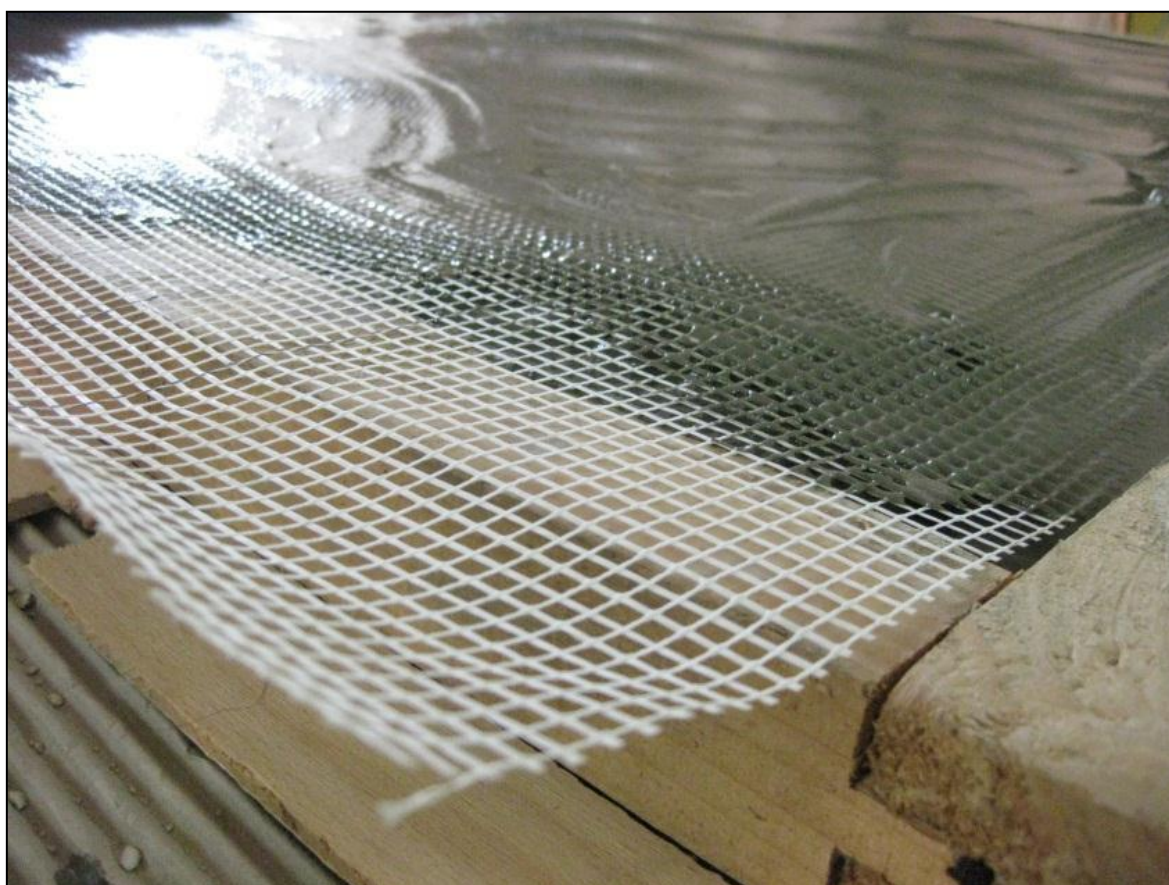

12. Assembling the armature and the application of the third layer of fixation



13. Details after the primary removal of the cement and plasticine surplus



14 a, b: Cleaning the cement surplus and highlighting of the partings



15. The mosaic ready for the final impregnation and conservation



16. The fragment of mosaic restored



## RECOVERY RESTORATION REUNIFICATION

Ioan MUNTEAN\*

**Abstract:** *The old paintings, by Pierre Auguste Bellet, who were decorating the Union Hall of Alba Iulia were partially destroyed during the communist period. Nowadays, when the country is preparing for the centenary of the Great Union, the pieces of the original painting have been recovered, and they entered into a process of restoration. Based on a serious documentation and teamwork, we were able to restore this painting.*

**Keywords:** *Pierre Auguste Bellet, Union Hall . National Museum of the Union in Alba Iulia, reversibility, analogy, restoration, painting.*

**Rezumat:** *Vechile picturi realizate de pictorul Pierre Auguste Bellet, ce decorau Sala Unirii din Alba Iulia au fost parțial distruse în perioada comunistă. În această perioadă când se fac pregătiri pentru sărbătorirea centenarului Marii Uniri, bucățile de pictură originale ce au fost recuperate, au intrat într-un proces de restaurare. În baza unei documentații temeinice și a unei munci în echipă, am putut restaura această pictură.*

**Cuvinte cheie:** *Pierre Auguste Bellet, Sala Unirii, Muzeul Național al Unirii din Alba Iulia, reversibilitate, analogie, restaurare, pictare.*

As a result of a request by the National Museum of the Union in Alba Iulia, we began a restoration project, related to the painting of Pierre Auguste Bellet. This painter decorated, in 1920, the arches and other parts of the so called "Union Hall". These painted scenes are portraits of rulers or outstanding personalities in the history of the Romanian people. This article refers to the process of restoration-reunification of one of the paintings on the arches.

The historical context in which these paintings were made is one of particular importance for the Romanian people, the preparing of the Union Hall for the coronation of King Ferdinand and Queen Mary on October 15, 1922. In the same hall, four years earlier, on December 1, 1918 the act by which Transylvania was united with the motherland was signed. The paintings of Pierre Auguste Bellet were made between those two dates.

Relatively little data is known about the author, ~~Piere Bellet~~. He was born in Galati in 1865 and

passes away in the same town in 1924. It was a known painter in the artistic Bucharest and in the year 1898 we find him on the International Art Exhibition of the "Ileana" Society, alongside the biggest names of fine art in Romania.

Prior to restoration, the state of conservation of the painting was extremely poor, with an unhappy journey through time. This painting, executed in oil on canvas technique, has the shape of an arc, 158 cm wide, 864 cm length and height of 432 cm. From the original work, only a few pieces were saved, five of the twelve portraits. After the instauration of the communist regime, these paintings, as artistic testimonies of the royalist period, were removed and only found a role in the upholster doors and windows. Several pieces were cut from the original canvas and were nailed to the panel doors or window frames. Probably, only the good quality of the canvas led to the reuse of these materials and not directly tossing them into the trash. It is obvious here the total lack of respect - during the communist era- for the artistic work

\* Muzeul Național Brukenthal, Sibiu; e-mail: ioni\_muntean@yahoo.com



dating from the previous political regime. Even if this painting was not an "official" representation any more, they should have opted for conservation of the painting.

The historical figures represented in this painting, according to the brochure of 1922 *Alba-Iulia Descriere istorică și geografică a orașului*, are: Matei Basarab, Vasile Lupu, Șerban Cantacuzino, Constantin Brancoveanu, Dimitrie Cantemir, Grigore Alexandru Ghica, Tudor Vladimirescu, Dimitrie Știrbei Barbu, Gheorghe Bibescu, Mihail Sturdza, Alexandru Ioan Cuza and Carol I. The selection of these figures illustrates the official history of Romania at that time, with an important notice that no historical character from Transylvania is represented here... The selection for the represented rulers was prepared and approved by the ruling political class after the Great Union and not by the artist. The sources of inspiration for these portraits are various representations of these rulers. Some we can easily guess as Tudor Vladimirescu represented by a portrait done by Theodor Amann of Alexandru Ioan Cuza after one portrait of Carol Popp de Szatmari.

Restoration operations were carried out for portraits of the following rulers: Matei Basarab, Vasile Lupu, Grigore Alexandru Ghica, Tudor Vladimirescu and Barbu Dimitrie Știrbei. For the rest of the characters we have conducted documentation, on the basis of the old photography of the painting exhibited in the Union Hall. We encountered two problems for the exact identification of the character or the author's source of inspiration. For Prince Șerban Cantacuzino, mentioned by N. Iorga in his brochure from 1922 we found similar representations with other two rulers: Gheorghe Ștefan and Radu Șerban. The physiognomy, coat and hat are very similar for all three portraits. A second problem was the representation of Prince Mihail Sturdza, where through our research, we discovered an engraving by Constantin Lecca but this has a physiognomy slightly modified as the original painting photo. In this case our model for painting the portrait was the vintage photo. For the rulers: Constantin Brâncoveanu, Dimitrie Cantemir, Gheorghe Bibescu, Alexandru Ioan Cuza and Carol I, things were clear and we used the same sources of inspiration as Pierre Bellet.

The concept of restoration must be understood in a broader framework for this project. Being aware from the outset that these pieces of painting do not represent by far 51% of the original painting, we

decided, however, that we have a duty to intervene and recover all that is possible from it. We had to find solutions for these paintings not to be lost forever, and after their restoration the public to be able to see these artistic testimonies of the Great Union. In the basis of this project two of the principles from the profession of restorer are staying: reversibility and analogy. All restoration work carried out on pieces of the original painting are reversible and the materials and methodology used allows the easily removal of interventions. We've started first the restoration for the three paintings representing the historical figures: Avram Iancu, Decebal and the emperor Traian, and Horia, Closca and Crisan; in this way studying the technical work of the artist, his touch, gestures and the monumental approach. Then we've searched for the sources which may have inspired the artist to achieve these portraits. We also received two historical photographs with the original paintings from the time they were still standing in Union Hall. Unfortunately they are in sepia tones but even so, they were very useful to us. With the help of these pictures we were able to identify the missing characters and their position. These photos were graphically processed, vectorised and a digital sketch was realized, where the existing pieces of this painting were positioned.

The development of the project took place in two different parts, in terms of the type of intervention: a restoration and a second part of painting. Separate operations of the two components of the project were mixed, linked and mutually conditioned. We started the restoration project, as is normal, with comprehensive photo documentation and a slight removal of dust using soft brushes and dust extraction with vacuum cleaner on the back of the painting pieces. We had to construct a new stretcher in order to anchor the painting on it. This was achieved with the help of a specialized company, together with whom we went twice in Alba Iulia to measure and then check the size and shape of the chassis. The large size of the stretcher imposed a modular approach, but this also needs to be resistant to torsion and to have specific features like a retreat slope and tensioning wings. Due to former improper handling cleavages were present on many parts, and we had to consolidate those with an adhesive compatible with the original. Adhesive application was conducted by brush, the painting surface was heated with thermal spatula and then we created pressure with the help of sandbags. The flatness of the painting needed to be restored, especially on the edges of the pieces, where the canvas was

folded and nailed. Then the cleaning tests followed, seconded by the proper cleaning of the painting. The new painting stretcher was assembled and then a new canvas was attached to it, similar to the original. Due to the large sizes of the painting we had to join three pieces of canvas, and during this operation we received the help of our colleagues from the textile restoration sector. After anchoring the canvas on the stretcher we had to mark and position exactly in their places the original parts on the surface. The marked surfaces were treated with BEVA 371 gel and after drying of this we have to remove the canvas from the stretcher. The back of the original pieces was also treated with a film of BEVA 371 and then we conducted the thermoplastic doubling method. Now we have only one large piece of canvas, with the original parts of the painting fixed on their places, and this ensemble needed to be again anchored on the wooden stretcher. The next step was the preparation of empty places on the canvas for the painting, in order to complete the entire image, thus we applied a layer of rabbit glue in concentration of 8% followed by applying two coats of rabbit glue plaster. On the perimeter areas of original pieces of the painting we applied Balsite W+K material, on which a canvas texture was marked, this way the transition between the taller area where the original parts are standing and the rest became more "smooth". On these transit surfaces a thin layer of priming was ensured. Based on a digital sketch, a grid network was made on the empty surfaces so the drawing of the missing characters could take place. Our attention was directed again on the original pieces that have now been grouted, chromatically integrated with watercolour and then a layer of damar varnish was applied. Following extensive discussions on the background of the pieces of original painting, with decorative value, we decided that they will be treated similar with the surfaces to be painted, so to repaint these background areas. At this conclusion contributed the fact that the metallic bronze was degraded differently from one area to another, most likely because of inadequate storage mode, thus requiring extensive chromatic integration. The opinions in the group of restorers were different but in the end we focused on the best possible aesthetic impact of the painting and less to show its troubled history. Anyway, a damar

varnish layer was applied over this background with the important role of allowing reversibility to this operation. After this, we've used the inspiration sources mentioned above, and we started painting the missing portraits. This time the artistic talent of each of us came into the second role and we've tried to "enter" the artistic language of the artist. The portraits were made in analogy with the reference models and we treated this operation like the surfaces that must be integrated chromatically, where not the hand of the restorer is important but the plastic language of the original author. Easier to approach were the dresses of the character's, where the artist has emphasized the graphism of the decorated surfaces. For the background we applied a first layer of red-ochre oil-based colour and then two coats of oil-colour with golden metal powders. Copying the original model of the background we made a cardboard template, which was latter applied of the background using airbrush and burnt sienna oil based colour. Finally an all-round frame with red colour was painted, with approximate 4 cm wide. The final varnishing of the work was assured with a mix of matte Regalrez and glossy Regalrez varnish; this because we wanted to have a satin final surface. After the drying we had to take out again the painting from the stretcher and roll it on a wooden drum with a diameter of 70 cm and a length of 450 cm, to be able to take it out from the workplace. The wooden stretcher was also dismantled piece by piece so it could be transported to Alba Iulia. In the Union Hall the stretcher was mounted again and then the painting anchored back on it. The painting was fixed to the wall using metal screw clamps.

In closing I want to mention the staff who participated in this project. From the painting restoration sector there had participated, in alphabetical order, the following expert restorers: Cristina-Maria Fău, Ilie Mitrea, Ioan Muntean, Andrei Popa and Celestina Florina Romocian. We were helped by our colleagues, expert textile restorers: Camelia Dordea and Simona Maria Stănculescu. We have to thank Mr. Sonoc Alexandru, head of the Art Gallery of Brukenthal National Museum for scientific support in identifying the missing portraits.

## REFERENCES

- Enescu 2000  
Alba Iulia 1922  
Brandi 1996
- Enescu Theodor, „*Scrieri despre artă*”, Editura Meridiane, 2000.  
*Alba-Iulia Descriere istorică și geografică a orașului*, București,  
Cartea Românească, 1922.  
Brandi Cesare „*Teoria Restaurării*”, Editura Meridiane, București,  
1996.

## LIST OF ILLUSTRATIONS

1. Original painting photo, National Museum of the Union, Alba Iulia
2. Measuring the arc painted in the Union Hall, Alba Iulia
3. Identifying the pieces of the original painting
4. Photo documentation
5. Anchoring the new canvas on the stretcher
6. Lining the original pieces
7. Thermoplastic lining method
8. Cleaning the original painting and filling with ground the gaps
9. Retouching
10. For the background we applied a first layer of red-ochre oil-based colour
11. The lost portraits were made with oil-based colours
12. At every step we held extensive discussions within the team
13. Garment patterns transposition
14. The lost portraits were made in analogy with the reference models, painted by Perre Bellet
15. A cardboard template was made after the original background pattern
16. Positioning and application of the template using air brush
17. Detail of completed work
18. Detail of completed work
19. Detail of completed work
20. Detail of completed work

## LISTA ILUSTRĂȚILOR

1. Fotografie de epocă, cu pictura originală din Sala Unirii, Alba-Iulia
2. Măsurarea arcului pictat din Sala Unirii, Alba-Iulia
3. Identificarea bucăților din pictura originală
4. Realizarea documentației fotografice.
5. Îmbinarea și întinderea pânzei de dublare pe șasiu
6. Dublarea bucăților originale de pictură
7. Dublarea la cald și punerea în presă
8. Curățarea picturii originale și chituirea lacunelor
9. Integrarea cromatică a lacunelor
10. Pensularea unui strat de culoare pe zona de fond
11. Realizarea portretelor lipsă s-a făcut în culori de ulei
12. La fiecare pas s-au purtat ample discuții în cadrul echipei
13. Transpunerea modelelor de pe veșminte pe zonele nou grunduite
14. Pictarea portretelor lipsă după modelele folosite de Pierre Bellet
15. După modelul original al fondului s-a realizat un șablon din carton
16. Poziționarea șablonului și aplicarea modelului pe fond cu ajutorul aerografului
17. Detaliu lucrare finalizată
18. Detaliu lucrare finalizată
19. Detaliu lucrare finalizată
20. Detaliu lucrare finalizată



1. Original painting photo, National Museum of the Union, Alba Iulia



2. Measuring the arc painted in the Union Hall, Alba Iulia



3. Identifying the pieces of the original painting



4. Photo documentation



5. Anchoring the new canvas on the stretcher



6. Lining the original pieces



7. Thermoplastic lining method



8. Cleaning the original painting and filling with ground the gaps



9. Retouching



10. For the background we applied a first layer of red-ochre oil-based colour



11. The lost portraits were made with oil-based colours





12. At every step we held extensive discussions within the team



13. Garment patterns transposition



14. The lost portraits were made in analogy with the reference models, painted by Perre Bellet



15. A cardboard template was made after the original background pattern

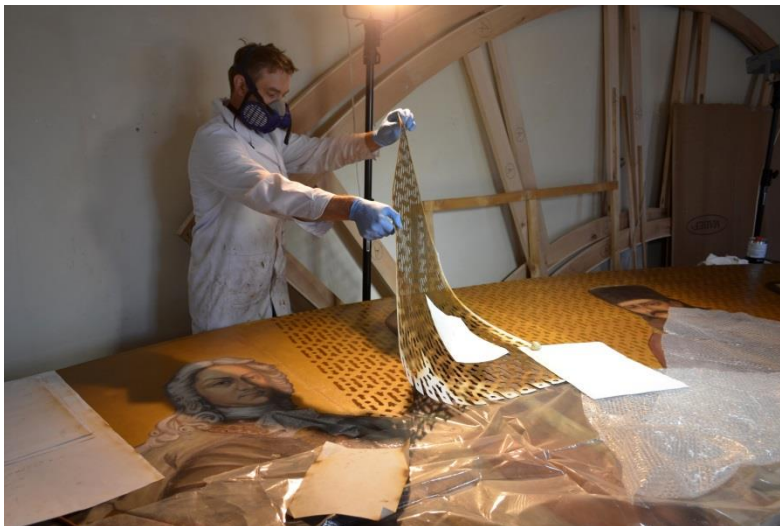

16. Positioning and application of the template using air brush



17. Detail of completed work



18. Detail of completed work



19. Detail of completed work



20. Detail of completed work

**DIGITAL RADIOLOGICAL INVESTIGATION APPLIED OF ICONS ON WOOD PANEL  
RESTORED BY THE PROJECT  
"MUSEIKON. A NEW ICON MUSEUM REVITALIZES A HISTORICAL MONUMENTAL  
BUILDING RESTORED IN ALBA IULIA"**

**Mirel-Vasile BUCUR\***

**Abstract:** *The scientific investigation of heritage assets before of the restoration interventions is a mandatory step and always extremely necessary. Of course, in present we have an extremely wide range of methods and means by which the artifacts of various kinds can be analyzed to determine the state of conservation, detailed knowledge of the materials and, ultimately, to select suitable methods of intervention. Lately, the emphasis is heavily on non-destructive methods or minimum samples of matter and the digital radiography is one of them. In fact, radiography of the heritage assets through traditional means is already a method that has a history of over 100 years, which has proved its usefulness. Modern practice, digital, is one of the methods that make up the range of investigations that we use routinely. This paper aims to present some cases of investigation of the icons on wood with the digital radiography method. Restoration interventions were made in the MUSEIKON project.*

**Keywords:** *icon painted on wood, digital radiography, state of preservation, restoration interventions, radiographic signal, pigments*

**Rezumat:** *Cercetarea științifică a bunurilor de patrimoniu înaintea intervențiilor de restaurare este un pas obligatoriu și întotdeauna extrem de necesar. Desigur, în prezent avem o gamă extrem de largă de metode și mijloace prin care artefacte de diferite tipuri pot fi analizate pentru a determina starea de conservare, cunoșterea detaliată a materialelor și, în cele din urmă, pentru a selecta metode adecvate de intervenție. În ultimul timp, accentul se pune în mare măsură pe metode non-distructive sau eșantioane minime de materie și radiografia digitală este una dintre ele. De fapt, radiografierea valorilor de patrimoniu prin mijloace tradiționale, este deja o metodă care are o istorie de peste 100 de ani, care și-a dovedit utilitatea. Practica modernă, digitală, este una dintre metodele care alcătuiesc gama de investigații pe care o folosim în mod curent. Lucrarea de față își propune să prezinte unele cazuri de investigare a icoanelor pe lemn cu metoda de radiografie digitală. Intervențiile de restaurare au fost realizate în cadrul proiectului MUSEIKON.*

**Cuvinte cheie:** *icoana pictată pe lemn, radiografie digitală, starea de conservare, intervenții de restaurare, semnal radiografic, pigmenți*

## **Introduction**

The project "Museikon. A new icon museum revitalizes a historical monumental building restored in Alba Iulia" is conducted in partnership by the Alba County Council, National Museum of Unification in Alba Iulia, Romanian Orthodox Archdiocese of Alba Iulia and the University of Bergen - Norway. "Museikon" is financed under the Program PA16/RO12 "Preservation and revitalization of cultural and natural heritage", through the EEA Financial Mechanism 2009-2014. The program's operator is the Ministry of Culture by the Project Management Unit, The Managing

Authority – national Point of Contact – Ministry of European Funds.

The overall objective of the project is restoring and revitalizing of the historical monumental building in Alba Iulia, through the establishment of a Museum and cultural facilities. The specific objectives are conservation and restoration of the historical building in Alba Iulia, preparing collections to be exploited in the new Museum, the development of an innovative cultural offerings. The rehabilitation and restoration of historical building includes the strengthening of structural elements: foundations, walls and floors. To make

---

\* Lecturer at Lucian Blaga University from Sibiu, mirel\_bucur@yahoo.com

the building to function as a modern Museum, functional separation is necessary: the South Wing (the actual building of heritage) will be entirely, open to public having spaces with exposure (3 temporary spaces in the basement and 7 permanent spaces at the higher levels), while the North Wing (the recent extension) will be used only by staff, for the needs of functional auxiliary: offices, laboratory restore, storage facilities, changing rooms. Other important activities in the project are: the interventions for the restoration of 52 ranked icons of which 6 belong to the National Museum of Unification and 46 from the Archdiocese's collection, interventions for the restoration of 15 old books from Archdiocese's collection, interventions for the restoration of 15 ranked old books from Archdiocese's collection, including the tabs available on Romanian territory, from the oldest book preserved in Romanian language: *Evangheliarul* printed in Sibiu in 1551, digitizing the entire collections of Museikon inventory to create the database and ranking 2500 cultural goods. The entire collection can be accessed through the website [www.museikon.ro](http://www.museikon.ro) and [www.europeana.eu](http://www.europeana.eu). Annually, a Summer School will be organized for students, museographers and restorers.

Radiography of heritage assets is already a method that has a history of over 100 years, which has proved its usefulness. The digital radiography has imposed itself in the practice of our time, is one method that helps us to analyze what consists range of investigations that we use to establish the state of conservation of the artifacts, for complete knowledge of the component materials and, finally, to selecting appropriate intervention methods. In this article we will limit ourselves to a few considerations of digital radiological investigation applied at four wood icons in the said project.

#### **CRUCIFIXION, Romanian Orthodox Archdiocese - Alba Iulia, Nr. inv. 423.**

Given the size of the icon (37 x 29.5 cm) a single exposure was necessary to give the image the entire surface (Fig. 1-2). To view master image (format .dcm) it was used DicomWorks 1.3.5. which allows export to other formats image file. Usually, we execute an export in .jpeg format for later use in documentation edited in a text format (.doc, .docx) (Bucur, Șofariu 2008, p. 60; Bucur 2009, p. 253-254).

We may see in the radiograph that wood fiber is well evidenced, so we have an appropriate

structure resinous wood, assumption confirmed by B.A. No 25/2015<sup>1</sup>. The radiographic image that can sense are highlighted fissures, cracks and small timber losses recorded in shades of dark gray, almost black. Boring insects attack (according to analysis report 25/2015 *Anobium punctatum*) is insignificant on the painted side. On the back are recorded between 6-48 flight holes /100cm<sup>2</sup> and weakening the wood product. At the corners, we see small timber losses recorded in the image area RX dark colored black (Bucur 2014, p. 357).

The range of tones, from white to black is complex and highlights facts about the nature of the pigments used. The characters face and hands are touches of white lead as radiographic give a signal light. In addition, there are white lead substrate thus amplified signal light over the entire surface by mitigating sharp radiation RX. Red is cinnabar and along the fiber is observed that there is a defect that caused a splintering. Higher wood density and excess primer give us a flare, which detaches the radiological image (Gilardoni et al. 1977, p. 57).

Gaps in radiography paint layers are visible as areas of irregular signal in the range of grays closed. With circular appearance of the paint layers are highlighted losses caused by biological attack (flight holes) and can be seen craclures in the paint layers, which have a characteristic appearance.

#### **HOLY TRINITY IN ONE BODY, Romanian Orthodox Archdiocese - Alba Iulia, Nr. inv. 430**

This piece is painted on a support from spruce<sup>2</sup> with the following dimensions: height 45 cm, width 36 cm. Support is tangential debited, sticks frame are profiled and fastened with adhesive and wooden nails inserted from the front (Fig. 3-4). Wooden nails are constituents and covered by original pictorial layers. In order to obtain an overall picture in this case we performed two exposures. After the master image processing result is spectacular because it revealed the entire composition. In radiography, panel defects are highlighted, respectively overgrown knots and growth areas of branches (Fig. 4).

Observe a strong attenuation of radiation on areas where we have white combinations which suggests the presence of white lead. Areas painted in red can be achieved with lead minium, cinnabar, or mixture of this pigments, as frequently happens (Lang, Middleton 1998, p. 99, 111).

<sup>1</sup> Bucșa, Livia, *Buletin de analiză*, Nr. 25/2015

<sup>2</sup> Bucșa, Livia, *Buletin de analiză*, Nr. 28/2015

To have a clearer situation we used the XRF<sup>3</sup> analysis which confirmed our interpretation of radiographic image and has provided us with additional elements on stratigraphy. Also, there have been confirmed the presence of foil and silver, that we have a red pigment that strong attenuates electromagnetic radiation - cinnabar. In addition, it has been found the presence of white lead and preparation as a filler layer.

**JESUS PANTOCRATOR SURROUNDED BY THE APOSTLES - Ioan from Beriu, Romanian Orthodox Archdiocese, Alba Iulia, Nr. inv. 464**

The icon is painted on a wooden panel, no constituents to strengthen on the back and has attached profiled frame (Fig. 5). Given the size of the wood icon (63 x 51 cm), digital radiography was performed over the entire surface of the piece through four successive exposures, each exposure using the same parameters. The four radiographic images were assembled so that we have the whole picture of the piece (Fig. 6). After analyzing the radiographic image it can be seen that the support consists of two vertical plates uneven, which have been bonded with adhesive collagenic. Wood fiber is also well highlighted and appears as a category of coniferous woods<sup>4</sup>.

The pictorial layers have a different radiographic signal depending on their thickness and composition. Consequently, the radiographic image represent registering compositional elements of the theme. Radiographic image recording areas to shades of white or gray when present white lead (inscriptions in face and hands characters). A similar radiographic signal results in areas where red is used based on minium (garments). Its

<sup>3</sup> XRF - X-ray fluorescence spectrometry is non-destructive analytical method used to investigate the cultural values of ceramics, glass, bronze, precious metal goods, icings, email, obsidian. This method causes excitation of a substance with an X-ray source, which remove electrons from one layer near the nucleus, their place being taken by the electrons on layers removed. This energy exchange is achieved through emission of X-ray fluorescence characteristic that item, providing a note of identification. X-ray source can come from an X-ray tube, from a radioactive source, or may be synchrotron radiation (most appropriate). It is a non-destructive method is suitable for portable devices (Vlad, Niculescu 2013, p. 76-82).

<sup>4</sup> Spruce (*Picea abies*) - Livia Bucșa, *Buletin de analiză*, nr. 24/2015

remarkable that the radiograph reveal the composition of the icon very well, wich is hardly read because of the aged varnish, the adherent deposits or the superficial dirt

**MADONNA WITH CHILD - Gheorghe son of Iacov, circa 1778, Romanian Orthodox Archdiocese, Alba Iulia, nr. inv. 582**

This piece is panited on a stand of softwood of the following dimensions 76.5 x 58 cm. The support is cutted tangetial consisting of two boards that were glued. (Fig. 7)

In this case in order to obatin an overall picture we performed six exposures. The resulting image is spectacular, as the X-rays show that we have a repainting where a golden paint has been applied over the original painiting covering the inscriptions. Also we can mention that the new interventions were inappropriate applied over adherent dirt, old varnish, gaps and fragile areas.

The radiography was quite clear because the icon support is made of resinous wood fiber. At the same time the panel defects are highlighted (Fig. 8). The rods are attached with adhesive on the panel and fixed additionally using wooden pegs, this is also well captured in the radiographic image.

The pictorial layers provides a spectacular image because on the background of the icon are inscriptions made with a red pigment based on lead or mercury. This indicates an inadequate subsequent intervention that took no account of the problematic of the piece, aiming to achieve a relatively obvious aesthetic effect of freshness. The new color was at that time a certain vitality but over time the pigment copper oxidized and dirt adhered further attenuated this effect (Fig. 9-13). It also highlighted lacunar areas.

To have a clearer situation and in this case we used the XRF analysis which confirmed our interpretation of radiographic image and has provided us with additional elements on stratigraphy. It confirmed the presence of Au and Ag foil, that we have a red pigment based on iron oxides, mixed white lead was identified. All determinations by X-ray fluorescence were performed by Phd.

Gheorghe Niculescu and whom we wish to thank. Measurements were performed with a portable Innov-X Systems, Alpha Series.

## Conclusion

Finally mention once again the advantages of digital radiography, the most important being that it is non-destructive, it gives us valuable information on the state of conservation of artifacts about working technique and throws light on some qualitative aspects related primarily of pigments used (Bucur 2009, p. 257). It is worth noting that the image obtained can be further processed like any digital image : adjusting brightness and contrast cropping, converting to another format

(.jpeg, .tiff, .bmp, .png). At the same time we must not forget distance transmission facilities and storage and the possibility of printing (usually heat-sensitive films). For all this, we advocate using this method, we adopted it already for many years, using it routinely as an analysis necessary to penetrate the intimacy of material parts to be restored.

## REFERENCES

### A – Publication

- Bucur 2014 Bucur, Mirel-Vasile, *Date puse în evidență prin radiografia digitală în cazul unor icoane din colecția Arhiepiscopiei Sibiului*, în *Conservarea și restaurarea patrimoniului cultural*, volumul XIII, Iași, Doxologia, 2014, p. 354-373 (ISSN 2286-1459, ISSN-L 2286-1459)
- Bucur 2009 Bucur, Mirel, *Investigația non-distructivă de tip radiologie digitală aplicată în domeniul picturii tempera pe panou*, în *Cibinium 2006-2008*, partea a II-a, Sibiu, Editura „ASTRA Museum”, 2009, p.253-260
- Bucur, Șofariu 2008 Bucur, Mirel, Șofariu, Ciprian, *Noi metode de investigație radiologică pentru piesele restaurate în laboratorul de restaurare pictură din cadrul C.N.M. ASTRA-Sibiu*, în *Revista muzeelor*, nr. 1, București, 2008, p. 60-64
- Șofariu 2006 Șofariu, Ciprian-Radu, Șofariu, Simona, *Radiologia în artă și în arheologia modernă*, în *Sibiul Medical*, Volum 17, Nr. 4, Sibiu, 2006, p. 339-347

### B – Books

- Gilardoni et al. 1977 Gilardoni Arturo, Riccardo Acani, Orsini Silvia Tacani, *X-Ray In Art*, Gilardoni S.p.A., Mandello Lario (Como)- Italia, 1977
- Lang, Middleton 1998 Lang, Janet, Andrew Middleton, *Radiography of Cultural Material*, Butterworth Heinemann series, Oxford, 1998
- Vlad, Niculescu 2013 Vlad, Ana Maria, Niculescu Gheorghe, *Metode instrumentale de analiză în artă și arheologie*, Performantica, Iași, 2013



### LIST OF ILLUSTRATIONS

1. *Crucifixion*. Assembly before restoration
2. *Crucifixion*. Digital radiographic images
3. *Trinity. Christ with Three Faces*. Assembly before restoration
4. *Trinity. Christ with Three Faces*. Digital radiographic images
5. *Jesus Pantocrator surrounded by The Apostles*. Ioan din Beriu Painter. Assembly before restoration
6. *Jesus Pantocrator surrounded by The Apostles*. Ioan din Beriu Painter. Digital radiographic images
7. *Madonna with Child*. Assembly before restoration
8. *Madonna with Child*. Digital radiographic images
9. *Madonna with Child*. Assembly after restoration
10. *Madonna with Child*. Detail before restoration
11. *Madonna with Child*. Detail of digital radiographic images
12. *Madonna with Child*. Detail after removal subsequent interventions
13. *Madonna with Child*. Detail after removal subsequent interventions

### LISTA ILUSTRĂȚILOR

1. *Răstignirea*. Ansamblu înainte de restaurare
2. *Răstignirea*. Imagine RX digitală
3. *Sfânta Troiță într-un trup*. Imagine de ansamblu înainte de restaurare
4. *Sfânta Troiță într-un trup*. Imagine RX digitală
5. *Iisus Pantocrator, înconjurat de Apostoli*- Zugravul Ioan din Beriu. Imagine de ansamblu înainte de restaurare
6. *Iisus Pantocrator, înconjurat de Apostoli*. Imagine RX de ansamblu
7. *Maica Domnului cu Pruncul*. Ansamblu înainte de restaurare
8. *Maica Domnului cu Pruncul*. Imagine RX digitală
9. *Maica Domnului cu Pruncul*. Ansamblu după restaurare
10. *Maica Domnului cu Pruncul*. Detaliu înainte de restaurare
11. *Maica Domnului cu Pruncul*. Detaliu imagine RX digitală
12. *Maica Domnului cu Pruncul*. Detaliu după îndepărtarea intervenției ulterioare
13. *Maica Domnului cu Pruncul*. Detaliu după îndepărtarea intervenției ulterioare



1. *Crucifixion*. Assembly before restoration

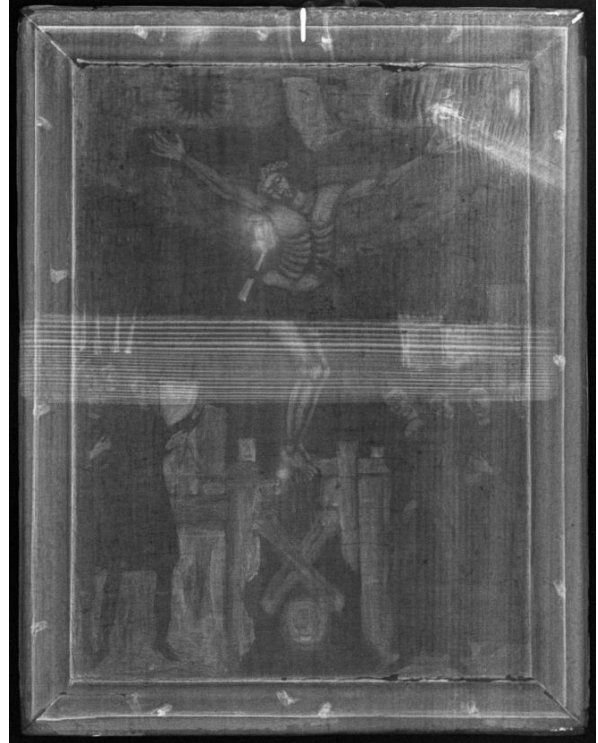

2. *Crucifixion*. Digital radiographic images



3. *Trinity. Christ with Three Faces*. Assembly before restoration



4. *Trinity. Christ with Three Faces*. Digital radiographic images



5. *Jesus Pantocrator surrounded by The Apostles*. Ioan din Beriu Painter. Assembly before restoration  
6. *Jesus Pantocrator surrounded by The Apostles*. Ioan din Beriu Painter. Digital radiographic images

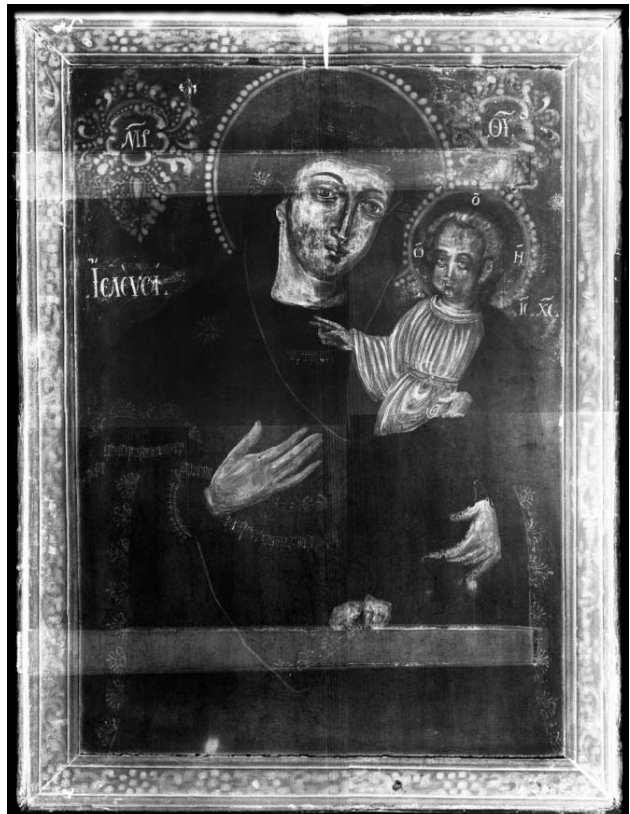

7. *Madonna with Child*. Assembly before restoration  
8. *Madonna with Child*. Digital radiographic images



9. *Madonna with Child*. Assembly after restoration



10. *Madonna with Child*. Detail before restoration



11. *Madonna with Child*. Detail of digital radiographic images



12. *Madonna with Child*. Detail after removal subsequent interventions



13. *Madonna with Child*. Detail after removal subsequent interventions



**PORTABLE XRF APPLIED TO ICONS ON WOOD.  
CASE STUDY OF FIVE ICONS FROM CLUJ METROPOLITAN MUSEUM\***

Saveta-Florica POP PhD\*\*, Márta Júlia GUTTMANN PhD\*\*\*, Iulia-Maria PASCU\*\*\*\*

**Abstract:** Portable (handheld) X-ray fluorescence (PXRF) is a non/invasive and non-destructive analytical technique that provides data in a short time regarding the elemental chemical composition of materials. The five icons from the Cluj Metropolitan Museum, on which the investigations were conducted, are painted by artists from Transylvania. One icon is dated 1673, the others belong to the eighteenth century. The results are valuable both in terms of assessing the painting materials used, and from the perspective of conservation. Silver leaf, identified in three of the five icons, reflects not just the manner of technical execution but an economic issue too. In literature, studies on the material composition of the Transylvanian icons are restricted to a few publications, making it difficult to analyse the relationships between painters of the same period, to establish the methodology and painting technique, to analyse economic or symbolic factors, the lack of information about these is setting limits in understanding the European influences.

**Keywords:** Portable (handheld) X-ray fluorescence (PXRF), icon, Cluj Metropolitan Museum

**Rezumat:** Investigațiile XRF aplicate icoanelor pe lemn constituie o tehnică nedistructivă și neinvazivă de analiză care furnizează date, într-un timp redus, cu privire la compoziția chimică elementală a materialelor. Cele cinci icoane din Muzeul Mitropoliei Clujului pe care s-au realizat investigațiile sunt pictate de artiști din Transilvania, una dintre acestea este datată în 1673, celelalte aparțin secolului al XVIII-lea. Rezultatele obținute sunt prețioase atât din prisma stabilirii materialelor folosite, cât și din perspectiva conservării și restaurării pieselor. Foița metalică din argint, identificată pe trei din cele cinci icoane, reflectă nu doar o manieră în tehnica de execuție ci un aspect de natură economică. În literatura de specialitate, studiile privind compoziția materialelor la icoanele din Transilvania se restrâng la câteva publicații, ceea ce face dificil analiza unor relații între pictorii epocii, stabilirea metodologiei și a tehnicii de execuție, precum și analiza factorului de natură economică sau simbolică. Lipsa investigațiilor la icoanele din Transilvania ne limitează și în stabilirea influențelor venite din spațiul european.

**Cuvinte-cheie:** Investigațiile XRF, icoană, Muzeul Mitropoliei Clujului

PXRF (portable or handheld X-ray fluorescence) investigations were applied to five icons on wood preserved in the collection of the Metropolitan Museum of Cluj-Napoca. The icons were made in the XVII-XVIII century by painters who claim artistic training in Transylvanian workshops, only

one of them, Priest Luca from Iclod (Cluj County), seems to be tributary to the painting style and iconographic patterns found in Polish-Lithuanian space (For the biography of Priest Luca from Iclod see Dumitran 2014).

PXRF is a widely used non-destructive technique

---

\*This work was possible due to the financial support of the Sectorial Operational Program for Human Resources Development 2007-2013, co-financed by the European Social Fund, under the project number POSDRU/159/1.5/S/132400 with the title „Young successful researchers – professional development in an international and interdisciplinary environment”.

\*\* The Mitropoly of Cluj, Maramureș and Sălaj; Email: pop.saveta@yahoo.com

\*\*\* National History Museum of Transylvania, Cluj-Napoca, “Lucian Blaga” University in Sibiu, Faculty of Social and Human Sciences; Email: guttmannmarta@gmail.com

\*\*\*\* National Brukenthal Museum; Email: iulia\_m\_pascu@yahoo.co.uk

for the measurement of the elemental chemical composition of materials (Stuard 2007, 234-238). Investigations were carried out with tube-based S1 Titan handheld XRF analyser that has the capability to qualify and quantify nearly any element from Magnesium to Uranium.

The application of PXRF to the study of icons provides valuable information for the researchers and conservators to:

- get an idea of the nature of the materials and to determine their presumed sources;
- have an idea for some of the painting materials used for the wooden icons;
- assess of the conservation state of the icon, the decay processes due to chemical, physical and biological factors;
- characterize some painting materials of a certain period of time with the possibility of establishing professional relationships between the same painters using identic methods and materials;
- identify repaintings;
- verify the authenticity of the icon;
- choose the appropriate materials and methods for conservation treatments;
- create a database of the identified materials that will enable comparative analysis of similar items, also from different European regions.

The aim of the PXRF analyses was to gather information regarding the ground layer, the metal leaf and the pigments<sup>1</sup>.

In the following, the studied icons are going to be described in chronological order, together with the information gathered by PXRF (the filler of the ground layer, the metal foil and the pigments were assessed based on the elemental analysis provided by the PXRF measurements):

1. The first of five artworks, the icon of the *Virgin with Child*<sup>2</sup> (Fig. 1) illustrates the iconographic

<sup>1</sup> PXRF investigations were carried out through the generosity of *Total Spectrum* team from Bucharest, involving Cecilia Merticaru and Lucian Mânduc, with courtesy of Claudiu Tănăsalia of the Research Institute for Analytical Instrumentation, Cluj-Napoca, to whom the authors give thanks. The interpretations of the results were made by senior conservation scientist Márta Júlia Guttmann.

<sup>2</sup> Provenience: Ilișua (Bistrița-Năsăud county), dimensions: 81,5x65 cm, without inventory number.

type of *Virgin Eleusa*<sup>3</sup>. It is painted in 1673 by Priest Luca from Iclod and it is known because of tears shed in 1717 and 1729. The event of the weeping icon is recorded and the documents are preserved in the National Archives in Cluj-Napoca<sup>4</sup>. The Slavic inscription at the bottom of the icon records the donors: *God's Servant Matei his wife Ana and children Griga, Ștefan, Ioana made this icon and gave it to the church of St. John in the village Elișoa. Year of Our Lord 1673 month February*<sup>5</sup>.

In this icon, based on PXRF investigations it was assessed that the ground layer has gypsum and gold leaf is applied over a coloured bolus. The determined elemental composition point to the following pigments: lead white, cinnabar, ultramarine blue, green and brown earth (Table I). It is the only icon from the five investigated ones where gold leaf and green earth are assumed.

2. The icon *Virgin with Child*<sup>6</sup> (Fig. 2), *Hodighitria Virgin* iconographic type, still keeps the painter name, Tudor. Could be assigned at the beginning of the eighteenth century. In the rectangular lower zone on the white background, the inscription of donation says: *This holly and divine icon was mad by Ionașco Boca with his wife Anuța to be in theirs and their sons' forever memory. Luca. Parasca*<sup>7</sup>. *Painter Tudor*. The Painter's artistic style is characterized by an accentuated design; the line is the artistic language denoting a strong expressiveness. The flat chromatic touches applied supplements the drawing.

<sup>3</sup> Egon Sendler could not decide whether there was an original iconography for this type of icon or we should see it only as a variant of *Virgin Hodighitria*, a more humane form, a maternal tenderness that respond better to the spiritual trends of a different era. See Sendler 2008, p. 127-148.

<sup>4</sup> (Dumitran, Hegedüs & Rus 2011 54-56, 384-396, fig. 4). The author didn't write his name on the icon, this is known from the witnesses that give testimony about the tearing of the icon.

<sup>5</sup> „*Robul lui Dumnezeu Matei și soția sa Anița și copiii lor Griga, Ștefan, Ioana au făcut această icoană și au dat-o la biserica Sfântului Ioan în satul Elișoa. Anul Domnului 1673, luna februarie*”. See Porumb 1998, 208.

<sup>6</sup> Provenience: Sângeorz-Băi (Bistrița-Năsăud county), dimensions: 82x54 cm, inventory number: 23i.

<sup>7</sup> „*Această s(fân)tă s(fân)tă (sic!) și dumnezeiască icoană au făcut Ionașco Boca denpreună cu femeia lui Anuța ca să le fie lor și feciorilor pomenire în veaci. Luca. Parasca. Tudor Zugravu*”.

The most important works from the artist's creation are signed, but he has not dated each of his paintings.

PXRF investigations have provided the following results: the ground layer has in its composition chalk; the metal leaf is made of an alloy containing both gold and silver. Results point to the following pigments: lead white, red lead (minimum), malachite and orpiment (Table I). This icon is the only one among the studied icons having a calcium carbonate based ground layer.

*Christ Pantocrator framed by the Apostles*<sup>8</sup> dated 1753, can be attributed to the painter Nechita, a highly productive artist in Transylvania since the fifth decade of the eighteenth century. It is known only one icon throughout his artistic work on which the artist left his signature (Porumb, 1998. 257-259, 359; Porumb 2003, 128, fig. 153; Efremov 2002, 139, 224, fig. 269)..

3. The stylistic features allows an easy identification of his work, only the later ones towards the end of the century, from the last period of his artistic creation, are not fully known and require a more rigorous analysis.

The ground layer of this icon is gypsum based. Silver metal leaf was applied over a layer of white bolus. The assumed pigments are: lead white, vermilion, ultramarine and orpiment (Table I). To obtain green, the painter Nechita seem to be used a mixture of orpiment with ultramarine. Due to conservation treatment<sup>9</sup>, the icon background and twisted rope retains small areas with silver leaf.

4. The *Deisis* icon<sup>10</sup> was made in the year 1784 by the painter Nistor from Feleac village (Fig. 4) located close to the city of Cluj-Napoca. The beardless young man in the icon background, around which the inscription says only *John*, is Saint John the Evangelist he is substituting the eponymous saint, John the Baptist, which usually appears represented in this theme. On the top and right frame the inscription with the names of icons'

<sup>8</sup> Provenance: Sânpaul (Cluj county), dimensions: 65x45 cm, inventory number: 11i. Icons featured in the exhibitions from Neuchâtel (1968-1969) and Turin (1970) and in several national exhibitions. See Nicolescu, 1971 47, fig. 76.

<sup>9</sup> The icon was restored in 1968 by Varvara Ionescu, in the year 2011 the icon had some surface cleaning. See Nicolescu 1997, p. 53.

<sup>10</sup> Provenance: Luna de Sus (Cluj county), dimensions: 73,5 x 55,5 cm, inventory number: 57. For the artistic creation of the painter Nistor from Feleac, see Porumb 1998, 265-267 (Pop 2016).

donors says: *This holy icon was paid by Căoaci Petre with her wife Ioană, to be commemoration also to their forefathers, at the church in Lona*<sup>11</sup>. The date and the painter name are inscribed on the open Gospel.

The Feleac village has special significance because the Moldavian prince Șefan cel Mare (Stephen the Great), erected here at the end of the XV<sup>th</sup> century a church that became the religious centre for the Orthodox Romanians in Transylvania. Subsequently, a monastery existed there, which had copyist's workshop. Painter Nechita's presence in Feleac attested by an icon dated from 1762 and similar stylistic elements captured in the works of the painter Nistor led us to the appreciation of master-apprentice relationship between the two artists (Porumb, 2003 a, 28-30).

PXRF measurements indicate the use of silver leaf and a gypsum based ground layer. The following pigments are concluded: lead white, cinnabar, ultramarine and malachite (Table I). The painting materials of the icon made by painter Nistor seem to be similar to the one identified on the icon attributed to the painter Nechita (Fig. 3). These, together with the stylistic similarities, can sustain the master-apprentice relationship of the two painters. Small differences in Nistor's icon are captured by the silver leaf that is applied directly over the gypsum ground layer and the use malachite green.

5. The unique icon *Christ Pantocrator*<sup>12</sup> (Fig. 5) may be assigned to the last two decades of the eighteenth century. The volume of the face, the colour and manner of application are specific to painter Nechita, but some simplified face detail betrays the painter's later work. The halo has no stucco decoration, twisted rope is missing and frame is made in the wood thickness. The compared PXRF investigations, between this icon and the previous one attributed to the painter Nechita (Fig. 3) support the proposed relationship of master and apprentice. The measurements revealed a gypsum based layer ground and silver leaf applied over a layer of white bolus, and the concluded pigments are the same in the two icons. For green an orpiment and ultramarine mixture was probably used. (Table I).

An overview of the PXRF investigations of the five icons from the Cluj Metropolitan Museum

<sup>11</sup> „Această icoană sfântă au plătit Căoaci Petre cu soțu sou Ioană să fie pomeană la tot neamul, la bisearecă la Lona, am(in)”.  
<sup>12</sup> Provenience: Nadășu (Cluj county), dimensions: 37,5 x 26,5 cm, inventory number: 46i.



gives us the following information: gold alloy is identified on a single icon, on three icons silver based leaf is found. Lead white is possible on all five icons, cinnabar and ultramarine on four of them; orpiment appears on three icons, malachite on two, red lead and green earth on one single icon. Four icons have gypsum based ground layer, while one has calcium carbonate based. (Table I).

The studies on icons from Transylvania in the seventeenth and eighteenth centuries about the composition of pigments, metal leaf and ground layer are disparate<sup>13</sup>. Two studies we consider to be relevant. The first of these published by Mihai Lupu is interesting from the prism of three icons dating from the seventeenth and eighteenth centuries belonging to the Transylvanian painting. On all three icons, gypsum, red ochre and gold leaf is identified, and only on one, tin. Lead white is present on two icons, orpiment on one. The blue pigments identified are indigo blue and Prussian blue.

The second study belongs to Alexander Efremov who in 2003 published the results of the analysis of 113 icons from the three Romanian Countries, icons assigned to XVI-XIX (Efremov 2002, 162-166.) centuries. Of the 15 icons that belong to the Transylvania painting, we are particularly interested in the 10 icons dating from the eighteenth century; we took into consideration the nineteenth century's icon.

The results of the 10 icons from Transylvania show that the ground layer is mainly based on gypsum; gold leaf is identified on a single icon, and silver and tin on two icons. Lead white was present in more icons; for red pigments, in addition of minium and cinnabar, red ochre has been identified. Ultramarine is missing from the published results of Alexander Efremov, the blue pigments present are azurite, indigo and Prussian blue. Among the green pigments malachite is identified on a single icon and verdigris on two. The authors' proposal to delineate the icons of the eighteenth century in Transylvania, that are created by trained painters of those made by a craftsman, would be interesting in terms of precious materials used by one and the other. But the concept has no finality, as the same author states: "The creations of the two

categories of artists are very close, sometimes" (Efremov 2002, 16). In Transylvania the icons were mostly designed to adorn churches and the commissioners had a higher economic power in the community, or the icons were unanimously donated by villagers as testified through the inscriptions of the icons. Gold leaf was frequently replaced by the silver or tin<sup>14</sup>, and the yellowish varnish film gives the icon a precious aspect. For Romanians in Transylvania substituting gold leaf was dictated by the economic situation, as the use of precious metal leaf swing pretty much the final value of the artwork<sup>15</sup>.

PXRF investigations applied to five icons in Cluj Metropolitan Museum's collection give us valuable information about some materials used in painting the icons from Transylvania in the seventeenth and eighteenth centuries. It claims, simultaneously, the proposed master and apprentice relationship between the painters Nechita and Nistor from Feleac and gives extra clues to confirm the attribution made in the case of the fifth icon to the painter Nechita. From another perspective, given the large number of painters who worked in that

<sup>14</sup> From the eighteenth century correspondence between manufacturers and merchants, or even directly with painters, we capture a little the relationship between the choice of materials and their cost. In the letter sent in 1781 by Barbu Știrbei Boyar mother, Dumitrana from Craiova to Hagi Constantin Pop merchant in Sibiu, she asks "I paint the holy church and I do not have, buy for me (...) only to be good (...), the good one ". The merchant John Pana from Brasov writes to his colleague, the same Constantin Hagi Pop from Sibiu, in February 21, 1789, after a discussion conducted with the painter Constantin from Brasov, which asked for information for a 4 large icons. The painter has proposed a price of 200 florins, "as we need much thoughtfulness" though, he can work with 100 florins, "but ordinary thing does not last long". The painter had well-known the chemical instability of metal leaf if it wasn't gold, especially the tin leaf and the less precious materials. The cost of these halved the cost of the icons. See Meteș, 1929 71-72, 123-125

<sup>15</sup> In the study published by Cristina Serendan, in which she followed the technical particularities of the polypych altarpiece from Dupuș; made in Transylvania around 1480 where were found four types of metal leaf: pure gold, silver, so called *Zwischgold* and tin. The conclusion regarding the distribution of them in the artwork is not based only on arguments of economic but also symbolic nature. A variety of metal leaf had to circulate in Transylvania in the seventeenth and eighteenth centuries in which the commissioners and painters chose, as we see in the previous note, the quality. See Serendan, 2014, 99.

<sup>13</sup> Márta Júlia Guttmann made the first research related to organic components of the paint layer of objects heritage in Romania. The samples analyzed were from 38 different icons on glass painting centers in Transylvania, most of the icons being framed in the nineteenth century. For these analyzes, see Guttmann 2012, Scientific Adviser: Prof. Dr. Luminița Silaghi-Dumitrescu

period, over 300 artists, from which is preserved a rich heritage, the present study constitutes a minor contribution to the knowledge regarding the icons' intrinsic elements. In order to obtain objective re-

sults the PXRF investigations should be validated by other laboratory analyses applied to the five icons, thus, ensuring, as far as possible, the impartiality of the results.

## REFERENCES

- Dumitran 2014 Anna Dumitran *Luca din Iclod, un pictor transilvănean din secolul al XVII-lea*. Available from: [http://www.academia.edu/4370625/Luca\\_din\\_Iclod\\_un\\_pictor\\_transilvanean\\_din\\_secolul\\_al\\_XVII-lea.\\_Zilele\\_Academice\\_Clujene\\_Cluj-Napoca\\_iunie\\_2014](http://www.academia.edu/4370625/Luca_din_Iclod_un_pictor_transilvanean_din_secolul_al_XVII-lea._Zilele_Academice_Clujene_Cluj-Napoca_iunie_2014) [ 14.11.2015]
- Dumitran, Hegedűs & Rus 2011 Ana Dumitran, Hegedűs Enikő, Vasile Rus, *Fecioarele înlăcrimate ale Transilvaniei. Preliminarii la o istorie ilustrată a toleranței religioase*, Editura Altip, Alba Iulia, 2011
- Efremov 2002 Alexandru Efremov, *Icoane vechi românești*, Editura Meridiane, București, 2002
- Guttmann 2012 Márta Júlia Guttmann, *Contributions to the study of organic materials in painted surfaces*, PhD Thesis Summary. Available from: [http://doctorat.ubbcluj.ro/sustinerea\\_publica/rezumat/2012/chimie/Guttmann%20Marta\\_Julia\\_En.pdf](http://doctorat.ubbcluj.ro/sustinerea_publica/rezumat/2012/chimie/Guttmann%20Marta_Julia_En.pdf). [14.11.2015]
- Meteș 1929 Ștefan Meteș, *Zugravii bisericilor române, în Anuarul Comisiunii Monumentelor Istorice. Secția pentru Transilvania*, Cluj, 1929
- Nicolescu 1971 Corina Nicolescu, *Icoane vechi românești*, Editura Meridiane, București, 1971
- Pop 2016 Saveta-Florica Pop, *Painter Nistor from Feleac in the Collections of the Metropolitan Museum of Cluj*, Revista Transilvania, no. 2, Sibiu, 2016
- Porumb 1998 Marius Porumb, *Dicționar de pictură veche românească din Transilvania. Sec. XIII-XVIII*, Editura Academiei Române, București, 1998
- Porumb 2003 Marius Porumb *Un veac de pictura romaneasca din Transilvania - Sec.XVIII*, Editura Meridiane, București, 2003
- Porumb 2003 a Marius Porumb, *Biserica arhiepiscopală din Feleac. Ciitoria lui Ștefan cel Mare*, Editura Renașterea, Cluj-Napoca, 2003
- Sendler 2008 Egon Sendler, *Icoanele bizantine ale Maicii Domnului*, Ed. Sofia, București, 2008.
- Serendan 2014 Cristina Serendan, *Corpusul altarului poliptic din Dupuș – o analiză a particularităților tehnice*, în *Ars Transsilvaniae*, XXIV, Editura Academiei Române, 2014
- Stuard 2007 Barbara H. Stuart, *Analytical Techniques in Materials Conservation*, Wiley & sons Ltd. West Sussex, 2007 p. 234-238

### LIST OF ILLUSTRATION

1. *Virgin with Child*, Priest Luca from Iclod, 1673
2. *Virgin with Child*, Painter Tudor, 1700-1720
3. *Christ Pantocrator framed by the Apostles*, Painter Nechita (attribution) 1753
4. *Deisis*, Painter Nistor from Feleac, 1784
5. *Deisis*, Painter Nechita (attribution), 1780-1800

Table I. The results of PXRF investigations applied to the five studied icons

Note: To the photographic documentation of objects contributed Saveta-Florica Pop

### LISTA ILUSTRĂȚILOR

1. *Maica Domnului cu Pruncul*, Popa Luca din Iclod, 1673
2. *Maica Domnului cu Pruncul*, Tudor Zugravul, 1700-1720
3. *Iisus Pantocrator încadrat de apostoli*, Nechita Zugravul (atribuire) 1753
4. *Deisis*, Nistor Zugravul din Feleac, 1784
5. *Deisis*, Nechita Zugravul (atribuire), 1780-1800

Table I. Rezultatele investigațiilor XRF aplicate pe cele cinci icoane studiate

Nota: la realizarea documentației fotografice a obiectelor a contribuit Saveta-Florica Pop



1. *Virgin with Child*,  
Priest Luca from Iclod, 1673



2. *Virgin with Child*,  
Painter Tudor, 1700-1720



3. *Christ Pantocrator framed by the Apostles*,  
Painter Nechita (attribution), 1753



4. *Deisis*, Painter Nistor from Feleac, 1784



5. *Deisis*, Painter Nechita (attribution), 1780-1800

1	2	3	4	5	Materials
<input type="checkbox"/>		<input type="checkbox"/>	<input type="checkbox"/>	<input type="checkbox"/>	<b>Gypsum</b>
	<input type="checkbox"/>				<b>Chalk</b>
<input type="checkbox"/>	<input type="checkbox"/>	<input type="checkbox"/>	<input type="checkbox"/>	<input type="checkbox"/>	<b>Lead White</b>
	<input type="checkbox"/>				<b>Red lead (minium)</b>
<input type="checkbox"/>		<input type="checkbox"/>	<input type="checkbox"/>	<input type="checkbox"/>	<b>Cinnabar</b>
<input type="checkbox"/>		<input type="checkbox"/>	<input type="checkbox"/>	<input type="checkbox"/>	<b>Ultramarine</b>
	<input type="checkbox"/>		<input type="checkbox"/>		<b>Malachite</b>
<input type="checkbox"/>					<b>Green Earth</b>
<input type="checkbox"/>					<b>Brown</b>
	<input type="checkbox"/>	<input type="checkbox"/>		<input type="checkbox"/>	<b>Orpiment</b>
<input type="checkbox"/>	<input type="checkbox"/>				<b>Gold</b>
	<input type="checkbox"/>	<input type="checkbox"/>	<input type="checkbox"/>	<input type="checkbox"/>	<b>Silver</b>
<input type="checkbox"/>		<input type="checkbox"/>		<input type="checkbox"/>	<b>Clay + White clay</b>

Table I. The results of PXRF investigations applied to the five studied icons



## 8 DAY CRYSTAL BALL DESK CLOCK

Florian PREDA \*

**Abstract:** *During time, watches have exceeded their technological attribution, reaching artistic dimensions. Thus, at the beginning of the 20th century, Omega designed a crystal ball clock, with two half spheres, polished and transparent, for a magnifying glass effect, making it easy to read. Although, the watch was in poor preservation state, various restoration techniques have been joined together in a common effort. And when factory parts were missing, like the half sphere, or the pendant ring, they were manufactured. The clock restoration ensures the very existence of this clock style, little known to the world.*

**Keywords:** *watch restoration, crystal ball clock, 8 day clock*

**Rezumat:** *De-a lungul timpului, piesele de orologerie si-au deparșit atribuțiile tehnologice atingând dimensiuni artistice. Asa se face ca, la inceputul secolului XX, Omega proiecteaza un ceas de masa tip sfera, cu doua calote lustruite si transparente, ce asigurau un efect de lupa, facandu-l usor de observat. Desi, ceasul se prezenta intr-o stare modesta de conservare, pentru realizarea acestui proiect, au fost reunite, intr-un efort comun, diferite tehnici de restaurare. Iar atunci cand elemente originale au lipsit, acestea au fost executate manual. Readucere la viata garanteaza insasi existenta acestui stil de ceas, foarte putin cunoscut in lume.*

**Cuvinte cheie:** *restaurare, ceas sfera, ceas cu mers la 8 zile*

**Manufacture:** Omega Watch Company

**Date:** ca. 1902

**Execution technique:** casting, molding, pressing, gilding, silvering, cutting, incising, painting, finishing, hardening, lathing, assembling, adjusting

**Size: diameter** ~9,9 cm, height including crown tube and pendant ~14,4 mm

**Conservation status:**

Desk crystal ball clock, made of nickel and mineral crystal attributed to Omega Watch Company (Richon 2007, 438), with a round case shape and a total diameter of 99 mm. The frost silver dial has a round and flat shape, and a recessed seconds dial. The Arabic numerals and the pearled minutes track are incised and blue painted. The "Pear" hands set, including the spear style seconds hand are made of heat blued steel. The movement is affixed to a nickel basin case, showing a stepped rim, to which the metal bezels of the two glass half spheres are pressed in. The movement has been manufactured by Omega Watch Company. It is wound through the crown

and set via the pin setting mechanism. Dial is covered by a bezel and a thick glass in the form of a half sphere, offering a magnifying glass effect. Face crystal has been altered showing in depth chips. The frame and the case shows various nicks, scuffs and age related marks. A similar face bezel is also present to the back, offering a magnified back view with a glass installed. Due to improper handling, the clock must have fallen from a relevant height, making the crystal break, the movement stop and the case deform at impact. Probably at the same time, the original clock pendant has been lost, and later replaced with an iron wire pendant, showing corrosion marks. When wound, the barrel does not transmit energy to the movement. Movement is not working and shows different stains and residues, produced either by mechanical wear, age, or iron corrosion.

**Applied restoration procedures:**

**Stage I:** Pendant replacement. A new pendant ring has been manufactured, after approximate specs

\*email: [contact@twistoftime.com](mailto:contact@twistoftime.com); <http://twistoftime.com>



have been provided on correspondence. Difficulties have been encountered during the execution of the bow because a similar all original specimen for comparison and correct measurements indicator was not available during execution. The new pendant ring was executed strictly on the basis of the approximate measurements, thus original specs were not followed on all respects. Although casing is made of nickel, the ring was lathe executed in stainless steel.

**Stage II:** With the help of a small, private glass casting workshop, two half spheres have been casted and finished. The difficulty of this stage consisted in the fact that each half sphere had a diameter of 95 mm. Fortunately, one of the two half-spheres was still attached to the watch and was used as a model.

**Stage III:** Case fixing. The bent metal surfaces and rims were first straightened up, then the case has been polished using brushes and felt wheels.

**Stage IV:** Movement disassembling. Since it remained separated a long time from its glass, serving besides the aesthetic effect, also as a dust cover, the movement has degraded to some level. Long exposure to temperature variation, resulted in movement bridges oxidation and rust deposits on steel parts.

**Stage V:** Chemical treatment. After using watch making specific cleaners<sup>1</sup> (Nelson 2011), it has been observed that the stains (oil, residues, water and rust) have affected in depth the frost gilt brass made bridges. A new chemical treatment was in order. Each affected part has been dipped individually, in Tetrachloroethylene<sup>2</sup> (Mertens 2002), then rinsed with distilled water. To totally remove the stains, a Polyethylene glycol<sup>3</sup> compound (NIIR India 2007, 130) has been applied only to the affected areas, then rinsed and finally cleaned in the ultrasonic cleaner. After the chemical treatment, a luster difference between treated and untreated areas has been observed. Lubrication and movement assembly

was taken care by Hermann Filker. All mechanical parts, including the original blued steel mainspring have been recovered, preserving the original manufacturing condition.

**Stage VI:** Encasing and adjusting the clock. Before fitting the movement, the case has received a final cleaning using regular horology surfactants and all residues have been removed. Approximate production date was possible using the movement serial number found under dial plate, retrieved after total dismantling. After servicing, the mainspring completely wound up around its arbor, provided a 8 day power reserve.

---

<sup>1</sup> Cleaning solution Elma WF Pro Watch Cleaner, 5 minutes, Elma Rinse solution Suprol Watch Rinse, 2 cycles, 5 minutes each, Dry in hot air chamber, 5 minutes

<sup>2</sup> Emex CM Cleaner, solvent immersion, 30 minutes, room temperature

<sup>3</sup> Displex Polyethylene wax polishing paste

## REFERENCES

- Richon 2007      Richon , *A Journey Through Time* Specialities, Small clocks, desk clocks and portfolio clocks, Omega Crystal Ball
- Nelson 2011      Nelson, Clock Cleaning Solution <http://www.snclocks.com/TechnicalInformation/Tid-Bits/Clock-Cleaning-Solution/>
- NIIR India 2007      The Complete Technology Book on Wax and Polishes
- Mertens 2002      Mertens, Cleaning metal parts, Perchloroethylene suitable for degreasing variety of metals <http://www.thefabricator.com/article/finishing/cleaning-metal-parts>

## LIST OF ILLUSTRATIONS

1. 8 day Crystal ball desk clock before restoration
2. Crystal ball desk clock side view
3. Movement view, non working condition
4. Movement plate view, before restoration
5. Side case view, movement crystal missing
6. Pendant ring sketch
7. New lathe made pendant ring
8. Half spheres casted, finished, beveled and mounted into the metal frame
9. Chemical treatment
10. Chemical treatment
11. Barrel after cleaning
12. Balance cock after cleaning
13. Train bridge after cleaning
14. Barrel bridge after cleaning
15. Movement parts after cleaning
16. Movement parts assembled after cleaning
17. Movement assembled, before and after cleaning
18. Movement and dial mounted into case, without crystals
19. Movement view after cleaning, without crystal
20. Dial view after mounting into case, without crystal
21. Dial view with bezel crystal installed
22. Side view with crystals installed
23. Side view
24. Movement view with crystal installed
25. Face view

## LISTA ILUSTRĂȚILOR

1. Ceas de birou tip sfera cu mers la 8 zile înainte de restaurare
2. Ceas de birou tip sfera, vedere laterala
3. Vedere catre mecanism, defect
4. Platina, înainte de restaurare
5. Vedere laterala, calota mecanismului lipsa
6. Schita inelului de prindere
7. Noul inel executat prin strunjire si indoire
8. Calotele turnate, finisate, fatetate si montate in ramele de metal
9. Tratament chimic
10. Tratament chimic
11. Caseta arc înainte de curatare
12. Puntea balans înainte de curatare
13. Podul trenului rotilor înainte de curatare
14. Caseta arc dupa restaurare
15. Piesele mecanismului dupa curatare
16. Ebosa asamblata dupa curatare
17. Mecanismul asamblat, înainte si dupa curatare
18. Mecanismul si cadranul montate in carcasa, fara calote
19. Mecanismul montat in carcasa, dupa curatare, fara calota
20. Vederea cadranelui, montat in carcasa, fara calota
21. Vedere cadranelui, prin calota
22. Vedere laterala cu calotele montate
23. Vedere laterala
24. Vederea mecanismului prin calota
26. Vedere din fata



1. crystal ball desk clock before restoration



2. crystal ball desk clock side view



3. movement view, non working condition



4. movement plate view, before restoration



5. side case view, movement crystal missing

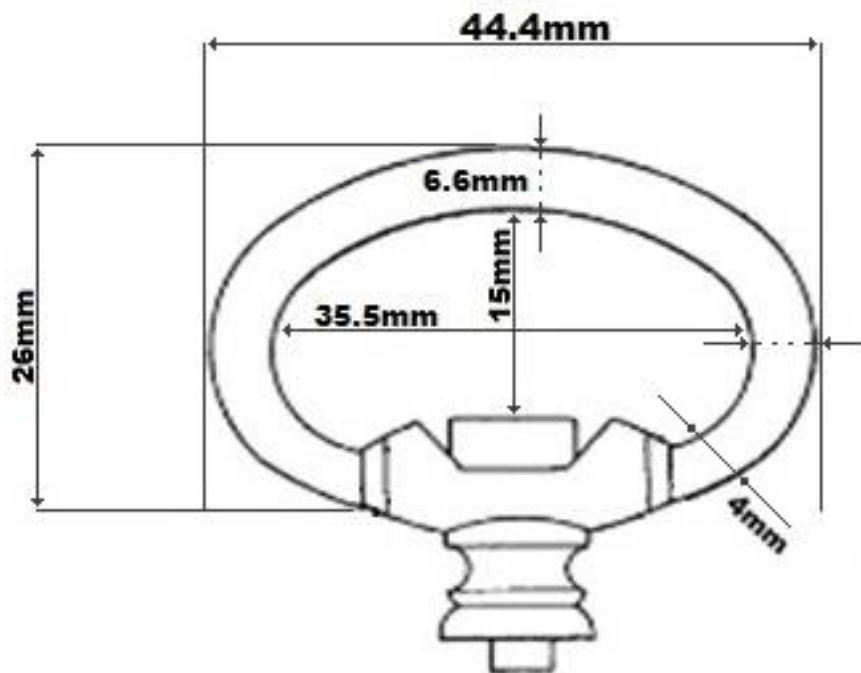

6. pendant ring sketch



7. new lathe made pendant ring



8. half spheres casted, finished, beveled and mounted into the metal frames



9. chemical treatment



10. chemical treatment

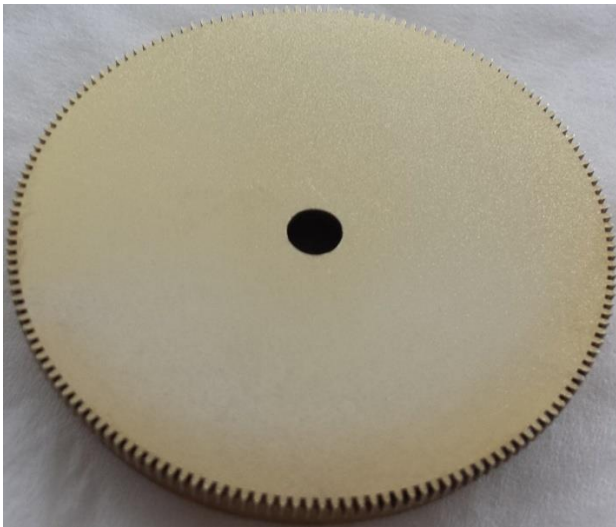

11. barrel after cleaning



12. balance cock after cleaning



13. train bridge after cleaning



14. barrel bridge after cleaning





15. movement parts after cleaning

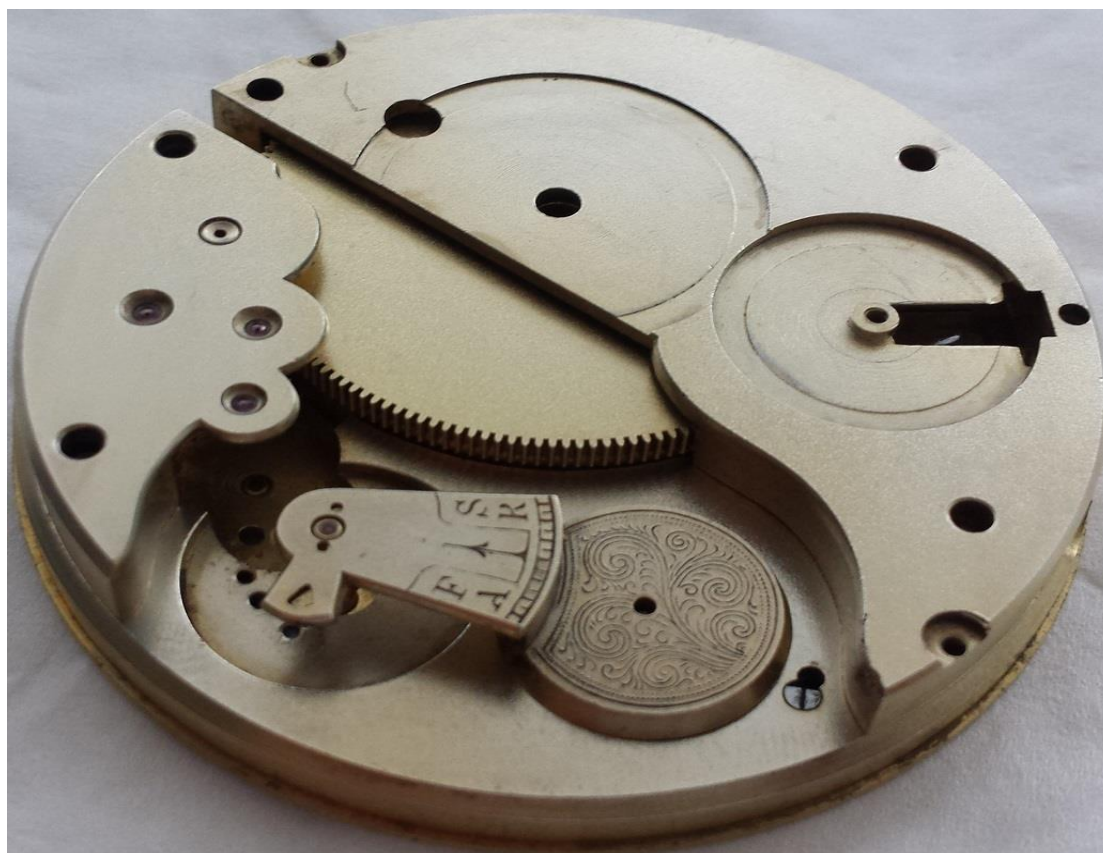

16. movement parts assembled after cleaning

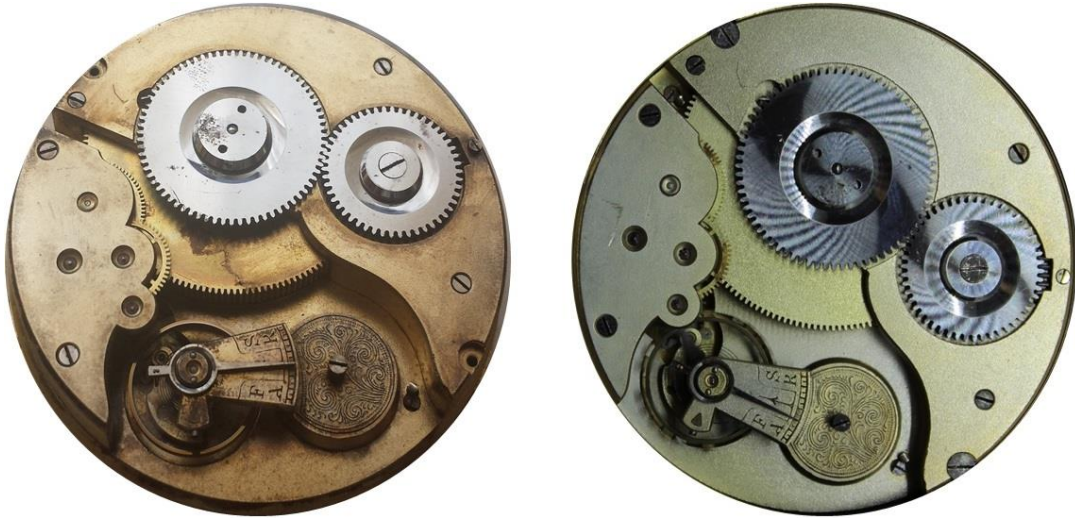

17. movement assembled, before and after cleaning



18. movement and dial mounted into case, without crystals



19. movement view after cleaning, without crystal



20. dial view after mounting into case, without crystal



21. dial view with bezel crystal installed



22. side view with crystals installed



23. side view



24. movement view with crystal installed



25. face view atment

## THE RESTORATION OF A FREEMASON SWORD

Călin BOBIC\*

**Abstract:** *The freemason sword is part of the collection of The History Museum - the Altemberger House and it represents an important element of the Brukenthal Museum Complex Heritage. Through its' composition and age provides information about the evolution of weapons types used, throughout the history, in Transylvania and Central Europe.*

**Keywords:** *restoration, metal, sword*

**Rezumat:** *Această piesă face parte din colecția de arme a Muzeului de Istorie, casa Altemberger și reprezintă un element important al patrimoniului complexului Muzeal Brukenthal din Sibiu care prin componența și vechimea sa ofera informații cruciale despre armele folosite și evoluția lor în Transilvania și Centrul Europei, printre ele numărându-se și săbiile de francmason.*

**Cuvinte cheie:** *restaurare, metal, sabie*

### Introduction

Freemason ceremonial sword is part of the Altemberger House-History Museum weapon collection, dated nineteenth century. The sword was made from a Transylvanian workshop in the nineteenth century (Nițoi 2007, 60) and later, in the year 1917, was donated to the museum by Franz von Szalay.

### Description

The Freemason ceremonial sword consists of a straight blade, with edges on both sides, that narrows gradually toward the pointed tip. Is made of steel, forged, with a length of 94 cm with tang included, the width is 2 - 1,5 cm.

The hilt, length 11 cm, is made of wood that completely enclose the tang of the sword, is wrapped in leather over which brass wire is twisted in spiral shape. The pommel is spherical and is made of brass. The guard is straight arrow-shaped with splay ends and split in the middle.

### Conservation status

The sword presents itself in a satisfactory conservation status, showing discontinuous and

uneven surface deposition of corrosion products specific to iron on the blade and copper on the brass elements. Dust and dirt clogs the entire surface. In conclusion after analysing these aspects, the necessary conservation and restoration operations were applied.

### Restoration and Conservation of the Object

Before restoration, the object was disassembled into the component parts: blade with tang; hilt, guard and brass pommel.

The treatments applied are differentiated by the composition of the components, iron or brass.

Blade treatment:

- Cleaning with nonionic detergent Romopal OF-10 in concentration of 1%;
- Drying, degreasing with acetone;
- Mechanical cleaning with flapper wheel to remove corrosion products adhering to the surface of the blade;
- Final polish with steel wool;
- Degreasing with alcohol acetone;
- Final coating with Balistol to optimal

\* Brukenthal National Museum, Sibiu

preservation (White 1995, 5);

Tretments applyed on the brass elemetents:

- Cleaning with nonionic detergent Romopal OF-10 in 1% concentration;
- Cleaning was made with phosphoric acid solution of 10% concentration, combined with intermediate brush strokes under running water until the complete disappearance of corrosion products existing on the surface of the objects (Stambolov 1985);

- Neutralization in distilled water and drying in ethyl alcohol of analytical grade;

The final operation is to assemble the object.

### **Conclusion**

Restoration of a weapon follows a technological flow set after the evaluation of conservation status and the specific characteristics of the respective piece, strictly respecting the order of tratments and the proper use of chemicals involved in the restoration process.

## REFERENCES

- Nițoi 2007 Nițoi, Anca, *Arme și armuri în colecțiile Muzeului Brukenthal*, Altip, Sibiu - Alba Iulia, 2007
- Stambolov 1985 Stambolov, T., *The Corrosion and Conservation of Metallic Antiquities and Works of Arts*, Central Research Laboratory for Objects of Art and Science, Amsterdam, 1985
- White 1995 White, Philip R., 'The care and preservation of firearms' *Technical Bulletin*, no. 16, Canadian Conservation Institute, Ontario, 1995

## LIST OF ILLUSTRATIONS

1. Anseble before restoration
2. Detail blade, guard, hilt
3. Detail of the blade corosion products
4. Detail of the object disassembled into the component parts before conservation treatment
5. Detail of the object disassembled into the component parts after the conservation treatment
6. After Restoration
7. Detail after conservation treatment

## LISTA ILUSTRĂȚILOR

1. Ansamblu înainte de restaurare
2. Detaliu lama, garda, mâner
3. Detaliu distribuția produșilor de coroziune, lamă
4. Detaliu obiect dezasmblat în elementele componente, înainte de
5. Sabia dezasmblată în elementele componente
6. După restaurare sabia și teaca
7. După restaurare





1. Ansamble before restoration



2. Detail blade, guard, hilt



3. Detail of the blade corrosion products



4. Detail of the object disassembled into the component parts before conservation treatment



5. Detail of the object disassembled into the component parts after the conservation treatment



6. After Restoration



7. Detail after conservation treatment



## THE METHODOLOGY USED FOR RESTORATION OF CARVED AND GILDED ORNAMENTS FROM SAINT EKATERINA CHURCH IN BUCHAREST

Cristina Maria DĂNEASĂ\*

**Abstract:** *The case study refers to restoration of some fretted, carved and gilded ornaments from iconostasis and bishop's throne from Saint Ekaterina Church in Bucharest. The big problem of this activity was to remove the inadequate intervention of empiric restoration around 1980.*

**Keywords:** *conservation, restoration, fretted, carved and gilded ornaments, inadequate interventions, Saint Ekaterina Church*

**Rezumat:** *Studiul de caz la care se face referire în acest articol sunt o parte dintre ornamentele traforate, sculptate și poleite de la iconostasul și tronurile arhieresti din Biserica Sfânta Ecaterina, București. Cea mai deosebită provocare întâlnită pe parcursul restaurării a fost îndepărtarea intervenției inadecvate de restaurare din jurul anului 1980.*

**Cuvinte cheie:** *conservare, restaurare, ornamente traforate, sculptate și aurite, intervenții neadecvate, Biserica Sfânta Ecaterina*

### Introduction

The Saint Ekaterina Church is located at the start of Patriarhie hill, in the centre of Bucharest City. On this place was a Monastery erected during Alexandru 2<sup>th</sup> Mircea Reign (1574-1577) and finalized during his son Mihnea Turcitul Reign (1577-1583). The church and entire monastery was suffered after turkey retirement in 16<sup>th</sup> century and vandalism actions of Gabriel Bathory in 1611. Ekaterina, wife of Alexandru Ipsilanti was the person how revived the monastery. After demolition of the old church, the actual one was finished in 29 March 1850. The plan of building is trilobite with a tower on west part. The important painter was working here like Mișu Pop and Constantin Lecca. The iconostasis, pulpit and bishop's thrones are made in eclectic manner with baroque fretted carved decor covered with gold leaf. Around 1980 were restored the iconostasis and important pieces of liturgical furniture. In this article is presented the methodology of restoration of decorative wood ornaments from iconostasis and bishop's thrones. ([parohiasfantaecaterina.ro](http://parohiasfantaecaterina.ro))

### State of conservation

The restoration from '80 years was made rapidly with gold imitation and bronze. The wood missing part were partially completed but on inadequate way. The conservation condition from the church are not properly for wooden objects and the gold imitation was quickly anaesthetic deteriorated. We didn't find here an important biological attack but the variations of humidity and temperature over the year caused many modifications of wood, torsion, cracks and fractures, losing many ornaments from iconostasis and bishop's thrones (Thompson 2004, 17).

Polychrome layers suffered a lot of deteriorations because the changes of wood are more evident in fretted and carved sides and the narrow pieces are more exposed to physic deterioration. So the polychrome layers were missed on exposed areas, present cracklings, are weakened and detached from decreased support. The gold leave was damaged and layer of red bole was visible (so in this situation was made that inadequate intervention how consist in application of gold imitation).

### Conservation and restoration treatments

For the restoration of iconostasis, pulpit and tow

\* Lecturer at Lucian Blaga University from Sibiu, Faculty of Social and Human Sciences, Department of History, Heritage and Protestant Theology, Conservation and Restoration Section; email: [cristinadcm@gmail.com](mailto:cristinadcm@gmail.com)

bishop's thrones was made by a team of four with the same coordinator. In case of restoration of a part from iconostasis and one bishop's throne - fretted, carved and gilded elements - the coordinator was Diana Iuliana Barbu. The methodology was the same and here is detailed one from this ornament.

After the research of any ornaments, after the identification of fragments and missing parts, all the pieces was documented with surveying drawings and photos. From a deteriorated part was extracted a little sample for stratigraphy, because the analysis of gold leaf was made for the restoration project.

The surface was cleaned with a brush, but the fragile parts were avoided. That one was consolidated with rabbit glue. The broken wooden parts were rebounded with animal glue. In another case was necessary to use wooden nails to consolidate the entire ensemble made from wood.

On the areas where were visible polychrome losses was completed with primer and from covered parts was necessary to remove the bronze and gold imitation from lacunas.

From stratigraphy we can see that the original gold leaf was glued on bolus and after that on inadequate restoration was applied a new coloured primer, oil bounding media, imitation gold and bronze. On some ornaments we can see that upper this intervention was coloured with red some flowers.

Because the gold kept under gold imitation is very sensible to polar solvents the methodology was made on paint remover solutions. Many mixture

was tested and the better combination was used – a mixture of aliphatic hydrocarbure with amide. So it was removed with toluene, acetone and dimethylformamide and neutralized with ethanol. It was necessary to applied little compresses for ten minutes and after the removing of two layers was made mechanically with dental wax modelling knife and brushes. The primer applied during '80 years' intervention can be removed in this way. Another tests was made and the better mixtures used were: warm water and linseed oil; izopropanol, ethanol, water and ammonia. The method was the same, so the surface was softened with the solution and little brushes, after that the primer and the dirt was removed mechanically with dental wax modelling knife.

Aquarelle colours were used for the chromatic integration. The ornament was varnish with Damar resin remiss in turpentine.

### **Conclusion**

In many cases we find only gold imitation upper original gold. This intervention were made without a new primer upper original gold leaf. So in that cases to remove an old intervention are necessary hydrocarbure mixture in general. But in these cases the primer was a great provocation for our skills and patience. The process of restoration lasted unexpectedly long, but the work is sustainable because entire church – historical monument - was restored. The restoration of iconostasis was finish in December 2015 and the restoration of bishop's throne is still continuing.

## REFERENCES

Thompson 2004                      Thompson, Daniel V. Jr., *Practica picturii tempera*, Editura Sophia, București, 2004

<http://parohiasfantaecaterina.ro/>    <http://parohiasfantaecaterina.ro/istoric/>

## LIST OF ILLUSTRATIONS

1. Bishop's throne ensemble and detail with the fretted, carved and gilded ornament restored
2. Detail with deterioration of imitation of gold from inadequate interventions
3. Detail with stratigraphy upper the gold leaf
4. Tests for removing the imitation of gold and linseed oil glue
5. Tests for removing the primer from original gold
6. Detail – during removing of ulterior primer
7. The fretted, carved and gilded ornament before restoration
8. The fretted, carved and gilded ornament after restoration
9. The icon of Saint Ekaterina - detail from iconostasis after restoration (and the restored ornaments)

## LISTA ILUSTRĂȚILOR

1. Scaunul arhieresc – ansamblu și detaliu cu ornamentul traforat, sculptat și poleit
2. Detaliu cu degradarea imitației de aur de la intervențiile ulterioare, neadecvate
3. Detaliu straturile suprapuse ulterior peste foița de aur
4. Teste de îndepărtarea imitației de aur și a mixtionului pe bază de ulei de in
5. Teste de îndepărtare a preparației ulterioare de pe aurul original
6. Detali din timpul îndepărtării preparației ulterioare
7. Ornamentul traforat, sculptat și aurit – înainte de restaurare
8. Ornamentul traforat, sculptat și aurit – după de restaurare
9. Icoana Sfintei Ecaterina – detaliu din iconostas după restaurare (și ornamentele restaurate)



1. Bishop's throne ensemble and detail with the fretted, carved and gilded ornament restored

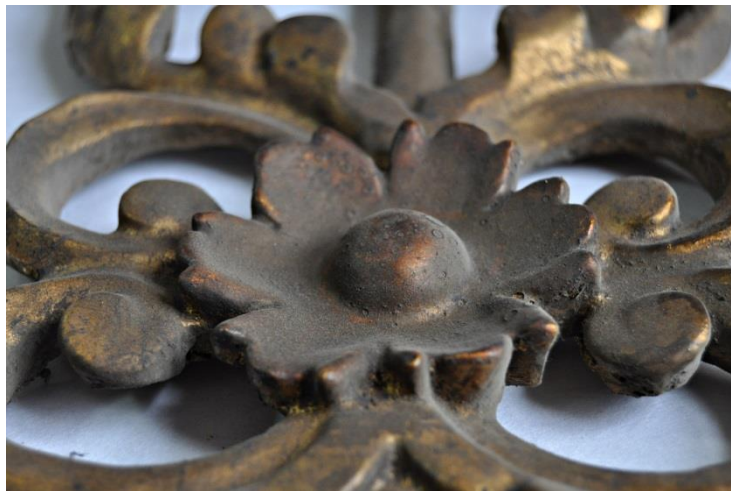

2. Detail with deterioration of imitation of gold from inadequate interventions



3. Detail with stratigraphy upper the gold leaf



4. Tests for removing the imitation of gold and linseed oil glue



5. Tests for removing the primer from original gold



6. Detail – during removing of exterior primer



7. The fretted, carved and gilded ornament before restoration



8. The fretted, carved and gilded ornament after restoration





9. The icon of Saint Ekaterina - detail from iconostasis after restoration (and the restored ornaments)

## RESTORING TWO TABLE CLOCKS FROM THE COLLECTION OF THE BRUKENTHAL NATIONAL MUSEUM

Ioan BRAI\*

**Abstract:** *There are different opinions and styles that are related to clock reconditioning and restoration. On one hand, some argue that reconditioning means bringing the clock to its original state, including its functionality which sometimes means changing some of its components with new ones which makes the object lose many of its original ones. Others such as restorers support the idea of preserving as many as the original pieces sometimes even if it is necessary to renounce the functionality of the clock, proceeding to what actually is called conservation. The conservation and the restoration interventions on the clocks were made in the Brukenthal National Museum laboratory, during which they were brought to the state where they can be displayed in the museum, without sacrificing any of the original components but adding some that made the piece complete*

**Keywords:** *pendulum, clock, mechanism, restoration, conservation*

**Rezumat :** *Sunt diverse curente și opinii legate de recondiționarea sau restaurarea ceasurilor. Pe o parte unii susțin că recondiționarea înseamnă aducerea ceasului la starea inițială inclusiv funcționalitatea acestuia, ceea ce înseamnă uneori, intervenții și schimbări ale unor componente cu altele noi, care fac ca obiectul să piardă multe din componentele sale originale. Alții, cum este în cazul restauratorilor este susținută ideea păstrării a cât mai multe din piesele originale, câteodată mergându-se până într-acolo încât să se renunțe inclusiv la funcționarea ceasului, dacă pentru a-l pune în funcțiune înseamnă renunțarea la piesele originale, trecându-se de fapt la ceea ce se numește conservare. Intervențiile de conservare și restaurare asupra ceasurilor au fost executate în cadrul laboratorului de restaurare al Muzeului Național Brukenthal, timp în care ele au fost aduse la stadiul în care acestea pot fi expuse în muzeu, fără a se renunța la nici o piesă originală dar adăugându-se componente care au făcut ca piesa să fie completă .*

**Cuvinte cheie:** *pendul, ceas, mecanism, conservare, restaurare*

The early history of mechanical clocks is uncertain and obscure. It is believed that the first mechanical clocks were invented by the Arabs as they were more advanced scientifically at that time period, and were brought to Europe by the Crusaders. In Europe, the first clocks were created by blacksmiths and locksmiths, as they were made out of iron and designed to be put on the wall or the older ones in towers because of the weights they needed to operate the mechanism, the clocks were not used in homes for telling the time, they were used in monasteries and churches in order to signal the start of church services ([istoria-măsurării-timpului.html](#)).

Italy was the first country in this domain, but later workshops appeared in southern Germany, in cities

such as Nuremberg, Augsburg, Ulm and Cassel which became more known for the timepieces created. In Italy, southern Germany and then France, the weights necessary to make the clock function, have been replaced by coiled springs. The pioneer of this invention was Peter Henlein from Nuremberg. Due to the compact mechanism and relatively small size, the clock could have beside its practical component often a fantastic side, the clock's design (Istoria-ceasului).

At first, the spring powered clocks lacked precision. When the spring was strained to the maximum, the rotational speed of the mechanism was high, then falling gradually. The pendulum was originally designed by Leonardo da Vinci during the Renaissance. He's pendulum mechanism has

---

\* Brukenthal National Museum, Sibiu; email: john30x@yahoo.com

been used for powering, saws, pumps, and bellows. Galileo used the pendulum for measuring time but the invention of the pendulum clock is attributed to Christian Huygens in 1656 (Tănase 2012).

The anchor controller, invented by Robert Hooke around 1660 has the same accuracy effect for pendulum clocks (Rațiu 1936, 23).

The first clock that was restored, is a table clock (M1036) (Fig.1), in the neoclassical style, built in a Viennese workshop and it is dated from the first half of the nineteenth century, with the dimensions: width 28 cm; 13 cm thick; height 35 cm; dial diameter 12 cm. The dial is enamelled with Arabic numerals, continued in the centre with a decorative brass plate. The pedestal and case of the clock is polished wood with shellac, mixed with black pigment. The casing is supported on 2 legs, the one in the back is hand sawed and polished with black shellac and, the other one is represented by a lyre decorated with gilded vegetal motifs. Around the base there is a decorative gold profiled frame, the alabaster statue is missing from the top of the casing.

The entire surface of the casing and the pedestal is covered with a fine layer of dust due to exposure. Previous interventions are visible at the top of the housing and at the decorative gold profiled frame (Fig.4). The mechanism is complete (Fig.3), excluding missing pendulum. It was cleaned with extraction gasoline and then greased with oil for fine mechanisms. The glass was degreased with ethylic alcohol and set in the brass frame. The brass removable parts (Fig.2) (the gong support, the dial frame, the plate from the centre of the dial) were degreased with acetone, immersed in ortho-phosphoric acid 20%, mechanically cleaned with a brass brush under running water, polished with Autosol paste and protected with special cloth named Exquisit. The dial (Fig.3) made out of enamelled copper presented a missing part at the base of number twelve, the area was degreased with ethylic alcohol then was filled with epoxy resin in which white pigment was added to bring the resin to the colour tone of the dial (Fig.7). The steel gong was cleaned mechanically with a rotating brush then passivated with BallistolR (Eco-friendly non-toxic, cleaner, lubricant, preservative for metals).(White 1995, 5)

The casing and the pedestal were dusted, sanded with fine steel wool and repolished with shellac mixed with black pigment.

The gilded parts (the lyre and decorative gold profiled frame) were cleaned with Deck 3000 a paint

remover and neutralized with white spirit (Fig. 5). The pendulum was created by imprinting in silicone a similar clock's pendulum, and after cast in Sintolit resin (a polyester resin used for bonding and filling marbles, granite and stones, with good properties of resistance and stability). After the cast was made, it was gilded and attached to a metal rod. The back case cover was made of fir the same wood as the case, finished and polished with shellac mixed with black pigment. The old screws of the mechanism casing were replaced with new brass ones (Fig. 6).

The second clock that was restored, is also a table clock (AD 434) (Fig. 9,10), in the neoclassical style, built in a Viennese workshop and is dated from the first half of the nineteenth century, with the dimensions : width 22 cm; height 31 cm; 11 cm thick; dial diameter 12 cm. The dial is enamelled with Arabic numerals, continued in the centre with a decorative brass plate. The pedestal and case of the clock is polished wood with shellac, mixed with black pigment. The case is supported in the back with a steel wire support (improvisation) (Fig. 10) and in the front by two sphinx figures with female faces, carved and gilded seated back to back (Fig. 9). The mechanism is complete with the exception of the pendulum which is missing.

The mechanism was cleaned with extraction gasoline and then greased with oil for fine mechanisms. The glass was degreased with alcohol and its frame was polished with Autosol paste, and protected with a special cloth named Exquisit. The brass removable parts (Fig. 11) (the gong support, the plate from the centre of the dial) were degreased with acetone, immersed in ortho-phosphoric acid 20%, mechanically cleaned with a brass brush under running water, polished with Autosol paste and protected with special cloth named Exquisit. The dial made out of enamelled copper, was degreased with ethylic alcohol. The deformed gong was brought to its original shape and it was cleaned mechanically with a rotating brush then passivated with BallistolR (special oil for ferrous metals) (Fig. 10). The casing and the pedestal were dusted, sanded with fine steel wool and repolished with shellac mixed with black pigment. The two sphinx figures, carved and gilded were cleaned with paint remover Deck 3000 and white spirit. The pendulum was created by imprinting in silicone, a similar clock's pendulum, and after, cast in Sintolit resin. After the cast was made, it was gilded and attached to a metal rod. The back case cover was made of fir, finished and polished with shellac mixed with black pigment (Fig. 12). The old

screws of the mechanism casing were replaced with new brass ones. A key was made for tensioning the springs; it was made out of a brass rod that was bent and drilled and also soldered (Fig.14). Instead of the wire support, in the back, it was created a new lyre-shaped support that was taken from a clock of the same type, which was gilded in gold imitation foil to have the same effect as the original gilded pieces (Fig. 13).

After restoration, the table clocks have been brought to working order; also by respecting the principles of restoration they have been completed. Currently the two pieces are displayed in the National Brukenthal Museum. (Fig. 8, 14)

## REFERENCES

- Istoria-ceasului <http://www.beclockwise.ro/istoria-ceasului> Available from: 01.08.2016, 23:45
- istoria-măsurării-timpului.html <http://geoe.weebly.com/istoria-m259sur259rii-timpului.html> Available from: 01.08.2016, 23:22
- Rațiu 1936, 23 Rațiu, Ioan, Tehnica și arta ceasornicarilor giuvaeruilor țintuitorilor gravurilor și opticienilor, Institutul de Literatură și Tipografie "Minerva" S.A. Cluj 1936
- Tănase 2012 Stelian Tănase, <http://www.stelian-tanase.ro/mica-istorie-a-ceasului/>
- White 1995, 5 White, Philip R, `The care and preservation of firearms` Technical Bulletin, no.16, Canadian Conservation Institute, Ontario, 1995

### LIST OF ILLUSTRATIONS

1. Assembly before restoration
2. Detail, disassembled before restoration
3. Detail, dial and mechanism disassembled before restoration
4. Detail, previous intervention
5. Detail, disassembled after restoration
6. Detail, added pieces to the clock; pendulum, back cover housing (verso), screws
7. Detail, dial and mechanism assembly after restoration
8. Assembly after restoration
9. Assembly before restoration (front)
10. Assembly before restoration (verso)
11. Detail, disassembled before restoration
12. Detail, case back cover made for the clock (front)
13. Detail, the new lyre-shaped support made for holding the clock's case, gilded and modeled after a clock of the same type
14. Assembly after restoration with the mechanism tensioner spring key

### LISTA ILUSTRĂȚILOR

1. Ansamblu înainte de restaurare
2. Detaliu; dezasamblat înainte de restaurare
3. Detaliu; cadran și mecanism dezasamblat înainte de restaurare
4. Detaliu; intervenție anterioară
5. Detaliu; dezasamblat după restaurare
6. Detaliu; piese confecționate și adăugate ceasului; pendul, capac pentru spatele carcasei (verso), șuruburi
7. Detaliu; cadran și mecanism asamblate după restaurare
8. Ansamblu după restaurare
9. Ansamblu înainte de restaurare (față)
10. Ansamblu înainte de restaurare (verso)
11. Detaliu; dezasamblat înainte de restaurare
12. Detaliu; capac confecționat pentru spatele carcasei ceasului (față)
13. Detaliu; piciorul de prindere al carcasei de postament, confecționat și aurit după modelul unui ceas de același tip
14. Ansamblu după restaurare împreună cu cheița de tensionare a arcurilor mecanismului



1. Assembly before restoration



2. Detail, disassembled before restoration

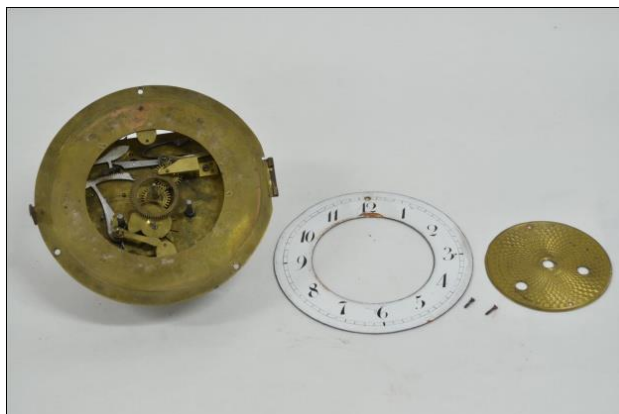

3. Detail, dial and mechanism disassembled before restoration



4. Detail, previous intervention



5. Detail, disassembled after restoration





6. Detail, added pieces to the clock; pendulum, back cover housing (verso), screws



7. Detail, dial and mechanism assembly after restoration



8. Assembly after restoration



9. Assembly before restoration (front)



10. Assembly before restoration (verso)



11. Detail, disassembled before restoration



12. Detail, case back cover made for the clock (front)

13. Detail, the new lyre-shaped support made for holding the clock's case, gilded and modeled after a clock of the same type



14. Assembly after restoration with the mechanism tensioner spring key

## RESTORATION OF THE PAINTED LAYERS ON THE LEFT ROYAL DOOR FROM THE ICONOSTASIS OF THE BIG ROYAL CHURCH IN TÂRGOVIȘTE, DÂMBOVIȚA COUNTY

Constantin SCĂRLĂTESCU\*

Cristina MIHU\*\*

**Abstract:** *The aim of this article is to inform about the importance of good environmental and storage conditions but also showing the ongoing restoration of the Royal Door belonging to The Big Royal Church iconostasis, in Târgoviște. Dealing with old restoration, restorers nowadays have to face many problems, mainly caused by the incompatibility of former materials, but also due to inaccurate aesthetic interventions like aggressive over cleaning, inappropriate overpainting and revarnishing probably done by unauthorized personnel. Due to the human factor, improper storage conditions, natural aging of materials, and delaying the restoration interventions, the degradations evolved creating irreversible losses. The focus of the treatment consisted in regaining the physical stability, uncovering and cleaning the painted layers as well as regaining its functionality and the aesthetic unity to allow the future exposition of the object.*

**Keywords:** *wood, conservation, restoration, iconostasis, royal door, repainting*

**Rezumat:** *Scopul propus de această lucrare a fost aducerea la cunoștință a importanței mediului și condițiilor de păstrare a operelor de artă, dar și prezentarea operațiunilor de restaurare, în desfășurare, asupra Ușii Împărătești aparținând iconostasului Bisericii Mari Domnești, Târgoviște. Având de-a face cu vechi restaurări, în prezent, restauratorii se confruntă cu multe probleme datorate incompatibilității materialelor folosite în trecut, în principal datorate intervențiilor inadecvate cu rol estetic precum curățiri excesive, repictări necorespunzătoare și revernisări făcute probabil de persoane neautorizate. Datorită factorului uman, condițiilor improprii de păstrare, îmbătrânirii naturale a materialelor, precum și întârzierea operațiunilor de restaurare, degradările au evoluat producând pierderi ireversibile. Scopul intervențiilor a fost redarea stabilității fizice, îndepărtarea murdăriei și curățirea straturilor picturale, dar și redarea funcționalității și unității estetice, pentru viitoarele expuneri ale obiectului.*

**Cuvinte cheie:** *lemn, conservare, restaurare, iconostas, ușă împărătească, repictare*

The paintings of the iconostasis were executed at the request of Constantin Brâncoveanu, by the Greek painter Constantios and his team, composed of Ioan, Ioachim and Stan. They were the founders of Hurezi School, and the creators of a new and unique painting style, inspired by Brâncovenesc architecture. Brâncovenesc art, is a synthesis between the Byzantine, Ottoman, late Renaissance, and Baroque style. The new trend was inclined towards a narrative style. For the first time, we have profane motifs, portrait, represented in vast galleries of votive character and historical compo-

sitions. In the Byzantine tradition, sculpture could not have any religious role, so the Byzantine canons were enriched with decorative elements that abound in ornaments framing the painted scenes. Strongly influenced by the Baroque style, the decorative elements are mainly vegetal motifs, which combine graciously with geometrical and anthropomorphic elements. The vegetal patterns are very diverse and dynamic, scrolling vines, vine leaves, grapes, acanthus leaf, winding between the boldly delineated geometric elements. Another specific element for Brâncovenesc style is the angel in the

---

\*Brukenthal National Museum, Sibiu, email: cristiart24@yahoo.com

\*\* Brukenthal National Museum, Sibiu, email: cri.mihu@yahoo.com

upper side of the door that transforms from torso in vegetal elements. The carving techniques used in decorating the royal doors is bas-relief and alto relief and in the upper part the ornaments were made by drilling them into the panel. The sculpture covers densely the whole door, but remains as an annex of painting, bounding and creating the specific richness of brâncovenesc art. The doors have painted on them an icon of the Annunciation in the form of a diptych (the Theotokos on the right door, and the Archangel Gabriel on the left). On the exterior side, are painted the prophets David and Solomon, enclosed by a wooden frame with golden geometrical elements and a column with vegetal motifs. Below them are four golden medallions, representing the Evangelists symbols: Matei and Marcu on the left door, Ioan and Luca on the right side. The wooden doors are intricately carved and gilded, and are topped by a cross. The paintings is influenced by the Byzantine style, but the new thing that this style brings is the fact that the portraits are no longer static, they are very expressive and is given a lot of attention to the physiognomy. Also, the chromatic is typical of Brâncoveanu style. The sculpted elements and the painted scenes are gilded; gold symbolizes divine presence, glory, spiritual light, creating a powerful contrast with the blue background. The icons have a sure and elegant drawing and are carefully painted with bright and vivid colors. The study of the characteristics of the brâncovenesc style to which the Royal Doors of the Big Royal Church iconostasis belong to has been realised under the coordination of Dr. Mirel Bucur, expert restorer. The Royal Door consists of two hinged doors carved in linden wood, gilded and painted (Fig.1). "Wood is a complex material. It consists of the elements carbon (C), oxygen (O), hydrogen (H), nitrogen (N) and minerals. The main constituents of wood are cellulose 40-50%, polysaccharides 15-35%, lignin 20-35%, extractives 1-3%." (Nicolaus 1998, p. 17) We do not know much about the constructive techniques of the wooden support, due to the severe damage and previous interventions. The date of these interventions, 1929, is carved on the back of the right door. The ground or the preparation layer is typical, probably made from an inert material, like calcium carbonate and a binding media, animal glue. Over this layer was applied a yellow bole, used under the metallic leaf. "The yellow bole creates warmer effects, which enhance the color of the gold, brightening the surface." (Pignolo 2000, p. 91) According to Cennino Cennini, for a higher gloss of the golden leaf, you have to burnish the bolus with "agate stone, amethyst or car-

nivores teeth" (Cennini 1997, p. 94). On the golden leaf, the sketch was made by incisions, and then painted with watercolors. After the sketch was made the painting was executed with pigments in watercolor technique. A pigment is a powder that can be main. 118) On top of them a protective layer was applied probably based on natural resins like Dammar.

Due to exposure in an inappropriate environment, natural aging of the materials and previous interventions the Royal Doors was badly damaged.

The wood had suffered structural degradation from the massive attack of *Anobium punctatum*, inactive at the moment when the door entered the restoration laboratory. The infestation occurred due to the unsuitable microclimate conditions with high humidity of the environment, diminishing the mechanical resistance. In addition the wooden material suffered significant losses, cleavages, rifts cracks and fractures on the whole surface. The main cause of this deterioration, were the inadequate previous interventions executed, on the back of the door, in 1920. The back of the door has been duplicated with panels made of linden wood, and consolidated by a metallic structure inserted in a bitumen layer. This caused numerous tensions in the wooden support and increased considerably the weight of the door. The metallic structure and the bitumen layer were removed mechanically and replaced by new and appropriate materials. After the removal of the elements, the structural consolidation was made, brushing over the surface a Paraloid B72 based solution. For the mechanical consolidation a fibreglass layer was applied over the entire surface, affixed with Devcon epoxy resin. A layer of Balsite (W+K) was used to replace the bitumen layer, on top of which were affixed the linden wood panels. These complex interventions were executed in the restoration laboratory of the Brukenthal National Museum, Sibiu by the student Ioan Brai under the coordination of expert restorers Constantin and Cristina Scărlătescu; all materials used are tested for long-term stability in the future. Painted layers were subject to mechanical stresses caused particularly by constantly changes in the relative humidity of the atmosphere. Various deterioration traces were present on the entire surface. The base layer was brittle and suffered desiccation due to inappropriate storage conditions and natural aging of the binding agent (Fig. 2). Serious cracks and cleavages of the paint layers were present all over the surface. The separation of paint from the ground layer, evolve causing blistering, flaking and massive loses. A fine network of cracks can be seen in the varnish and paint layers, caused by

several different deterioration mechanisms (Fig 3). "Probably the single most obvious sign of old age and change in paintings is craquelure. It is apparent in all older pictures and influences their appearance to a greater or lesser extent. This network of fine cracks is dependent on the materials used for the painting, the painting technique of the artist, the atmospheric conditions the painting has been exposed to, and the way in which it has been treated." (Nicolaus 1998, p. 165) As an attempt to renew and embellish the Royal Doors, the whole blue paint was fully over painted, modifying and altering the original aesthetic image. The new layer applied became more compact than the original colour layer. This inaccurate over painting layer, occupying most of the door surface, could not be chemically identified, was insoluble and had a glass-like texture. Also a new paint layer was added on top of the painted scenes, in the course of earlier interventions, in order to hide the degradations and to integrate the missing areas. This over painting was badly made with unsuitable materials, overlapping the lacuna. It disrupts the aesthetic integrity of the scene and doesn't have a historical value. "It can be carried out for numerous reasons such as to change the artwork's historical and cultural meaning or to follow stylistic trends. It can also be done after a failed intervention or following deterioration. Generally, the use of this term is derogatory because it can imply historical forgery, since it does not meet modern criteria of respect for the original and readability of the intervention. In other cases, and if it can be chronologically dated, it can become an intrinsic part of the artwork." (EwaGlos 2015, p. 176)

The Royal Doors were badly damaged due to inappropriate handling, daily-wear, „maintenance” and over cleaning with aggressive cleaning products by unauthorized personnel. This caused the increased wear of the metallic leaf and severe losses of the painted layers. The door, repaired on numerous occasions earlier, was covered by a thick layer of varnish which had turned brown, obscuring the pictures true and vivid colours. Also local varnish losses and congestions due to inadequate re-varnishing process were present on the entire surface (Fig. 4). These inaccurate interventions done for hygiene issues or the need to refresh the images were incompatible, and led to additional and accelerated deterioration of original materials. The true degradation state couldn't be evaluated exactly due to excessive dirt accumulated in time. Extraneous materials including atmospheric particles, dust, dirt, accreted materials, wax deposits

and bitumen layers from previous interventions were present on the entire surface.

After a thorough investigation and documentation of the Royal Doors, regarding the original form, materials and state of conservation, but also historic, artistic and scientific investigations, we could elaborate the restoration concept and methodology. The restoration treatment started with the removal of superficial grime and surface dust, with a brush, scalpel and a low vacuum suction.

After that, the facing was made by applying a layer of Japanese veil with worm skin glue, with a 3-6% concentration. This had the role to protect the damaged painting layers during structural and mechanical consolidation of the wooden structure.

The next step was the levelling of the wooden elements used previously at the consolidation on the back of the door, with chisels and scalpels.

Stabilisation and repairing the wooden support involved treatments which allowed the object to be safely handled and moved and facilitated further conservation treatments.

The structural consolidation implied brushing and injecting the weakened wooden parts with Paraloid B72, an acrylic resin, dissolved in ethyl acetate ( $\text{CH}_3\text{COOC}_2\text{H}_5$ ) with a gradual concentration of 6-12%. „Acrylic resins are created by the polymerization of acrylic acids and their esters.” (Nicolaus 1998, p. 232) The extensive networks of tunnels bored by insects create an effective system for distributing the consolidator. The capillary effect created draws the consolidator deep into the support.

For mechanical consolidation, different methods were implied, according to the type and extent of the damage. The small wooden losses, cracks and the missing sculpted elements were made with putties from Balsite. The cracks and other small wooden losses were filled with the spatula. The missing sculpted elements were made by analogy with the other door by taking silicone rubber moulds and casting Balsite in them. These elements were affixed with Devcon epoxy resin. On the edges, the large gaps of wooden materials were filled in with wooden lime inserts affixed with the help of bone glue and wooden dowels. Afterwards the new elements were levelled with sandpaper and chisels.

This was followed by the reattachment of the painted layers. The consolidation procedure implied re-establishing the loss of mechanical strength and improving the internal cohesion of the painted layers. "A consolidator is a substance introduced into friable material to strengthen it and to

stabilize its structure. Dissolved or dispersed in a liquid, it permeates the pores of the object and re-establishes the structural integrity after hardening. Materials used as consolidators are very diverse. Synthetic resins like acrylic or epoxy, inorganic materials and cellulose derivatives, gums, proteins and natural resins are used, depending on the requirements of the material that is to be consolidated." (EwaGlos 2015, p. 370) By brushing and injecting the warm adhesive product, made from animal connective tissue, over the Japanese veil, the paint layers were emolliated. In order to protect the painted layer a thermoplastic foil was put over. The surface was then carefully levelled with a heated spatula, alternating with the application of cold presses (Fig. 5).

After reattachment of the of the paint layer, the removal of the Japanese veil was made.

The first attempt in cleaning the object was done mechanically, with the scalpel and the abrasive pencil. Unfortunately this method took too much time and the risk of harming the fragile surface was high. Therefore different solvents were tested in order to swell the layers. The best results were achieved by dimethyl-sulfoxide ( $(CH_3)_2SO$ ) neutralized by Russian School First Solution. Ingrained dirt on the surface was cleaned by using cotton swabs and solvents. So the layers were swelling and then mechanically removed (Fig. 6, 7). To remove the insoluble layer which was covering the whole surface laser cleaning was chosen. After fixing the intensity of the ray the dirt particles could be physical dislodged and were removed from the surface with the help of brushes and a low vacuum suction. This method reduces the toxicity of the whole system and reduces the potential harming of the object (Fig. 8).

The cleaning brought to light besides the true colours of the *brancovenesc* painting, the damaged conservation state of the painted layer, even beyond our expectations.

The missing areas of the painted layers were filled in to protect the original layers and prepare the surface for aesthetic repair. „Depending on the support, the picture layer, and the kind of retouching techniques that is envisaged, filler ought to be easy to work, and its volume should hardly change when the substance dries. It should be simple to smooth and structure, and its suction action on the

binding agent used in retouching should be controllable. It should respond well to wetting and be permanent. Further it must not discolour and must be easy to remove without damaging the picture layer. At the same time, it must adhere to the ground layer and respond to climate change in similar way to the painting's environment." (Nicolaus, 1998, 237) The filler used consist of a binding agent, skin glue, 6% and a filling substance, mountain chalk, was applied warm with the help of brushes and by spatula, in layers (Fig. 9). A more fluid mix was injected in the flight holes to protect the structure from infiltrations.

This operation was followed by polishing the putty with abrasive paper and cotton buds with egg yolk emulsion (Fig. 10).

The last stage of restoration work, before applying the protective varnish was retouching the defective area of the painting and chromatic integration of the missing parts. The retouching was made with aqueous binding agents. The watercolour technique has the advantage of altering less and can be easily removed. To re-establish the esthetical unity the methods of completion were: neutral retouching, done in a neutral tone matching the original colour, combined with *tratteggio* and *pointillist* style depending on the defective area (Fig.11).

After the artwork regain its aesthetic unity, a protective varnish layer can be applied made from Dammar resin and turpentine. „As in the case of most of the triterpene resins, the dammars make good varnishes; they are used as picture varnishes because of their good solubility in organic solvents and because they yellow to a lesser extent than varnishes made from diterpen resins." (Masschelein- Kleiner 1995, p.72)

All steps taken in the restoration process were in close coordination with the owners wish, the Royal Court National Complex Museum, in Târgoviște, Dâmbovița County, meeting ethical standards in the field of conservation and restoration. The difficulties encountered during the restoration process, because of the degradations occurred due to inappropriate storage conditions and previous restoration interventions, raised important, but also interesting problems to be solved during the ongoing interventions.

## REFERENCES

- Cennini 1997  
Cennini, Cennino, *Tratatul de pictură*, Editura Meridiane, București, 1997
- Masschlein-Kleiner 1995  
Masschlein-Kleiner, Liliane, *Ancient Binding Media, Varnishes and Adhesives*, ICCROM, Roma, 1995.
- Nicolaus 1998  
Nicolaus, Knut, *The Restoration of Paintings*, Ed. Könemann, 1998.
- Pignolo 2000  
Pignolo, Giuliana, *Effetti d'oro - storia e tecnica della doratura nell'arte*, Ed. Compositori, 2000.
- Thompson 2004  
Thompson, V. Daniel, *Practica picturii în tempera*, Ed. Sophia, București, 2004.
- EwaGlos 2015  
*EwaGlos - European Illustrated Glossary of Conservation Terms for Wall Paintings and Architectural Surfaces*, Series of publications by the Hornemann Institute, edited by Angela Weyer, Volume 17, edited by Angela Weyer, Pilar Roig Picazo, Daniel Pop, JoAnn Cassar, Aysun Özköse, Jean-Marc Vallet, Ivan Srša, Michael Imhof Verlag, Petersberg 2015, Germany



### LIST OF ILLUSTRATIONS

1. Royal Doors during restoration
2. Detail; brittleness on the painted layers level
3. Detail; degradations of the painted layers
4. Detail; degradation on the painted layers and varnish level
5. Detail; consolidation of the painted layers
6. Detail; cleaning
7. Detail; cleaning
8. Detail; cleaning with laser beam
9. Detail; filling
10. Detail; finishing of the putty with abrasive paper
11. Detail; retouching

### LISTA ILUSTRĂȚILOR

1. Ușile Împărățești în timpul restaurării
2. detaliu; fragilizare la nivelul straturilor picturale
3. detaliu; degradări ale straturilor picturale
4. detaliu; degradări la nivelul straturilor picturale și verni-ului
5. Detaliu; consolidarea straturilor picturale
6. Detaliu; curățire
7. Detaliu; curățire
8. Detaliu; curățire cu fascicul laser
9. Detaliu; chituire
10. Detaliu; șlefuirea chitului cu hârtie abrazivă
11. Detaliu; integrare cromatică



1. Royal Doors during restoration



3. Detail; degradations of the painted layers



4 Detail; degradation on the painted layers and varnish level



2. Detail; brittleness on the painted layers level



5. Detail; consolidation of the painted layers



6. Detail; cleaning



7. Detail; cleaning



8. Detail; cleaning with laser beam



9. Detail; filling



10. Detail; finishing of the putty with abrasive paper



11. Detail; retouching

## IN FRONT OF THE SAMOVAR

Ilie MITREA, PhD \*

Talida- Diana ORIAN \*\*

**Abstract:** *The work „In Front of the Samovar”, by the Transylvanian painter Arthur Coulin was painted in 1898 and is part of the “Brukenthal” National Museum’s collection since January 26, 2013. The painting was donated by Mrs. Johanna Coulin Dubus from Germany, a descendant of the painter. The selection of the piece was made based on its problematics, thus the restoration is perfectly justified and also necessary in order to restore the aesthetic value of the painting.*

*The piece presented problems with the pictorial surface as well as with the support, as the canvas was ruptured, cut and had lost its flatness. The painting was also damaged by previous, inadequate restoration works.*

**Keywords:** Arthur, Coulin, oil painting, restoration

**Rezumat:** *Lucrarea “Femeie în fața samovarului”, semnată de pictorul transilvănean Arthur Coulin, realizată în 1898, face parte din colecția Muzeului National Brukenthal din data de 26.01.2013. Acesta a intrat în colecția muzeului printr-o donație din partea doamnei Elsa Johanna Coulin Dubus din Germania, descendentă a pictorului Arthur Coulin. Selecționarea aceste piese s-a făcut pe baza problematicii pe care o prezintă, astfel că intervenția de restaurare este perfect justificată și necesară pentru a-i reda valoare estetică pe care aceasta o are.*

*Lucrarea prezenta probleme la nivelul stratului pictural dar și la nivelul suportului, pânza fiind spintecată și tăiată, prezentând o pierdere a planeității, dar și intervenții de restaurare anterioare, neadecvate.*

**Cuvinte cheie:** Arthur, Coulin, pictură în ulei, restaurare.

The painting “Woman in Front of the Samovar” by Arthur Coulin is an easel painting and represents a gender scene executed at the end of the 19<sup>th</sup> century during the Transylvanian stage of his work. (Iulia Mesea, 2010, p. 24). Displayed at the Winter Salon in Budapest between 1898 and 1899, the painting representing Coulin’s wife, attracted the attention of the public and critics. (Fig.1) The composition of the painting is very well balanced, in both shape and color showing that the artist used a naturalist manner of painting (Iulia Mesea et al, 2012– 2013, p.372)

The entire operation has been made in Brukenthal Museum laboratories, guided by Mr. Ilie Mitrea, Expert Restorer.

The restored work was first scientifically researched. It was studied visually in both natural and artificial lighting, and using glasses with and

adjustable magnifying glass. The whole operation was accompanied by photographic documentation for the areas that were later restored. The surface of the piece was also studied using X-Rays. After analysing the results, we established a diagnosis and made proposals for the future restoration.

The chassis is made from fir wood and is 91 cm tall, 57,5 cm wide and 5 cm thick. The joint system is a tongue-and-groove one; it has a glide path and tension garland. Not all the tension wedges were original. (Fig.2) On the chassis there are three blue and black marks, four old tags with an unreadable writing and a new tag with the inventory number 3228. Due to inadequate manipulation, the chassis has scratches and nail holes.

The canvas was anchored to the chassis with different sized metallic needles. In the upper left side the canvas was untied most likely to apply the

---

\* Muzeul Național Brukenthal, Sibiu; e-mail: iliemitrea@yahoo.com

\*\* Student at Faculty of Social and Human Sciences “Lucian Blaga” University of Sibiu, Romania; e-mail: talida.diana@yahoo.com

patch.

The work shows previous attempts of restoration in both pictorial surface and canvas, in some cases inadequate. (Fig. 3) Time and inadequate preservation led to the formation of adherent and superficial dirt and cobwebs. Dust had mainly accumulated at the base of the painting between the support and chassis.

The work has a thin layer of ground applied on the surface of the canvas.

The entire surface of the canvas was covered in dust and dirt, which made the subject very difficult to see. On the surface of the canvas there were several areas with wrongly executed chromatic integrations, without cleaning the gloss paint, the dirt and dust. The result was an anaesthetic one. Also, the surface of the painting suffered physical mechanical degradations (Florea Oprea 2010 p. 102) there were several areas presenting scratches, holes and exfoliation as well as matte areas of the gloss paint.

According to the results of the chemical analysis, the white stratum contains lead white pigment, the red stratum from the scarf of the subject contains red mercury pigment (vermilion), and the ground contains pigments based on iron (earth) and white lead.

In order to diagnose the painting, I examined it visually and using a magnifying glass under direct light and also under UV lamps.

The X ray of the painting shows that the composing elements of the initial subject were mostly respected, the only modifications being made at the subject's hand and face. The previous chromatic integrations can also be seen. (Fig. 3)

The dust from the surface of the painting was removed using a soft brush and light strokes in order to prevent exfoliation. To clean the back of the painting we used a soft brush and a light vacuum. Because the upper left corner of the painting had been untied from the chassis and there was also a patch from a previous restoration, the canvas needed to be stretched. We took it from the chassis and removed the patch with warm water and a scalpel. (Fig. 4, 5)

Under the patch there was a Z-shaped cut. After removing the patch, we were continued with removing the adhesive leftovers with the scalpel.

The cut was repaired using adhesive thermoplastic glue Beva 371 (mixture of microcrystalline wax and synthetic resin) scalpel and a thermic spatula. (Fig.6)

There was also a smaller cut and a hole in the bottom left side. These were repaired the same way as the first cut.

In order to prevent damage during the repair of the cuts, I used the facing operation. To do the facing we used Japanese foil and 5 % clay, applied with the warm brush.

Due to the large fluctuations in relative humidity that has been subjected to the cloth, it has lost flatness on bottom left corner and a pattern of crackles was formed. Glue skin loses its strength at high levels of relative humidity and strong tension develops when dehydrated. (Mecklenburg 2009, p.110). To restore the flatness of the canvas, I used alternative hot-cold bolsters using damp strips of spongy paper, the iron, polyester film (Melinex type) , and for the cold bolsters we used a bag of sand. (Fig 7)

The surface of the painting was cleaned using several methods. The most efficient were: ammonium water, 2% concentration (to remove dirt), and 40% ethylic alcohol, 60% pine tar oil (cleaning old varnish layer and painted areas).

After cleaning the dirt and tailing-out the gloss paint, I filled the empty spaces with an adhesive made from 6% leather clay and mountain chalk. Because the stratigraphy of the work did not need an imitation of the strokes, the luting was made using a fine brush. The excess was removed using a slightly damp cotton stick and circular motion.

After the luting, the affected area was chromatically integrated using watercolours, followed by general varnishing with dammar varnish paint with brush until the dissolvent had completely evaporated. The second retouching was made in varnish colours. (Fig. 8)

Through conservation and restoration operations, condition and aesthetic pieces were restored. With the support of Mr. Ilie Mitrea Expert Restorer, we managed to relate the seemingly complicated situations encountered during the work, being basically a happy joint approach and combination of theory with practice.

## REFERENCES

- Mesea 2010 Iulia Mesea, *Arguments for a new art*, In: Arthur Coulin, Braşov, 2010
- Mesea et al. 2012-2013 Iulia Mesea, Alexandru Gh. Sonoc, Valentin Muresan, *Recent additions to the art collections of the Brukenthal National Museum (October 2012- october 2013)*
- Florea Oprea, 2010 Florea Oprea, *Etiopatogenia operei de arta și a materialelor structurale*, Bucureşti, 2010, Ed OSIM, p.102
- Mecklenburg, 2009 Marion F. Mecklenburg, *Microclimate locale si deteriorări ale picturii induse de umiditate*. In: Márta Guttmann, *Tendențe în conservarea preventive*, Astra Museum, 2009

### **LIST OF ILLUSTRATIONS**

1. Before restoration
2. Tension wedges
3. Previous chromatic integrations
4. Removing patch by wetting
5. Removing patch by scalpel
6. Consolidation support with adhesive thermoplastic glue Beva 371
7. Flatness restore
8. After restoration

### **LISTA ILUSTRĂȚILOR**

1. Înainte de restaurare
2. Pene de tensionare
3. Integrări cromatice anterioare
4. Îndepărtarea petecului prin umezire
5. Îndepărtarea petecului cu bisturiul
6. Consolidarea suportului cu adeziv Beva 371
7. Redarea planeității
8. După restaurare



1. Before restoration



2. Tension wedges



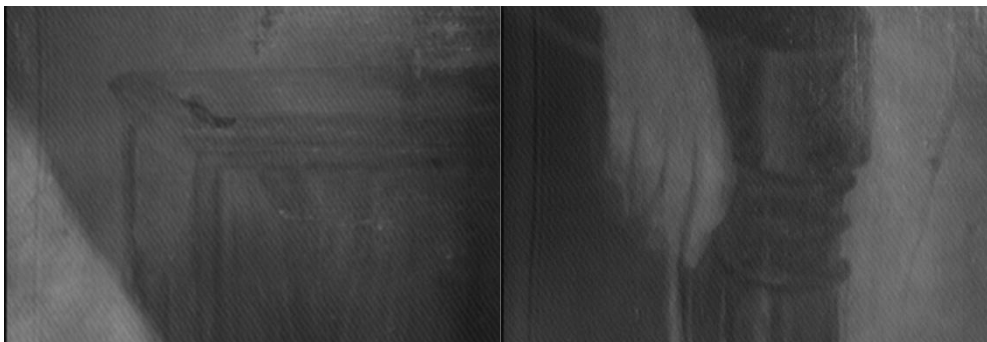

3. Previous chromatic integrations



4. Removing patch by wetting



5. Removing patch by scalpel

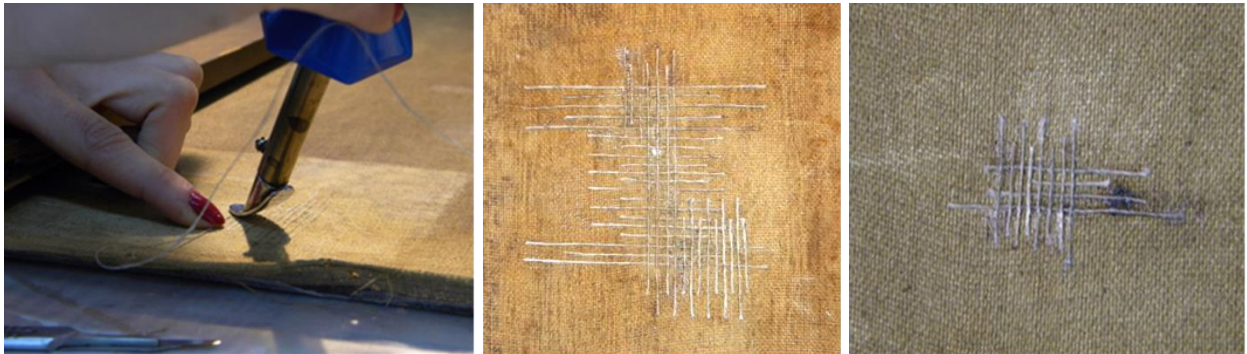

6. Consolidation support with adhesive thermoplastic glue Beva 371



7. Flatness restore



8. After restoration



## DEGRADATIONS OF THE ART OBJECTS ON WOODEN SUPPORTS IN THE COLLECTIONS OF THE BRUKENTHAL NATIONAL MUSEUM DUE TO IMPROPER CONSERVATION AND RESTORATION INTERVENTIONS

Cristina Daniela SCĂRLĂTESCU Drd \*

**Abstract:** *The paper presents the results achieved following the choice of improper restoration methods, examples of objects with a wooden support, for whose restoration improper materials were used, even if not necessary, all these consisting in irreversible degradations, in addition to the ones produced, in time, by the realisation technique or the environment.*

**Keywords:** *wood, altar, furniture, degradation, restoration, principles*

**Rezumat:** *Lucrarea de față prezintă rezultate la care s-a ajuns în urma alegerii unor metode necorespunzătoare principiilor restaurării, exemple de piese cu suport din lemn, pentru restaurarea cărora au fost folosite materiale improprii, chiar dacă nu era necesar, acestea constituind degradări ireversibile, suplimentare celor produse în timp de tehnică sau de mediu.*

**Cuvinte cheie:** *lemn, altar, mobilier, degradare, restaurare, principii*

The iconostasis in the Big Royal Church, built by The degradations caused by previous restoration interventions are frequently seen on objects belonging to museum collections.

Due to the methods adopted by the restorers along time, a series of degradations took place, as far as the wooden objects, both religious and profane, like furniture, use concerned, especially as a result of irreversible or partially irreversible materials. According to the principles of restoration, irreversible materials can be used only when there is no other way through which using materials similar to the original ones can maintain the integrity of the objects.

Both objects of religious persuasion, and also furniture and other wooden elements – wooden frames, gilded or protected with several types of lacquers (shellack with or without pigments), belong to this category – often present degradation signs due to the choice of improper repair/restoration methods, the reasons for these choices being relevant only when speaking about respecting the principles of restoration, especially the first and most important one, "Primum non nocere".

Therefore, differenced analysis of these degradations is needed, based on the type of objects and the interventions they underwent in time.

In the case of religious persuasion objects, the degradations due to previous restoration interventions, present on the wooden supports, affected also by the environmental degradation factors and by the human factor along time, consist of completions and consolidations on a mechanical and structural level.

As far as the objects belonging to the collections of the Brukenthal National Museum are concerned, they underwent numerous restoration interventions, which, in the present, constitute new sources of degradation, in most of the cases.

The two altars (retables) from the collection of the Brukenthal Museum, which represent the object for a detailed historical and aesthetic study, are the altar from the St. Mary Church in Boian, Sibiu County and the one coming from Proștea Mare in Sibiu County.

The Boian retable is unique from an artistic point of view, because of the fact that the festive face is executed entirely in the relief technique, and that

---

\*Brukenthal National Museum, Sibiu, email: [scarlatescu.cristina@yahoo.com](mailto:scarlatescu.cristina@yahoo.com)

can make it be taken as a *Schnitzretabel*, belonging to an era in which the retable was not a standard decorating element of the Transylvanian church altars (Firea 2010, 73).

The poliptic altar from the evangetic church in Proștea Mare, Sibiu County, dated around 1480 is an altar with a central tallboy, and the plastic figures have been lost (Kertesz 1991, 69).

On the wooden elements composing poliptic altars level, the panels decorated with polychrome decoration, interventions with a consolidating role have been carried out, which consisted in creating a system of frames and traverses, attached to the support with an adhesive and also with the help of metallic elements (nails, screws) (Fig. 1.2). The addition of these frames played a role in creating a display system for the panels, which have lost their initial position, that of constituent parts of the ensemble, thus being displayed separately.

The new wooden elements produced tensions which had cracks and rifts as an effect on the original support level, that already presented traces of frailness due to the low thickness of the panels and to a xylophages insects attack (Fig. 3, 4), which had weakened the structural resistance of the wood on the entire surface. Another degradation factor is represented by the metallic elements (Fig. 5) used for the attachment of the system of frames, and it produced losses of material and the incurrence of metallic oxides in these areas.

Another category of wooden objects that have suffered, along time, several reparation/restoration interventions is constituted by furniture. Due to the functional role these types of objects fulfil, the degradations determined by the environmental conditions are accompanied by the ones produced by attrition. Thus, the most frequent degradations are present on the structure of the objects level, in the junction areas and, also, on the decorative (plywood layers), or protective layers (lacquers) level. The loss of the cohesive qualities of the adhesives used for the joints, usually animal origin glues, water insoluble, which are dissolved through boiling, transforming into gelatine due to the interruption of the peptide connections (Istudor 2011, 208), is due to the natural aging of the materials and leads, most frequently, to losses of wooden material (Fig. 6). Also, in the case of furniture made from resinous wood tiled with various types of plywood, the tensions created by the natural movement of the wood, variant for the different types of wood, creates tensions which can cause fractures, cracks and even losses of material (Fig. 7).

The interventions on these objects usually had the role of stopping these degradation processes. The use of irreversible or partially reversible materials in order to re-establish the adhesive joints, like polyvinyl acetate, obtained through the polymerization of vinyl acetate (Istudor 2011, 244), Epoxy type adhesives which, on the score of the polymerization process form a rigid, water insoluble and churlish molecule (Istudor 2011, 250), or even polyurethane type adhesives (Fig. 8), create additional tensions on the brittle wood level. Also, the ever more frequent use of synthetic adhesives (available in the form of sticks) that become fluid when heated, insufficiently tested for their use in restoration, create detachments and tensions on the plywood layers level, due to their relatively rapid stiffening in time (Fig. 9).

The wooden frames, decorated with sculpted and gilded elements, or the ones finished and protected with various types of lacquers constitute a type of art objects often treated with less attention, if we think they "only frame" works of art.

None the less, they represent a category of objects that need conservation and restoration interventions, due to the various materials they are constituted from and the way they decay in time. Also, like furniture, they are subject to functional attrition, repeated handling and accidents. The specific degradations for the gilded frames, decorated with sculpted or various modelled materials (ex: stucco) reliefs, but also for the ones finished with lacquers, are most frequently, the losses of constituent materials, like the stucco, or even losses of wood, especially from the areas on the exterior of the objects.

In the case of the frames finished with lacquers, colorations, discolouration, or losses of shine can occur. As far as the degradations, due to previous interventions suffered, along time, by this kind of objects, are concerned, they consist of improper completions executed on the wooden supports or on the sculpted or modelled decorations level (Fig. 10), which create visual imbalances and tensions due to the use of incompatible materials, followed by new detachments of material.

Chromatic integrations, frequently executed with synthetic lacquers mixed with golden pigment, and applied without a previous cleaning of the surfaces, in the case of gilded frames, usually accompany these improper structural completions. These lacquers suffer chromatic modifications in time (colorations), oxidations on the golden pigment level, which create, alongside the physical and chemical degradations on the objects surface, a pronounced visual discomfort.

In the case of the frames finished with shellack (French polish), by the application of successive layers of lacquer, the improper interventions, like the application of new layers of lacquers or chromatic integrations, alongside the degradations due to aging (colouration/discolouration, losses of shine), produce the loss of the initial aspect of the objects (Fig. 11). Some of the frames present improper chromatic integrations, which can constitute degradations on the original materials level, because they are not compatible with the original ones, thus the alteration of the original appearance being lost (Fig. 12).

Along time the restoration methodology has been frequently debated, modified, transformed by the numerous restoration schools. Also, every restorer had, and still has, the possibility to choose between

the various types of interventions and materials available on the market, in specialized stores and not only. Sometimes, the choices can be influenced by the costs of the restoration processes or by the means the restorers find available in order to perform the interventions, like instruments, gear, etc. What remains of the same big importance, irrespective of the difficulties encountered, are the principles of restoration, especially, the most important of them – *Primum non nocere*. We always need to remember that, irrespective to the materials or techniques necessary for re-establishing the structural or mechanical balance, or for the preservation of the initial message of any object with artistic or historical value, we should never produce additional damage in the structure of the object, which can subsequently become a degradation source.

## REFERENCES

- Firea, 2010                      Firea Ciprian, *Arta polipticelor medievale din Transilvania (1450-1550)*, Teză de Doctorat, Universitatea Babeș-Bolyai, Cluj-Napoca, 2010
- Istudor, 2011                    Istudor, Ioan, *Noțiuni de chimia picturii*, Editura ACS, Colecția Științific, București, 2011
- Kertesz 1991                    Kertesz, Andrei, *Altarele și sculptura, Altarul din Proștea Mare, Catalogul expoziției 800 de ani Biserica a germanilor din Transilvania*, Muzeul Național Brukenthal, , Wort und Welt, Sibiu, 1991

### LIST OF ILLUSTRATIONS

1. Detail; frame system and traverse attached to the painted panel
2. Detail; frame system and traverse attached to the painted panel
3. Detail; degradations due to the display system
4. Detail; degradations due to the xylophages insects attack and the display system
5. Detail; added metallic elements
6. Detail; losses of wooden material
7. Detail; losses of wooden material
8. Detail; reattachment with polyurethane foam type adhesive
9. Detail; reattachment on the plywood layer level with synthetic adhesive with fluidity in a warm environment
10. Detail; improper completion on the decoration level of a gilded frame
11. Detail; degradations due to the improper reapplication of protective layers
12. Detail; improper chromatic integration

### LISTA ILUSTRĂȚILOR

1. Detaliu; sistem de ramă și traversă atașată panoului pictat
2. Detaliu; sistem de ramă și traversă atașată panoului pictat
3. Detaliu; degradări datorate sistemului de prindere
4. Detaliu; degradări datorate atacului de insecte xilofage și sistemului de prindere
5. Detaliu; elemente metalice neconstitutive
6. Detaliu; pierderi de material lemnos
7. Detaliu; pierderi de material lemnos
8. Detaliu; reînclieiere cu material de tip spumă poliuretanică
9. Detaliu; reînclieiere la nivelul furnirului cu materiale adeziv sintetic cu încălzire la cald
10. Detaliu; completare neadecvată la nivelul decorului unei rame aurite
11. Detaliu; degradări datorate reaplicării necorespunzătoare a straturilor de protecție
12. Detaliu; integrare cromatică realizată necorespunzător





1. Detail; frame system and traverse attached to the painted panel



2. Detail; frame system and traverse attached to the painted panel



3. Detail; degradations due to the display System



4. Detail; degradations due to the xylophages insects attack and the display system



5. Detail; added metallic elements



6. Detail; losses of wooden material



7. Detail; losses of wooden material



8. Detail; reattachment with polyurethane foam type adhesive



9. Detail; reattachment on the plywood layer level with synthetic adhesive with fluidity in a warm environment



10. Detail; improper completion on the decoration level of a gilded frame



11. Detail; degradations due to the improper reapplication of protective layers



12. Detail; improper chromatic integration

# MUZEUL BRUKENTHAL

## PUBLICATIILE PERIODICE APARUTE DE -A LUNGUL TIMPULUI (INCLUSIV PRECURSORII)

CRONOLOGIE	ISTORIE, ARHEOLOGIE	ARTA PLASTICA	STIINTELE NATURII	ETNOGRAFIE	RESTAURARE CONSERVARE
ANTE 1950		Mitteilungen aus dem Baron von Brukenthalischen Museum 1931-1937 – Neue Folge I-VII 1941 – Neue Folge VIII 1944 – Neue Folge IX-X 1946 -1947 – Neue Folge XI-XII	Verhandlungen und Mitteilungen der siebenbürgischen Vereins für Naturwissenschaften zu Hermannstadt  1849-1945, 95 de numere		
1950-1989	Studii și comunicări, Muzeul Brukenthal, Sibiu  1956, nr. 1 1965, nr. 12 1967, nr. 13 volum omagial, Anuarul Muzeului Brukenthal, 1817-1967 1969, nr. 14 1973, nr. 18 1975, nr. 19 1977, nr. 20 1981, nr. 21	Studii și comunicări, Muzeul Brukenthal, Sibiu  1956, nr. 4, 5 1956, nr. 7, Istoria culturii 1978, nr. 1 1979, nr. 2	Studii și comunicări, Muzeul Brukenthal, Sibiu  1958, nr. 10, 11 1970, nr. 15 1971, nr. 16 1972, nr. 17 1973, nr. 18 1975, nr. 19 1976, nr. 20 1977, nr. 21 1978, nr. 22 1979, nr. 23 1980, nr. 24 + Supliment 1983, nr. 25 + Supliment 1984, nr. 26	Studii și comunicări Muzeul Brukenthal, Sibiu  1956, nr. 2, 3, 6 1958, nr. 8, 9  Cibinium, Studii și materiale privind Muzeul Tehnicii Populare din Dumbrava Sibiului, Sibiu  1966, vol. I. 1967/68, vol. II 1969/73, vol. III 1974/78, vol. IV 1979/83, vol. V	
După 1989	2006, I, 1 2007, II, 1 2008, III, 1 2009, IV, 1 2010, V, 1 2011, VI, 1 2012, VII, 1 2013, VIII, 1 2014, IX, 1 2015, X, 1	2006, I, 2 2007, II, 2 2008, III, 2 2009, IV, 2 2010, V, 2 2011, VI, 2 2012, VII, 2 2013, VIII, 2 2014, IX, 2 2015, X, 2	1998, nr. 27 2003, nr. 28 2004, nr. 29 + Supliment 2006, I, 3 2007, II, 3 2008, III, 3 2009, IV, 3 2010, V, 3 2011, VI, 3 2012, VII, 3 2013, VIII, 3 2014, IX, 3 2015, X, 3		2010, V, 4 2011, VI, 4 2012, VII, 4 2013, VIII, 4 2014, IX, 4 2015, X, 4

ISSN 1842 - 2691



Tipar "ALTIP" - Alba Iulia