



LIMES

FRONTIERELE
IMPERIULUI
ROMAN
ÎN ROMÂNIA

STUDII
ASUPRA
GRANIȚELOR
ROMANE
DIN
DACIA

Pottery and military life.

*The ceramic assemblages from the barracks of
the auxiliary fort at Buciumi, Dacia Porolissensis*

Autor: Dávid Petruț

Dávid Petruț

Pottery and military life

The ceramic assemblages from the barracks of the
auxiliary fort at Buciumi, Dacia Porolissensis

COMISIA NAȚIONALĂ LIMES

**STUDII ȘI CERCETĂRI ASUPRA FRONTIERELOR
IMPERIULUI ROMAN DE PE TERITORIUL ROMÂNIEI**

Vol. 4

Dávid Petruț

Pottery and military life

*The ceramic assemblages from
the barracks of the auxiliary fort
at Buciumi, Dacia Porolissensis*

EDITURA MEGA
Cluj-Napoca
2018

*Această carte a apărut cu sprijinul
Ministerului Culturii și Identității Naționale,
Comisia Națională Limes.*



COMISIA
LIMES
ROMANIA

Editori volum: Felix Marcu, George Cupcea
DTP: Francisc Baja

© Muzeul Național de Istorie a Transilvaniei Cluj-Napoca, 2018

Descrierea CIP a Bibliotecii Naționale a României

PETRUȚ, DÁVID

*Pottery and military life: the ceramic assemblages from the barracks of the auxiliary fort at Buciumi,
Dacia Porolissensis / Dávid Petruț. - Cluj-Napoca: Mega, 2018*

Conține bibliografie

ISBN 978-606-020-043-7

902



EDITURA MEGA | www.edituramega.ro
e-mail: mega@edituramega.ro

C ontents

PREFACE AND ACKNOWLEDGEMENTS.....	7
1. ROMAN PROVINCIAL ARCHAEOLOGY AND THE CONCEPT OF ‘EVERYDAY LIFE’ WITH REGARD TO THE WESTERN FRONTIER PROVINCES AND ROMAN DACIA. A REVIEW OF PRIOR RESEARCH AND CURRENT DEVELOPMENTS.....	9
1.1. Introduction.....	9
1.2. Archaeology, material culture, and the question of everyday life.....	10
1.3. Topics and fields of enquiry pertaining to the investigation of Roman military everyday life.....	12
1.4. The case of Roman Dacia.....	25
1.5. Pottery and everyday life in Roman military context.....	32
1.6. Some conclusions.....	33
2. THE DAILY LIFE OF THE ROMAN SOLDIERS DURING THE PRINCIPATE BASED ON THE SUB-LITERARY RECORD.....	35
2.1. Integrating the written sources.....	35
2.2. The sub-literary record and its categories (papyri, ink writing-tablets, wax tablets, ostraca).....	36
2.3. The military records.....	40
2.4. Garrison life based on the sub-literary record.....	42
3. THE AUXILIARY FORT AT BUCIUMI. GENERAL OVERVIEW AND RESEARCH HISTORY...	45
4. THE POTTERY ASSEMBLAGES FROM THE BARRACKS.....	49
4.1. Methodology and terminology.....	49
4.2. The classification of the vessels (form and fabrics).....	51
4.2.1. The tableware (including the terra sigillata).....	58
4.2.1.1. The local production.....	58
4.2.1.2. The terra sigillata.....	63
4.2.1.3. Other possible imported wares (thin-walled vessels, glazed vessel).....	76
4.2.2. The utilitarian ware (including the amphorae).....	79
4.2.2.1. The local production.....	79
4.2.2.2. The amphorae.....	84
4.2.3. The cookware.....	90
4.2.4. Non-food-related pottery containers (including lamps).....	95
4.2.4.1. Washing basins.....	95
4.2.4.2. Incense burners (<i>turibula</i>).....	96
4.2.4.3. Miniature vessels.....	97
4.2.4.4. The lamps.....	99
4.2.5. The assemblage published in the 1972 monograph.....	102

4.3. Functional aspects. Evidence concerning the use of pottery vessels and lamps.....	104
4.3.1. Technological aspects related to functionality.....	104
4.3.2. The physical traces of use.....	106
4.3.3. Aspects regarding the culinary practices and evidence of conviviality.....	107
4.3.4. Military pottery?.....	110
4.3.5. The evidence related to the use of artificial lighting.....	113
5. THE POTTERY SMALL FINDS.....	117
5.1. Introduction.....	117
5.2. Bronze casting tools.....	118
5.3. Pottery counters.....	119
5.4. Pottery sling-shots (<i>glandes</i>).....	122
5.5. Spindle whorls.....	127
5.6. Terracotta figurines.....	127
6. CONCLUSIONS. POTTERY AND EVERYDAY LIFE IN THE FORT AT BUCIUMI.....	129
LIST OF FIGURES.....	131
LIST OF PLATES.....	133
ABBREVIATIONS USED IN THE TEXT AND THE CATALOGUES.....	135
BIBLIOGRAPHY.....	137
PLATES.....	157

Preface and acknowledgements

It may be argued today that the lion's share of sources with regard to everyday life in the military environment of the Roman provinces during the Principate is provided by the archaeological record and material culture. However, in order to claim that we are in fact exploring the relationship between human behaviour and material culture, it is essential to move beyond the traditional positivistic and taxonomic approach which sees the end goal of finds analysis in the setting up of local and global typological classifications. While classification is an absolutely necessary research tool, in order to assume the perspective of the peoples and communities whom we are allegedly studying, it is vital to focus on the use of the respective objects, i.e. their functionality, as well as their origin (together with the supply mechanisms) both at an individual and a quantified level. Indeed, for instance, the fact that public dining, drinking and gaming was taking place just outside the headquarters building of the fort in Porolissum in the upper storey of building C3, would have been impossible to detect without the detailed analysis of the finds in addition to their thorough recording. Moreover, only by interpreting the patterns in material culture can we get closer to the day-to-day life of the people we refer to as 'Roman soldiers' and thus help to unravel the distorting uniformity of our perception of Roman civilisation, and of current antiquity reception as a whole. Asking the right questions will eventually lead to the realization that 'the Roman army is not what we think it is', as Andrew Gardner put it.¹

The investigation – carried out in the framework of a PhD research programme at the Babeş-Bolyai University in Cluj between 2010 and 2014 – is focused on the material culture yielded by the barracks of the auxiliary fort at Buciumi on the north-western frontier of Dacia Porolissensis, which emerged between 1971 and 1976, the final period of the systematic archaeological surveys at the site that began in 1963. Given that the only larger pottery assemblage from the fort was published in the monograph of 1972, the bulk of the ceramic material has hitherto remained unprocessed. The fort at Buciumi is to this day among only a handful of military bases in Dacia, where the barracks were subject to comprehensive research. As such, the present book originally set out to offer a new perspective on the daily life of a military community from northern Dacia through the careful analysis of the material evidence it left behind, and thus underscore some of the diverse features which characterize the internal life of the province's garrisons. Needless to say, these goals were only partially met. Due to the strict deadline of the PhD submission, the archaeological evidential base was reduced to the previously unpublished pottery finds from the barracks, i.e. the vessel assemblages and the small finds. Moreover, given the fact that we are dealing with excavations carried out many decades ago, the somewhat sketchy nature of the finds' recording effectively prevented a precise plotting of the material. All in all the adverse circumstances gave way to improvisation, some of the methods and results may prove to be lasting (at least for a while), others less so. The choice to build the current investigation on the evidence of the pottery finds was based on three main aspects: 1) the shortage of pottery studies dealing with the military

¹ Gardner 2007a, 16–17.

environment of Roman Dacia, 2) the availability of a complete assemblage pertaining to fort barracks, and 3) the intrinsic potential of pottery studies with regard to revealing aspects of everyday life. Beyond the contingency inherent to the forming of the archaeological record and its composition in terms of finds, pottery studies can be a source for a long list of subjects concerning the daily life of the soldiers: supply of goods, use of space, production, military diet and conviviality, daily routine and aspects of military identity.

Given the subject of the book, and the shortcomings of keeping to a monographic perspective, the investigation was extended to include the theoretical aspects and implications of everyday life studies in archaeology as well as the crucial informational base provided by the sub-literary record. Accordingly, Chapter 1, entitled 'Roman provincial archaeology and the concept of "everyday life" with regard to the western frontier provinces and Roman Dacia. A review of prior research and current developments', is meant to be a critical evaluation of the evolution of 'everyday life studies' in Roman provincial archaeology. Chapter 2, entitled 'The daily life of the Roman soldiers during the Principate based on the sub-literary record', is a review of the written record attributed directly to the members of the military communities throughout the Empire, such as the Vindolanda writing-tablets, the wax tablets from the legionary base at Vindonissa, the ostraca from North Africa, and the military papyri of Dura Europos and Egypt. Chapter 3 comprises the review of the research carried out inside the fort at Buciumi, while Chapter 4 contains the analysis of the pottery assemblage, based on the four main functional categories ('tableware', 'utilitarian ware', 'cookware', and 'non-food-related containers'), a review of the assemblage published in the 1972 monograph, and the analysis of functional aspects pertaining to the material. The final section prior to the conclusions, Chapter 5, comprises an analysis of the pottery small-finds, centred on various classes of objects not covered in the previous part, i.e. other than vessels. All drawings and photos were made by the author unless specified otherwise.

For the help that I have received during the work on this volume, throughout my PhD studies period and beyond, I wish to express my gratitude to the following persons and institutions: Professor Nicolae Gudea, one of the excavators of the site and my doctoral supervisor, dr. Mariana Egri, for the indispensable guidance in dealing with the material, to Professor Dénes Gabler from Budapest for the help in the assessment of the terra sigillata, to dr. Małgorzata Daszkiewicz and dr. Gerwulf Schneider (Excellence Cluster Topoi, Berlin) for establishing the provenance of the sigillata assemblage through chemical analysis, as well as the administration of the County Museum of History and Art Zalău and especially dr. Horea Pop for readily providing access to the finds. The financial support for the research was provided by the Sectorial Operational Programme for Human Resources Development 2007–2013, co-financed by the European Social Fund, under the project number POSDRU/107/1.5/S/76841 with the title 'Modern Doctoral Studies: Internationalization and Interdisciplinarity'. The publication of the volume was made possible by the Limes Commission of the Romanian Ministry of Culture, the National Museum of Transylvanian History, and the personal support of dr. Ovidiu Țentea, dr. Felix Marcu and Szilamér Pánczél. During my time as a PhD student I have benefitted from a three-month visiting student fellowship at the University of Cambridge, Faculty of Classics under the advisership of Professor Martin Millett in 2013, and a one-month scholarship at the Hungarian National Museum in November 2011 under the supervision of dr. Ádám Szabó, granted by the Domus Hungarica Scientiarum et Artium, department of the Hungarian Academy of Sciences. I wish to thank them both for all their support and guidance. I also want to convey my thanks to Dorottya Nyulas, dr. Silvia Mustață (Babeș-Bolyai University) and Béla Sánta (University of Liverpool) for meticulously proofreading the manuscript and providing indispensable help in enhancing it, and to Emese Apai for the drawings on Pl. 32/3 and 34. Finally, I want to thank all my friends and colleagues in archaeology who are too many to name and from whom I have learned the most throughout the past decade and a half.

1 • Roman provincial archaeology and the concept of ‘everyday life’ with regard to the western frontier provinces and Roman Dacia. A review of prior research and current developments²

1.1. Introduction

Developments in Roman archaeology throughout the last decades have brought about considerable change in the research concerning the Roman army, the emphasis on the institutions and organization, coupled with a prosopographical approach being gradually balanced out by a somewhat new outlook based on ‘underlying social tensions and ties’.³ Current tendencies are characterized by a gradual shift from the nearly exclusive focus on the military exploits of the army towards a more complex approach centred on the way of life of the soldiers’ communities which made up the Roman army. Accordingly, every unit stationed in a fort, fortress, fortlet or elsewhere, is above all a community with a specific way of life and a common identity manifested through clothing, use of space, display on funerary monuments, etc.⁴ On a theoretical level, identity can be defined as a medium through which agency (i.e. the individual’s conscious capacity for action) and structure (i.e. the wider physical, social and cultural world) can interact.⁵ Alongside the concept of community, lately, the notion of identity, adopted from social theory together with all its theoretical implication, has been increasingly used to bridge the gap between us and the soldiers of the Roman Empire.⁶ By virtue of archaeological, epigraphic and iconographical investigations, numerous aspects of this military identity have hitherto been pointed out (see below), however, other communal identities (e.g. the community of origin, family, etc.) as well as personal self-identity is equally important to the subject at hand, although more tedious to chart based on material remains (see below).

The features of military everyday life were by no means constant throughout the period comprising the Late Republic and the age of the Principate, but were directly linked with the changes occurring in the Imperial policy regarding the army itself, the frontiers and the relations with neighbouring political structures and populations (see below). The historical context which determined the coordinates of military life during the 2nd and 3rd centuries AD, can be identified in the evolution of Rome’s policy regarding the frontiers of the state starting with the latter stages of the Augustan era. The military setbacks which marked the closing years of the aforementioned period, especially

² The current chapter is based in part on an updated and edited version of Petruț 2012.

³ Haynes 1999a, 8.

⁴ Haynes 1999a, 7–8; James 1999, 18; Coulston 2004, 134–135, with regard to the multiple levels of the Roman soldiers’ communal identity.

⁵ Gardner 2007a, 18.

⁶ Gardner 2007a, 15–20.

the catastrophic defeat in the Teutoburg Forest in AD 9, and the costly unrests in Illyricum started a few years earlier brought to an end the period of rapid expansion of the Empire, determining the institution of what we now know as the Limes (although not yet in the sense of a reinforced border at this point) and the temporary slowdown of further sustained conquest.⁷ In the context of the gradual stabilization of the Empire's borders, the network of temporary marching camps (*castra aestiva*) and semi-permanent winter quarters (*castra hiberna*) essential during active campaigns, was gradually replaced with a network of permanent auxiliary forts and legionary fortresses.⁸ These military installations represented the setting for the everyday life of the soldiers, ensuring relatively stable environments for both the legionary and auxiliary troops. Their permanent nature prompted a specific development of their architectural features, their use of space and the daily routine, which in turn determined the way of life of the soldiers who made up the garrisons of the bases.

The topic under scrutiny here has benefited in recent times from considerable input thanks to advances made in the interpretation of the archaeological record and of the sub-literary sources, changing our perspective on the materiality of the Roman army and its implications on the daily life of the soldiers. The intention of the current section is to point out the main approaches and fields of enquiry pertaining to this subject in the western areas of the Empire and in the province of Dacia. The generic term of 'western frontier provinces' includes in this case Roman Britain, the German provinces, Raetia, Noricum and Pannonia. Occasionally, evidence from the Near East and North Africa in the form of sub-literary sources (papyri and ostraca) will be referred to, and a more detailed account of these sources will be given in the next chapter.

1.2. Archaeology, material culture, and the question of everyday life

The concept of 'everyday life' was originally introduced as an individual line of enquiry within sociological theory by the phenomenological sociologist Alfred Schutz (1899–1959), by sociologist Erving Goffman (1922–1982), as well as by followers of the so-called ethnomethodological school.⁹ According to *The Cambridge Dictionary of Sociology* (2006), the notion comprises the sum of regular and ongoing human activities, such as work routines, interpersonal demeanour, also encompassing items of material culture for instance clothing and decor. Consequently, the term implies a contrast with extraordinary situations, such as holidays, days of mourning, war or disaster.¹⁰ A further very important aspect is the emphasis on interpersonal relations, as opposed to other forms and levels of interaction, such as the relations between institutions or states.¹¹ Similar developments in the historical sciences during the interwar period, especially the emergence of the Annales School in 1929 and its emphasis on social history and close ties to ethnography, established the framework for everyday life research from a historical perspective.¹² The prolific series entitled *La vie quotidienne*, published by Librairie Hachette is revealing in this regard.¹³

⁷ See Johnson 1983, 2–3; Luttwak 1979, 7, 49–50. This notion was challenged by Isaac (1992, 372–377), who argued against the inexistence of a unitary concept developed to 'defend and enhance the security of the Empire', suggesting that Roman frontier policy persistently aimed at expansion, throughout the 1st century AD and beyond. For an overview of the debate see Freeman 1996 and Whittaker 2004, 28–32. At any rate, the relative stabilization of the frontiers and the gradual emergence of stone fortifications on the Limes is evident starting with the reign of Claudius and reaching its climax under Hadrian, when the bulk of the infantry auxiliary units were moved on the frontier line, see Lander 1984, 5–67.

⁸ Johnson 1983, 2–3; Lander 1984, 11.

⁹ CDS, 180, 248–50; DSU, 337; ESCA, 864.

¹⁰ CDS, 180.

¹¹ DSU, 337.

¹² Nicoară 2002, 67.

¹³ It is interesting to note the common interest of the Annales School and New (Processual) Archaeology in cultural evolution, systemic change and long-term processes (*longue durée*).

The study of everyday life in archaeology is based mainly (although not exclusively) on a cultural-anthropological perspective, and involves investigating the way of life of communities within their own cultural contexts. It might be argued that certain aspects of the topic were conceptualized and brought to the forefront of research in the context of the discipline's awaking critical self-awareness set off by New Archaeology, the movement which eventually developed into what is known today as Processual Archaeology starting with the 1960s.¹⁴ Awareness of various aspects of everyday life has been central to scientific archaeology since its beginnings marked by the vivid interest of Danish pioneer archaeologists Christian Jürgensen Thomsen (1788–1865) and Jens Worsaae (1821–1885) in the evolution of prehistoric life during the first half of the 19th century.¹⁵ This trend, based on the concept of enquiring archaeological finds on how human beings lived in their prehistoric environments, as opposed to just employing artefacts as dating devices (a practice adopted by the early phases of Palaeolithic studies),¹⁶ was continued with variable intensity by the subsequent stages of archaeological development marked by cultural evolutionism, and later by the culture-historical paradigm (i.e. 'Culture History').¹⁷ The topic was subsequently picked up with fresh impetus by the modern and postmodern (i.e. 'processual' and 'post-processual') developments throughout the latter half of the 20th century, especially due to its emphasis on the question of cultural change and the mechanisms of human behaviour and their detection in the archaeological record.¹⁸ This seems only natural given the central role played by notions of everyday life in cultural interpretation mainly through material culture, understood as a passive reflection of culturally determined behaviour.¹⁹ According to the definition put forward by James Deetz in the processual tradition, material culture encompasses all aspects of our physical environment shaped by culturally determined behaviour,²⁰ or according to recent developments in the post-processual critique: by the interaction of agency and structure (which followed an earlier emphasis on individuality and agency).²¹ Furthermore, the Post-Processual interpretative concept whereby material culture is not merely a reflection of past social realities, but an integral and conscious component of both our personalities and our social lives, and as such is meaningfully constituted, is also potentially relevant to the present subject.²²

At any rate, the notion of everyday life, although not conceptualized as such, is at the heart of cultural processes in general. Indeed, according to the *Encyclopaedia of Historical Archaeology* (2002) the somewhat elusive and all-encompassing concept of everyday life in archaeology comprises 'the essence of culture'. As reported by the same work, it can be described as 'the study of those activities and behaviours that support survival both biological and cultural'.²³ Accordingly, this vast area of research in archaeology comprises a considerable number of topics, such as: living quarters, architecture, furnishings, art and decoration, medical care and sanitation, culinary cus-

¹⁴ Trigger 1989, 244–247; Gamble 2001, 25–30; EHA, 304–305.

¹⁵ Trigger 1989, 80.

¹⁶ Trigger 1989, 101.

¹⁷ Gordon Childe (1892–1957) famously criticized 19th century British and French evolutionary archaeologists for being more interested in artefacts than in their makers (Trigger 1989, 172–173).

¹⁸ Barrett 2006, 144–146. It might be argued at first glance that processual archaeology, due to its primordial interest in cultural processes and cultural change and its general strive for a wider outlook was not too keen on enquiring on aspects of daily life; however, certain approaches central to this school of thought, such as the focus on how the archaeological record was formed – a central concern of so-called 'Middle-range theory' (Gamble 2001, 29) – effectively set the scene for the in depth study of the everyday life of past communities.

¹⁹ Bahn 1989; Trigger 1989, 80, 99.

²⁰ Deetz 1996, 35–36.

²¹ Barrett 2006, 141–142; Gardner 2007a, 17–20.

²² Gamble 2001, 36–37.

²³ EHA, 212.

toms, religious and spiritual activity, clothing, leisure, manufacture and crafts, etc. In contrast with the sociological perspective, the archaeological viewpoint takes into account events and aspects that are not necessarily characterized by daily recurrence, hence are not part of the daily life of the individuals in a strict sense, such as war, holidays or disaster, however are essential components of the culture and way of life of the studied communities.²⁴

It is safe to say that the study of everyday life in archaeology is not a field of research per se, but rather a special perspective within the discipline, focused mainly on the social, everyday realities of various communities of people ignored by the literary sources and the manifestation of the numerous levels of their communal and individual identities. In this respect everyday life studies are deeply entrenched in the idea of material culture and materiality, interpreted in the framework set up by the notions of community and identity. It further entails a ground-level perspective on the studied communities, as opposed to the translation of the data into general phenomena placed in macro-historical settings. Everyday life in Roman military archaeology should thus transcend the level set by speculations on what soldiers ate and how they passed their free time, extending to every aspect of their personal, spiritual and social life within the setting of the fort or fortress where they were stationed.

1.3. Topics and fields of enquiry pertaining to the investigation of Roman military everyday life

The everyday life of the Roman soldiers during the period discussed here is closely linked with the fortresses, forts, and fortlets (*castra*, *castella*, *burgi*, etc.) across the Empire, which represented the regular milieu for the overwhelming majority of military servicemen. The interior architectural structures of these military bases where the members of the garrison lived or spent considerable amounts of time in accordance with their specific duties, such as the barracks, the headquarters building (*principia*), the commander's residence (*praetorium*) or the turrets, represent separate, specific settings of everyday life and are essential in the assessment of the daily routine of soldiers. In this case, the elements which offer clues with respect to the subject at hand are the architectural features of the buildings, the interior use of space, the interior furniture, heating and cooking devices (hypocaust, hearths, etc.), as well as the elements of interior decoration (wall plaster, stucco).

The activities comprising the daily routine of the soldiers as part of their specific work responsibilities varied according to the rank and pay grade of each member of the garrison.²⁵ The duties, the pay, and consequently, the way of life differed greatly across the hierarchic spectrum between the unit commander, the centurions, *principales*, *immunes* and the rank and file (*milites*). Based on the analysis of the written sources (mainly the military records kept on papyri) Roy W. Davies in *The daily life of the Roman soldier under the Principate* (1974) listed the everyday activities that must have taken place in and around the fort on a regular basis. According to the scholar, the list included: military exercises, administrative work, parades and inspections, logistics and supply, manufacture of arms, equipment and additional goods, animal rearing, preparation of foods and guard duty. To this we have to add other activities which took place outside the perimeter of the fort or fortress, mainly on outposts, such as: police work, judicial activity (guarding and escorting prisoners), and scouting on the frontier, tax collection, building work, etc. For obvious reasons however these pursuits are difficult or impossible to detect archaeologically.²⁶ It has to be emphasized that aspects related to logistics and supply of goods as well as the activities linked to

²⁴ EHA, 212.

²⁵ Breeze 1993, 11–12.

²⁶ Davies 1974, 310–330; Campbell 1994, 110–111.

manufacture and crafts also belong to the sphere of everyday life, accounting for a somewhat inclusive approach towards the topic along the lines drawn by R.W. Davies.²⁷

As suggested above, the line of research referred to here as ‘military everyday life’ is part of the wide area of investigation concerning the frontiers of the Roman Empire labelled as Roman Frontier Studies in Anglo-Saxon research, and Limesforschungen in German archaeological literature. The earliest works which are relevant to the subject at hand are the fort monographs, which besides the description and reconstruction of the defensive and interior structures of the military installations, also contain the presentation of the archaeological material. The starting point of the systematic research of Roman military frontiers can be traced back to the work undertaken by the Reichs-Limeskommission (RLK) founded in the third quarter of the 19th century, with the purpose of organising the systematic archaeological research of the Germanic Limes.²⁸ Subsequently, the activity of the RLK had a stimulating effect on similar initiatives in Britain and France. Among the results at this early stage, one can mention the fourteen volumes of the series *Der Obergermanisch-Raetische Limes des Römerreiches* published between 1894 and 1937, while for Britain among the earliest works is James Curle’s monograph: *A Roman frontier post and its people. The fort of Newstead in the Parish of Melrose* (1911). A further step was the inception of the Roman Frontier Studies Congress (Limeskongress), regularly held since 1949. Over time the topics and methods specific to the discipline have evolved and diversified, consequently, subjects such as the way of life on the borders, or the interaction between Romans and natives in these regions were integrated into this area of research.²⁹

Currently the field defined by the umbrella term Limesforschungen is not confined to the research of military features, instead it comprises all aspects concerning the life of the inhabitants, both soldiers and civilians, as well as the infrastructure of the border areas, including the economy and the communication system between the Empire and the Barbaricum.³⁰ A significant change of approach occurred at the end of the 1960s and during the early part of the next decade. G.R. Watson in *The Roman soldier* (1969) observed the fact that research up to that point viewed the Roman army as a ‘collection of fighting units’, and no work has dealt with the life in the army from the perspective of the soldier.³¹ In 1974 R.W. Davies, in his abovementioned work, emphasized the fact that the study of the Roman army focused only on military aspects and events in which the army was involved, and ignored the aspects related to the way of life of the soldiers.³² This in spite of the fact that Roman soldiers during the Principate must have spent only a relatively small part of their military service on campaigns and many of them were probably never engaged in battle throughout their careers.³³ The work of G.R. Watson offered a somewhat more traditional perspective of everyday life, focusing more on official aspects of the soldiers’ careers, for instance: structure of the army, conditions of service, the *Rangordnung*, promotion of the soldiers, the chapters having titles such as: ‘Conditions of service’, ‘Religion and marriage’, ‘The soldier in society’. R.W. Davies’ paper, also based on written sources, but focusing more on the sub-literary record, adopted a fresh view on the subject by introducing new topics in the research, such as: administration, logistics, leave and private life.³⁴

As argued above, the investigation of everyday life in the context of the Roman military

²⁷ Davies 1974, 332–333.

²⁸ Johnson 1983, 13–41; Freeman 1996, 465; Freeman 2007, 131–135.

²⁹ Freeman 1996, 465.

³⁰ Hüsen 1992, 33.

³¹ Watson 1969, 9–11.

³² Davies 1974, 301–302.

³³ Davies 1974, 302–303; Isaac 1992, 54.

³⁴ Davies 1974, 299–301.

comprises a large number of intertwining research subjects brought together by a specific outlook focused on the social realities of communities placed outside the reach and interest of ancient authors. Due to its complex nature and lack of theoretical articulation, the topic is reflected in the archaeological literature as a group of wide-ranging research themes, centred on various aspects that determine or influence the daily life within these garrisons. A classification based on the review of the hitherto extant publications includes the following subjects:

- 1) Supply of goods
- 2) Military architecture and use of space
- 3) Military production (manufacture and crafts)
- 4) Military diet and conviviality
- 5) Daily routine and recurrent activities
- 6) Aspects of military identity

The classification is based on both thematic aspects, and aspects which are determined by the nature and evolution of the research. Consequently, a number of topics associated traditionally with the concept of everyday life have not been highlighted separately, being part of one or possibly more of the abovementioned categories.³⁵ The subject of military diet is addressed separately due to the fact that it has received a remarkably large amount of attention from scholars throughout the last decades, thus developing into an autonomous field of enquiry. The investigation of these topics is based on a wide range of sources, including archaeological, written (literary and sub-literary), archaeobotanical and archaeozoological as well as alternative sources.³⁶ The current section does not intend to offer an exhaustive review nor a summary of the literature and results in the aforementioned subjects, but rather to indicate the tendencies and the evolution of the research pertaining to these subjects, as well as to point out the main sources employed in the investigations.

1) Supply of goods (I)

The question of the Roman army's supply system has been at the centre of scientific debates for the past decades. Studies considering this area are concerned with the provision of foodstuffs (mainly cereals, olive-oil, wine etc.), and various other goods, such as pottery vessels and other kitchen implements, lamps, military equipment and weapons, etc.³⁷ The requirements of an army settled in a pacified region were considerably different from the needs of the forces engaged in campaigns, consequently, the supply mechanism must have varied greatly in the two cases.³⁸ In this respect the employment of operational bases can be cited as an obvious distinctive feature which set apart the methods of supply. These were places where the supplies were concentrated, usually near or within the conflict areas and were employed on a large scale during military campaigns,

³⁵ Such topics include: military clothing and equipment, religion and spiritual activity, medical care, leisure, etc. The question of military clothing and equipment is addressed in the subjects regarding the supply of the forts, manufacture and crafts, and military identity; religion and spiritual activity is discussed within the subjects of daily routine and recurrent activities as well as military identity; aspects regarding medical care can be found in all of the categories proposed, while leisure is discussed mainly with regard to daily routine and recurrent activities within the fort.

³⁶ According to the sources employed, the main types of studies which deal more or less closely with the subject of military everyday life, are as follows: 1) fort monographs, 2) analysis of written sources (literary sources, papyri, ink tablets, ostraca, inscriptions on military equipment and on various utensils, graffiti and dipinti on pottery vessels), 3) material culture studies, 4) architectural analysis, 5) archaeobotanical and archaeozoological studies, 6) 'thematic studies' (characterized by the use of integrated sources for the purpose of analysing particular subjects, e.g. the presence of women and children in forts or military diet).

³⁷ Breeze 2000, 59; Herz 2002, 20.

³⁸ Egri 2008, 46.

especially from the reign of Augustus.³⁹ The discrepancy between the two situations has recently received increased attention in the archaeological literature addressing this subject.⁴⁰

From the point of view of the present study the peacetime supply of the army, which developed in the same historical context as the other features of military everyday life (see above) is of interest.⁴¹ Investigations in this field have put forward two diverging models for Roman military supply.⁴² The first model is based on the existence of a centralized supply system established in the 1st century AD, composed of a hierarchical structure involving *frumentarii*, *beneficarii*, the financial administration of the province (mainly the *procurator Augusti*) and in the case of extra-provincial supply, the *praefectus annonae* based in Rome.⁴³ According to César Carreras Monfort, the centralized system functioned at two distinct levels: the supply from within the province was supervised by the *procurator Augusti*, while the provision of goods from outside the province was coordinated by the *praefectus annonae*. The exponents of an alternative model argue against the existence of a centralised system of supply before the 3rd century AD, maintaining that in this period the procurement of goods for the army was carried out at either a provincial level, or by the individual units.⁴⁴ Moreover, there are numerous documented instances in which soldiers individually managed the personal procurement of goods from family members and friends, as shown by some of the letters comprised in the Vindolanda tablets.⁴⁵ The relationship between the supply of basic foodstuffs and additional goods, such as pottery vessels, has been conclusively addressed in the case of Roman Britain by David J. Breeze. According to the scholar, the 'official supplies' within the province, consisting mainly of staple foods such as cereals, were governed by state regulations, while the adjacent 'unofficial' supplies, consisting of pottery consignments and other goods delivered mostly by private merchants, used the same trade routes and infrastructure to reach the army, being regulated solely by the market.⁴⁶

2) Military architecture and use of space (I)

The main objectives of studies focused on the internal structures of forts and fortresses are: the assessment (or reassessment) of the functionality pertaining to certain architectural structures, furthermore, the evaluation of the internal architectural topography of these military bases during the subsequent construction phases, and the analysis of aspects such as the interior furnishings and decoration, heating and sanitary installations, as well as the construction technique of the respective buildings.⁴⁷ As already mentioned above, the structures which played the most central role in the day-to-day life of the soldiers are the barracks (Figure 1). The classical work by David P. Davison, *The barracks of the Roman army from the 1st to 3rd centuries A.D.* (1989), represents a cornerstone for the study of barracks, although the investigation focused mainly on the spatial and architectural analysis based on the plans of the structures, and only to a much lesser extent on the investigation of everyday activities based on a contextual analysis of the archaeological features and finds from the barracks' interiors. During the last two decades, however, numerous attempts emerged to 'push open the door' into the barracks, by means of close archaeological observations

³⁹ Regarding the role of the operational bases see Roth 1999, 169–177; Egri 2008, 46–48.

⁴⁰ E.g. Roth 1999. Concerning the supply of the army during military campaigns.

⁴¹ See also Johnson 1983, 232; Herz 2002, 19–20. Both authors argue that fundamental changes in the supply system of the army date from the reign of Augustus.

⁴² Egri 2008, 45–46.

⁴³ Carreras Monfort 2002, 76–83.

⁴⁴ Roth 1999, 264; Breeze 2000, 63; Whittaker 2002, 205–209.

⁴⁵ Birley 1997, 277–279; Pearce 2002, 933.

⁴⁶ Breeze 2000, 62–63.

⁴⁷ Manning 1975; v. Petrikovits 1975; Hoffmann 1995; Wilmott 1997; Shirley 2001; Hodgson 2002.

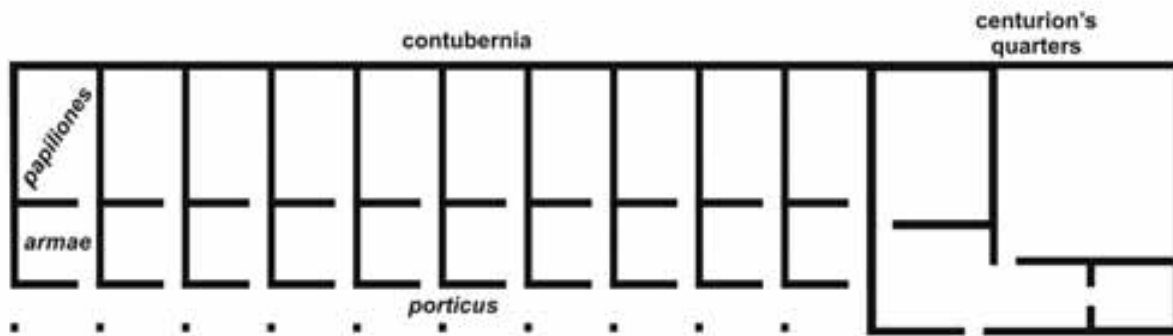

Figure 1. The plan of a typical auxiliary barracks block during the 2nd-3rd centuries AD.

and the analysis of material assemblages (see below).⁴⁸ Nevertheless, studies are regularly based on the architectural interpretation of archaeological data, most often without taking into account the finds produced during the excavation of these edifices.

Detailed architectural examination of various structures have led throughout the last decades to the reassessment of numerous constructions from a functional point of view, the most notable examples coming from Roman Britain, Lower Germany and Raetia. On Hadrian's Wall, investigations have revealed the presence of an edifice inside the auxiliary fort at Birdoswald hitherto known only from the work of Vegetius, i.e. the *basilica exercitatoria*.⁴⁹ Through the comprehensive archaeological analysis carried out in the forts at South Shields and Wallsend⁵⁰ on Hadrian's Wall, as well as in Dormagen (Lower Germany) and Heidenheim (Raetia),⁵¹ the long-standing debate concerning the accommodation of the horses within the forts which garrisoned cavalry troops, debate known in the literature under the title 'Where did they put the horses?', after being first addressed by Colin M. Wells in 1978, was eventually clarified to a certain extent. The results showed that contrary to the assumptions generally accepted until then, in the cited examples – in some cases at least – the horses were housed in 'stable barracks' ('Stallbaracken'), i.e. in the same building as the troopers, and not in separate stables or outside the fort, as it was suggested before.⁵²

Research in this field has shown that our knowledge regarding the interior buildings of forts and fortresses, based mainly on the results of old excavations and the information from the literary record, especially Pseudo-Hyginus, can be fundamentally revised by close observation of the archaeological and architectural features of these structures. It is important to bear in mind however that just as in the case of the literary and sub-literary record, generalizations based on archaeological data are also prone to errors, and there is no guarantee that this method was generally spread throughout the Empire, especially considering the low number of documented cases.

3) Military production (*manufacture and crafts*) (I)

Studies included in this category address the issues of production of goods linked directly with the army and based in the forts or in the close vicinity of military installations.⁵³ The question of

⁴⁸ E.g. Sommer 1995; Hodgson 2002; Hodgson/Bidwell 2004. For a summary of the architecture of 2nd-3rd century barracks, see Petruț et al. 2014, 68-70.

⁴⁹ Wilmott 1997, 582-585.

⁵⁰ Hodgson 2002, 887-889; Hodgson/Bidwell 2004, 136-140.

⁵¹ Sommer 1995.

⁵² Hodgson 2002, 887-889.

⁵³ In this case the army was directly involved in, or at least coordinated the process of production, consequently, this subject is treated separately in the archaeological literature from aspects regarding the supply from independent manufacturers.

military manufacture and crafts was addressed hitherto according to two aspects: the pottery production attributed to the so-called military workshops (*figlinae*) and the production and/or repair of weapons and military equipment in the large scale workshops within the forts, referred to as *fabricae*.

The underlying model concerning military pottery production during the 2nd and 3rd centuries AD is based on the presumption that every fort had its own production centre situated in the adjacent civilian settlement, which was supposed to meet the basic requirements of the garrison in terms of ceramic products, including the bulk of kitchen- and tableware, lamps and other implements used on a daily basis by the soldiers. So-called 'special categories', consisting mostly of fineware, such as terra sigillata which could not be produced by the local potters, were supplied from the outside (i.e. imported) as part of the chain of long-distance trade used directly or indirectly by the state to supply the troops (see above). One of the major weaknesses of this binary model however is that it downplays further possibilities and explanations for the origin of the fort's material culture, especially the 'baggage' brought along by the troops upon their arrival to their post. Furthermore, bricks, tiles and other ceramic building material (CBM) were thought to have been produced only by certain troops and distributed regionally.⁵⁴ The measure of involvement by the military in the local pottery production is still a matter of debate.

Accordingly, an important feature of military production which received considerable attention from scholars is the question of the so-called 'legionary ware' ('Legionswäre'), i.e. the production of pottery for or by the military, based in the immediate vicinity of military installations.⁵⁵ The term was coined by Elisabeth Ettliger in her 1951 study on the pottery assemblage from the Vindonissa rubbish-heap ('Schutthügel'), and even though its validity was since contested on numerous occasions, to this day it offers the best account for the differences which set apart the military pottery production from the civilian one in certain periods and regions.⁵⁶ The aforementioned author's assessments were based on the observation that pottery assemblages from numerous sites associated with the presence of legionary fortresses, or with a high concentration of auxiliary units, display highly similar features while differing completely from the ceramic material of the civilian sites belonging to the same region.⁵⁷ Conventionally, legionary ware is defined as a heterogeneous group of pottery produced around forts and fortresses of the Rhine and Danube Limes as well as Britain, starting from the late 1st century onwards (early-Flavian period), manufactured by potters associated with the military as private contractors, possibly *immunes*.⁵⁸ The hallmarks of legionary ware are: a marked preference for red-slip ware drawing on terra sigillata forms (often late Italian sigillata), barbotine and stamped decoration, imitation of metal (most often bronze) and glass vessels and decoration techniques, moulded vessels, as well as a high percentage of cultic vessels and lamps.⁵⁹ These military workshops were also responsible for the production of tiles and other ceramic building material.⁶⁰

Moreover, the auxiliary fort at Carnuntum yielded a pottery workshop situated close to the north-western corner of the headquarters building. Analysis showed that the products of the respective workshop are consistent with the category of legionary ware, although it cannot be excluded that the short-lived *figlina* functioned in a period when the fort did not serve a primarily military role.⁶¹ In addition, there is also relatively consistent epigraphic evidence for the existence

⁵⁴ Marcu 2004, 585.

⁵⁵ Swan 2004, 260.

⁵⁶ Ettliger 1951, 105. For a critical standpoint on the issue see Greene 1977, 126; Swan 2004, 260.

⁵⁷ Ettliger 1951, 105.

⁵⁸ Breeze 1977, 136–137; Swan 2004, 278; Meyer-Freuler 2013, 373.

⁵⁹ Ettliger 1951, 108–110; Gassner/Jilek 1997, 303; Swan 2004, 260–261.

⁶⁰ Swan 2004, 260.

⁶¹ Gassner/Jilek 1997, 302.

of military potters, the ranks of *magister figlinarum* and *custos figlinarum*, as well as the collective status of *immunes figlinae*, being attested in several forts from Lower and Upper Germany, thus supplying some information regarding the organization of these pottery workshops.⁶² The name of the category has often been the source of confusion, as it suggests the exclusivity of legionary units within this phenomenon, consequently terms such as ‘military ware’ or ‘military pottery’ would be more appropriate, although considering the lengthy literature addressing this issue over the past decades a change in terminology can only be brought about by a surge in the investigation of this phenomenon accompanied by a reconsideration of its magnitude and significance.

One of the main questions regarding the subject of military equipment until relatively recently was whether the problem can be defined in terms of production or of supply, i.e. the workshops within the forts were responsible for the production of equipment or merely for repair and maintenance? In the latter case it was suggested that the equipment was supplied from the outside by independent manufacturers and merchants.⁶³ Through the correlated analysis of archaeological sources, consisting mainly of scrap metal and half-finished items, but also ingots, crucibles, moulds and tools discovered in and around forts, and sub-literary sources (papyri and the Vindolanda tablets) it was determined however that during the 2nd and 3rd centuries AD military equipment was produced locally in the workshops of the forts situated on the Rhine, on the Upper Germanic-Raetian Limes (*Obergermanisch-Raetische Limes*) and in Roman Britain.⁶⁴ An essential role in this process was attributed to the recycling of scrap metal which ensured the necessary raw material for the activity of the *fabricae*.⁶⁵ The exceptional care towards this waste material is shown by the careful deposition of scrap metal in pits and ditches upon the demolition and abandonment of forts in order to avoid its use by potential foes.⁶⁶ It has also been pointed out that additional production activity, for instance hide processing was commonplace in military *fabricae*, as proven by the investigations at Hofheim in Upper Germany.⁶⁷

4) *Military diet and conviviality (I)*

The aspects included under the heading ‘military diet and conviviality’⁶⁸ comprise both the technical features of food preparation, dining and drinking (‘military diet’), as well as its social significance (‘conviviality’) in the context of the military communities, often combined with ancillary activities, such as gaming and probably gambling. The former has received the attention of scholars of Roman military studies with an ever increasing intensity starting from the landmark paper of Roy W. Davies: *The Roman military diet* published in 1971.⁶⁹ Studies focusing on this subject, besides investigating the components of the daily rations issued to the soldiers, also regularly deal with the process of food preparation and consumption, and its impact on the building and reinforcement of communal identities (see below). Davies’ study relied primarily on literary sources complemented by the selective evidence of animal bone assemblages, while data extracted from the sub-literary record comprised of papyri, ostraca and wooden tablets was only sparsely employed.⁷⁰

⁶² Breeze 1977, 136–137. The following ranks are recorded on inscriptions: *cus(tos) castel(li) figlina(rum)* at the legionary fortress in Mainz; *mag(ister) fig(linarum)* at the legionary fortress from Nijmegen; *immunes figlinae* are mentioned on an inscription from Bonn.

⁶³ For the review of the debate, see Bishop 1985, 1–2; Bishop/Coulston 2006, 233–240.

⁶⁴ Oldenstein 1977, 68–86; Bishop 1985, 1–2; Bishop/Coulston 2006, 233–240.

⁶⁵ Oldenstein 1977, 68–86.

⁶⁶ Bishop 1985, 8.

⁶⁷ Bishop/Coulston 2006, 233–240.

⁶⁸ Due to its direct relevance to the main subject of the book, the current section is presented in somewhat more detail.

⁶⁹ Davies 1971.

⁷⁰ At the moment of the paper’s publication a series of essential sub-literary documents have not yet been made

Needless to say, since Davies' study the sources and implicitly the data have multiplied, growing emphasis being placed on both sub-literary evidence as well as faunal and botanical data.

Contrary to the approach employed in the aforementioned study, 'Roman military diet' is not viewed today as a monolithic concept or a unitary phenomenon throughout the Empire,⁷¹ the acknowledgement of regional and chronological variations playing a key role in current interpretations.⁷² Evidently, a series of common features converging on Mediterranean traditions can be accounted for, which are relatively constant on military sites throughout the Empire, extending beyond regional barriers by means of long-distance trade and the mobility of the troops. This is the case of commodities such as wine, olive oil, seafood or exotic fruits, evidence for their use regularly emerging even in military bases from the northern regions. The common features of the Roman soldiers' daily diet would probably include: the 'military bread' (*panis militaris*) described by Pliny the Elder and derived from the daily rations of wheat or other types of grain issued to the men as fundamental staple, furthermore, a certain amount of meat, possibly cheese, olive oil, and potentially wine or some substitute such as *posca* made from vinegar or sour wine and water or even beer on the northern frontiers.⁷³ It has to be noted that the analysis of the Vindolanda writing-tablets by James Pearce has revealed a high level of discrepancy between the written record and the faunal evidence in the case of Roman Britain.⁷⁴ This underpins the view that, a 'standard military diet' is impossible to outline even in the case of a single province which incidentally provides both extremely rich archaeological as well as written evidence in this matter.

The collective dining routine of the Roman soldiers is mentioned, albeit somewhat in passing, among others, by Josephus Flavius in his laudatory digression on the organisation and strict discipline of the Roman army during the 1st century AD given in the *Jewish Wars*.⁷⁵ Recent tendencies in the research emphasize the fundamental role of communal dining in the forging and strengthening of collective identities among the soldiers.⁷⁶ As noted by Maureen Carroll, the preparation, cooking and consumption of food and drink in the company of their fellow soldiers from the *contubernium* 'helped to structure and reinforce communal experience and group identity'.⁷⁷ It is a well-known fact however that Roman forts and fortresses provided no central facilities for the preparation and the consumption of food and drink, most evidence pointing to the fact that cooking, at all stages, from grinding the wheat to dining was carried out collectively by the members of each *contubernium* in and around the barracks.⁷⁸ The discovery of various cooking utensils in the barracks, consisting of a large number of millstones, and isolated finds of bronze saucepans and bread stamps inscribed with either the name of the *centuria* or, in many cases, that of the *contubernia*, has the potential of corroborating this notion.⁷⁹ The investigation of conviviality in a military setting has been to a certain extent thwarted by modern concepts regarding military

public, e.g. Robert O. Fink, *Roman Military Records on Papyrus* (1971); Robert Marichal, *Les ostraca de Bu Njem* (1992), or not least the Vindolanda wooden tablets of which the first one was only discovered by Robin Birley in 1973.

⁷¹ Davies 1971, passim. Regarding the concept of a unitary military diet during the Principate see Junkelmann 1997, passim; Carreras Monfort 2002, 71–72.

⁷² Pearce 2002, 931–932.

⁷³ Davies 1971, 125; Roth 1999, 42–44; Pearce 2002, 941.

⁷⁴ Pearce 2002, 939.

⁷⁵ Josephus, *JW* 3.86.

⁷⁶ For a detailed review of conviviality in a military setting, see Mustața et al. 2014, 225–228.

⁷⁷ Carroll 2005, 363.

⁷⁸ Johnson 1983, 197; Davison 1989, 242–243; Roth 1999, 44; Carroll 2005, 363–367.

⁷⁹ The instances of finds related to food and drink preparation and consumption which bear either the name of the individual soldier or that of a unit within the garrison as signs of ownership have been reported in great numbers during the last decades mainly from sites in Britain and Germany. The finds include inscribed vessels, centurial bread stamps and a large number of millstones, see: Johnson 1983, 199; Davison 1989, 241; Carroll 2005, 364.

discipline reflected onto our interpretation of the past. According to this paradigm, Roman military installations were hermetically sealed microcosms, governed by a martial ambient, thus the possibility for the soldiers to experience any worldly enjoyment lay exclusively outside the forts' gates, most often in the neighbouring *canabae* or the *vici*.⁸⁰ The hypothetic analogy between the Roman army and modern military thinking and practice,⁸¹ beyond the presumed 'modernity of the ancient Romans', which lies at the heart of antiquity reception, can be traced back to the German beginnings of Roman Frontier Studies, intimately linked with the newly unified German state's aspirations for military grandeur, which led to a close collaboration between the RLK and various structures of the army.⁸² This is epitomized by the complete rebuilding of the Roman auxiliary fort at Saalburg between 1897 and 1907, under the patronage of Kaiser Wilhelm II.⁸³

Recent interpretations have set out to nuance this notion. Moreover, an increasing amount of archaeological and sub-literary evidence points to the fact that 'feasting' was in fact commonplace inside the perimeter of forts and fortresses, although the question of the exact physical setting is still undecided. The fact that the households of the commanding officers (*praetoria*) were usually furnished with *triclinia*, allowing for proper banquets (*convivia*) to be organized for the officers, their families and the occasional high ranking guests, is well documented in the archaeological literature.⁸⁴ Possible instances of feasting and even banqueting outside of the commander's household were documented archaeologically in the forts at Echzell, Masada, Ravenglass and the legionary fortress at Vindonissa/Windisch (hereafter Vindonissa). Inside the barracks from the auxiliary fort in Echzell on the Upper Germanic-Raetian Limes, one or possibly two rooms from the centurion's quarter were interpreted as being *triclinia*. The rooms dated to the reign of Hadrian or Antoninus Pius contained very elaborate wall paintings depicting mythological scenes, and a vaulted roof, specific to *triclinia* and unprecedented for the rooms of barracks.⁸⁵

A somewhat related situation was reported from the Roman siege camps at Masada. There, the *contubernia* of the semi-permanent barracks consisted of short masonry walls being roofed with tents, in order to maintain a cool temperature.⁸⁶ Each *contubernium* was furnished with masonry *triclinia*, thus, accounting for an unparalleled situation in the Roman Empire. Ian Richmond noted that the primary purpose of the *triclinia* was that of beds for sleeping, although alternatively they could have been used for reclining at dinners as well.⁸⁷ A proper *convivium* is, however, difficult to imagine in these very small enclosures, the rooms displaying average dimensions of approximately 2.5 × 3 m.⁸⁸ A further documented situation which entails aspects of conviviality comes from Northern Britain, at Ravenglass. In one of the barracks of the auxiliary fort, a group of 126 gaming counters was discovered on the burnt floorboards of a *contubernium*. The finds

⁸⁰ See the discussion in Allison 2006, 1–2. Some accounts referring to the rule of Hadrian (see Speidel 1996, 79), relate the fact that the emperor ordered the removal of *triclinia*, colonnades and ornamental gardens from the forts and fortresses, in order to strengthen discipline, following a visit to the troops on the Rhine in AD 121. It was asserted that during the 1st century AD this type of facilities frequently existed in the military bases of the Empire, see v. Petrikovits 1975, 108, 143–144; Speidel 1996, 79.

⁸¹ See Luttwak 1979.

⁸² See Freeman 2007, 133–134. State militarism was by no means exclusive to the Kaiserreich at that time, however the connection between the centrally coordinated (and financed) investigation of Roman military installations and the promotion of the dominant political and cultural values of the period, is more conspicuous than elsewhere.

⁸³ Hüsen 1992, 33.

⁸⁴ Johnson 1983, 133–135. See also the writing-tablets containing invitations to banquets and the inventory of goods acquired in preparation for convivial events discovered in the *praetorium* of the Cohors IX Batavorum in Vindolanda (Bowman 1994, 65–70; Birley 2002a, 128, 151–152).

⁸⁵ Davison 1989, 240, 245; Speidel 1996, 79, note 29.

⁸⁶ Richmond 1962, 146.

⁸⁷ Richmond 1962, 146; Carroll 2005, 367.

⁸⁸ Richmond 1962, 146.

could represent one or more sets, possibly jointly owned by the respective group of *contubernales*.⁸⁹ Furthermore, the writing-tablets from Vindolanda mention the presence of a brewer (*cervesarius*) in the staff of the unit, possibly as an *immunes*.⁹⁰

Probably the most intriguing situation related to the subject at hand was reported in the legionary fortress at Vindonissa in the province of Raetia. There, a virtually unique correlation between the locally discovered written sources, and the archaeological record of the fortress has produced the most straightforward evidence so far regarding taverns operating within the compound of Roman military bases. The start of the enquiry was prompted by the analysis of three wax tablets discovered together with numerous similar finds in the rubbish heap ('Schutthügel') of the fortress (RSV 44, 45, 47). The first tablet is a fragment of a letter containing only the data of the receiver. According to the text, the letter was to be delivered to a person named Belica (probably a native woman), next door to the baths: *con{c}t{fo}ra balneu(m)* (RSV 44). Correspondingly, in the building opposite to the main entrance of the baths, a large number of gaming counters, dice and kitchen utensils were discovered.⁹¹ If indeed the settings match, then it can be said that the respective building housed an establishment for public drinking, eating and gaming where a female barmaid or innkeeper called Belica worked.⁹² The other two wax tablets reinforce this image. The second text is a completely preserved invitation addressed to a soldier to participate at a feast. Drinking and gaming is specifically mentioned by the sender, and the address (house no. 12) is given as well. Besides this, a further reference is made to female presence in the opening of the letter. As a means of persuasion, the sender writes: 'think of your barmaid (innkeeper?) at (house) 12' (*Im mentem habe hospitam tuam in XII*) (RSV 45). Considering this text as well, the activity of a brothel in the respective establishment might be implied.⁹³ The third text, also a letter, mentions the presence of a wine-seller or wine-maker (*vinarius*) at house no. 13, i.e. next to the house mentioned in the previous letter (RSV 47). The correlated evidence points to the existence of a tavern or a complex of taverns next to the baths of the fortress where women were also employed.

Apparently two separate situations can be distinguished. In most cases, the setting for convivial activity is offered by the barracks, in either the ordinary *contubernia* (Figure 2), or in the centurion's quarter. In one instance, at Echzell, a regular *triclinium* was set up in the centurion's quarter. The case of the legionary fortress at Vindonissa represents a somewhat different situation. There, evidence emerged for the existence of a tavern functioning in a separate structure within the fortress. Accordingly, when investigating traces of conviviality in military installations, a difference must be drawn between two potentially divergent situations. Instances of what appears to be private banqueting can be identified with the events designated as *convivia* which were usually set in *triclinia* and governed by a set of regulations based on social hierarchy and display of privilege and prestige.⁹⁴ Conversely, the discoveries which point to cases of public dining, drinking and gaming should be treated in a separate fashion, as they belong to a different social phenomenon.

5) Daily routine and recurrent activities (I)

The question of daily routine and recurrent activities within forts and fortresses was the main theme of the earliest studies which targeted specifically the subject of daily life of the Roman soldiers.⁹⁵ Throughout the last decades, two lines of investigation emerged in this field

⁸⁹ Davison 1989, 245.

⁹⁰ Bowman 1994, 45, 60, 76; Birley 2002a, 130.

⁹¹ Speidel 1996, 79–80.

⁹² Speidel 1996, 80; Allison 2006, 3.

⁹³ Speidel 1996, 80; Allison 2006, 3.

⁹⁴ Dunbabin 2003, 11–18.

⁹⁵ Davies 1974.



Figure 2. 3D model of a 3.5 × 3.5 m barracks chamber (*contubernium*) designed in Autodesk 3ds Max.

based on two distinctive groups of sources: 1) the sub-literary record and 2) the spatial distribution of the archaeological finds. The sub-literary record⁹⁶ comprised of papyri, wooden inscribed tablets and ostraca, offer the most conclusive evidence concerning life in the forts. To this, the vast record of *instrumentum domesticum* inscriptions has to be added, consisting mainly of incised (*graffiti*) or painted (*dipinti*) inscriptions on pottery vessels, punctured inscriptions on military equipment or other metal utensils, which, although have a lesser impact on a global scale, offer – among other aspects – precious information on the ownership (communal or personal) or way of use of the items.⁹⁷ The analysis of these documents have revealed important aspects concerning the particular tasks and daily activities performed by soldiers and officers as well as aspects concerning the frequent missions involving detachments from the unit, often to other forts. The latter aspect has an important effect on the study of troop mobility within the provinces.⁹⁸

The analysis of the spatial distribution of artefacts often using the Geographic Information System (GIS) places artefacts discarded or lost by the Roman soldiers within spatial, temporal and typological contexts. These help translate the patterns of the material culture and the distribution of the finds, ascribed beforehand to functional groups, into social practices.⁹⁹ This type of analysis was performed at various levels in the case of the legionary fortress Vetera I in Lower Germany, the Raetian auxiliary forts at Ellingen and Oberstimm,¹⁰⁰ and at a somewhat smaller scale at the auxiliary forts in Birdoswald and South Shields on Hadrian's Wall.¹⁰¹ The identification of certain patterns of artefact distribution in various points of the Vetera I fortress has made it possible to

⁹⁶ The next chapter comprises a somewhat detailed account of the informational value of the sub-literary record with reference to the subject at hand.

⁹⁷ Macmullen 1960, 23–25.

⁹⁸ For aspects regarding the question of conviviality in forts and fortresses based on this type of sources see the previous section ('military diet and conviviality').

⁹⁹ Allison 2005, 836–838; Gardner 2007a, 19; Gardner 2007b, 128–131; Giles 2012, 1–2, 35–46.

¹⁰⁰ Allison 2005; Allison 2006.

¹⁰¹ Gardner 2007b, 128–131.

draw conclusions with respect to aspects such as food preparation, dress, the age, gender and status of the persons inhabiting the fortress, as well as to the state of occupancy of the site.¹⁰²

A large scale investigation was carried out across the forts in northern Britain with the intent of identifying activity areas based on the patterns produced by the functional groups of artefacts.¹⁰³ In line with the principles of Behavioural Archaeology, this method allows the identification of cultural processes ('cultural transforms') which acted to create the archaeological record. This method was also successfully employed in investigating the presence, movements and activities of women and children in forts by ascribing gender and status attributes to artefacts. This helped confirm the hypothesis that contrary to our earlier understanding of the Roman army, the forts and fortresses were places of constant interaction between soldiers and civilians.¹⁰⁴ Furthermore, the possibility asserted before, that ordinary soldiers' families were housed inside the forts even before the lifting of the marriage ban for active soldiers under Septimius Severus, could be to some extent validated by the concentration of female and children-related artefacts in the soldiers' barracks, exposed by digitally plotting the archaeological material.¹⁰⁵ The question of women's presence in the forts was addressed on several occasions based on a wide range of textual and material evidence, e.g. by analysing the leather shoe remains from barracks within several auxiliary forts by Carol v. Driel-Murray which revealed considerable amounts of women's and children's footwear inside these structures,¹⁰⁶ or even more eloquently by the discovery of a large number of infant burials consisting of perinatal skeletal remains in contexts pertaining to several periods of the fort at Ellingen, including the floors under the barracks.¹⁰⁷

The contributions of Roman frontier studies to the topic of 'religion on the Limes' have seen some significant progress in recent years. By means of quantitative studies of artefact assemblages aimed at a better understanding of 'on the ground' realities of everyday life in and around the forts has produced essential contributions in certain aspects of the religious practice of soldiers.¹⁰⁸ The basic notion borrowed from prehistoric archaeology, that 'ritual was fundamental to everyday life in a way which is difficult for us to comprehend today' and thus impossible to separate from questions of economy and social organization without imposing our modern mind set on the data, is beginning to gain recognition in Roman military archaeology as well.¹⁰⁹ However, the ideology of spatially segregated types of activities and peoples still dominates the archaeological literature concerning the Roman military. Indeed the main question is: did religion and secular life belong to separate spheres?¹¹⁰ Based on this question we are left with two parallel narratives on military religion: the classical approach, with emphasis on official or 'conventional' religious practice, widely accepted in the archaeological community, and a somewhat marginal line of study concerned with identifying personal, or 'unconventional' aspects of religious practice, which is still looking for recognition.

The study of the so-called unconventional aspects of religious practice relies almost entirely on the quantitative and qualitative analysis of artefacts and artefact assemblages, but also on the willingness on the behalf of archaeologists to consider the symbolic interpretations of deposits

¹⁰² Allison 2005, 836–837.

¹⁰³ Giles 2012.

¹⁰⁴ Allison 2006, 1–2.

¹⁰⁵ Allison 2006, 17–18; Allison 2007, 432–436.

¹⁰⁶ v. Driel-Murray 1997; see also Speidel 1998.

¹⁰⁷ Allison 2006, 14–17; Allison 2007, 408–412. The case of the infant burials in the fort at Ellingen is not unique, similar situations were reported in a number of forts from Britain, namely in South Shields and Malton in contexts dating to the 3rd and 4th centuries.

¹⁰⁸ Clarke 1997; Clarke 2000; Allison 2006; Allison 2007; Allison 2013.

¹⁰⁹ Clarke 2000, 22.

¹¹⁰ Allison 2013, 356.

as opposed to a purely functional approach.¹¹¹ The reinterpretation, proposed by Simon Clarke, of the deposits from the over one hundred pits and wells discovered in and around the fort of Newstead in South Scotland as ritual depositions, is so far the most conclusive example of ‘unconventional’ religious practice inside Roman military installations.¹¹² The systematic bias in favour of the official Roman religion has resulted however in an unexpected counteraction visible in the reluctance of small-finds specialists to address aspects of religion in GIS aided artefact distribution studies. Penelope M. Allison’s extensive and complex study based on a number of forts from Germany, published in 2013, is probably the best example for this.¹¹³

6) *Aspects of military identity (I)*

The question of military identity is considered here primarily for the reason that both personal self-identity and, more essentially, military group identity was displayed at almost every level of the soldiers’ lives. This comprises, among others, aspects such as: clothing and military equipment, culinary practices, use of space and funerary commemoration.¹¹⁴ It seems fair to say that identity expression represented a significant component of the way of life of the members of the military. As suggested above, recent studies in military identity emphasize the coexistence of individual self-identities and of a military ‘communal’ identity expressed at various levels, among which the collective identity shared by the members of the *contubernia* is characterized by the strongest degree of cohesion.¹¹⁵ This in turn is followed by increasingly larger groups as the *centuria*, the unit itself, the regional army group and finally the entire Roman army, depending on the context.¹¹⁶ Both types of identity are marked by specific ways of display, although their degree of overlap is very high. Elements of personal identity can be traced most conclusively with respect to military clothing and equipment, respectively funerary commemoration and display.

Recently, some scholars have stressed the fact that there was no central planning or design of the military garments and armour, and thus the choice of equipment belonged, with some due restrictions imposed by rank (e.g. the *crista transversa* or the *vitis* worn exclusively by centurions), to the individual soldier and his financial potential. Consequently, the concept of ‘uniform’ according to current standards can be dismissed with regard to the Roman soldiers. Instead, the phenomenon is ascribed to the constant movement of the troops, fashion diffusion and exchange, and not to a unitary concept enforced at state level and supported by centralized production.¹¹⁷ This view was extended to the so-called ‘parade armour’, interpreted as an instance of personal option in the matter of equipment embellishment, some scholars arguing that it is unreasonable to think that soldiers possessed two sets of equipment, emphasizing that the use of decorated equipment in battle was in fact practical for a number of reasons, not least because it admittedly helped bolster courage and allowed individual acts of bravery to be recognized.¹¹⁸

The visual marker of funerary commemoration, namely the gravestone or funerary monument, was an important medium for the display of both personal and communal identity. By way of the epitaph and/or the figural relief, it often transmitted facts in which the possessor of the monument took personal pride, such as the place of origin, rank or individual acts of courage performed during the years of service, but also their social aspirations unaccomplished during

¹¹¹ Clarke 2000, 24.

¹¹² Clarke 1997; Clarke 2000.

¹¹³ Allison 2013.

¹¹⁴ Haynes 1999a, 7; Carroll 2005, 363–364.

¹¹⁵ Carroll 2005, 364.

¹¹⁶ James 1999, 18.

¹¹⁷ James 1999, 19; Coulston 2004, 141–145.

¹¹⁸ Coulston 2004, 147.

their lifetime, but realized in their death through the ‘words and pictures’ of their funerary monuments.¹¹⁹ It is important to note however, that identity expression through the tombstones was subject to change, this dynamics being indicated by the differences in the manifestations between the newly arrived occupation troops and the soldiers of already established provincial armies, who have become accustomed with the environment.¹²⁰

It has been emphasized in the recent literature on the subject that there is a clear connection between the forming of the military communities, i.e. the groups of soldiers characterized by communal identity and the efforts of the army to alter the cultural identity of the recruits.¹²¹ According to our current understanding, this was achieved by exposing the recruits to constant propaganda and special symbols, but also by introducing them to a new way of life, which, at least in the case of most auxiliaries, was totally unknown at the moment of enlistment. This included, among others, dietary and drinking habits, hygiene (bathing and grooming), new hairstyle, and generally accommodation to a new and thoroughly organized framework of life represented by the Roman fort.¹²² Thus, it can be said that the way of life to which the soldiers from the legionary and auxiliary units were introduced in the forts contributed decisively to the shaping of the military communities, which in turn were fundamental to the functioning of the Roman army.

Over the last few decades attempts have been made to identify instances of ethnic mobility (mainly through the movement of vexillations) and transfer of cooking traditions within the army through the careful examination of anomalies in the pottery assemblages which cannot be easily explained by the supply pattern.¹²³ The presence of North African cooking vessels in Northern Britain, admittedly to meet the culinary needs of the African troops deployed there by Septimius Severus, the spread of tripod-vessels to the northern provinces and the emergence of the large North Gaulish beaker (‘vase tronconique’) in Britain, particularly with the *Classis Britannica*, were considered by Vivien G. Swan to be illustrations of this phenomenon,¹²⁴ although the objections formulated by Michael Fulford shortly after seem quite reasonable.¹²⁵ Other instances have provided data regarding the predilection of certain units towards particular types of vessels, among the most interesting cases is that of Legio XI Claudia and its possible connection to the wide-spread production and use of pottery washing basins (see below).¹²⁶ At any rate, in theory at least there is no reason to dismiss the possible correlation between certain elements of the material culture and the transitory or enduring presence of outsider ethnic groups.

1.4. The case of Roman Dacia

The newly established province of Dacia underwent from the outset a process of intense militarization, the army asserting its presence at all levels of provincial life. Furthermore, given its specific geostrategic position, namely the fact that it was bordered on three sides by territories beyond the Empire’s administrative limits, and not least because of its specific topography, its defensive system does not seem to display a linear layout as is the case of most other provinces.¹²⁷ According to some scholars, the Dacian Limes was arranged in depth along three concentric lines

¹¹⁹ Hope 1997, 255–258; see also Varga 2016, 79.

¹²⁰ Hope 1997, 255.

¹²¹ Haynes 1999b, 165–167.

¹²² James 1999, 16–17.

¹²³ Swan 1997, 289; Swan 2009, 15; contra Fulford 2010.

¹²⁴ Swan 1997, 291–293; Swan 2009.

¹²⁵ Fulford 2010, 70–77.

¹²⁶ Meyer-Freuler 2013, 365–366.

¹²⁷ Gudea 1997a, 2–3.

of defence,¹²⁸ accounting for the relatively dense network of auxiliary forts spread across the entire province. The results of the recent surveys carried out by the Romanian Limes Commission have brought considerable changes to the layout of the province's frontier line, especially on the north-western sector,¹²⁹ a situation which seems to significantly amend the abovementioned three-tier model (see Pl. 1). All the same, the high density of military bases across the province combined with the longstanding bias of local archaeological research in favour of military sites, has produced a relatively high number of publications in this field, albeit the direct results concerning aspects of military everyday life are relatively scarce so far. This is partly due to the positivist outlook adopted usually in the studies regarding the material culture of the military bases, often amounting to summary presentations of the material with emphasis on the classification and little or no discussion of its significance in the context of garrison life.

This is probably best reflected by the study of pottery assemblages, mostly focusing on imported wares such as terra sigillata, and clearly distinguishable local categories such as the so-called 'Dacian pottery', with very few cases reflecting a quantitative approach translated into the systematic analysis of complete assemblages. Moreover, the ethnical interpretation of material culture, which has been prevalent in the archaeology of Roman Dacia since the mid-1960s has induced a highly distorting affect onto the interpretation of the archaeological record, parts of which (e.g. the hand-made pottery in general, the so-called 'Dacian mug', etc.) were designated as ethnic indicators, and thus, tangible proof for the presence of the autochthonous Dacian communities in all segments of the provincial society, including the army.¹³⁰ This was part of the official historical narrative imposed by the central authorities at the time. Beyond the problem of ethnic labelling, the occasional studies of complete assemblages are usually limited to setting up local typological classifications and identifying analogies for the forms on other sites, which might or might not have anything to do with each other. Needless to say, functional analysis converging on the identification of patterns of use are quite hard to come by. Unfortunately, a comprehensive typological study of the ceramic assemblages discovered in two important auxiliary forts of Dacia Porolissensis, i.e. Gilău and Samum/Cășeiu, has remained unpublished, and for the most part unavailable for researchers.¹³¹ The high informational value of the respective study with regard to the pottery vessel types and the variety of forms encountered on the respective military site is obvious, although the decision to employ 'graphical reconstructions' based on analogies for the illustration of the types, whereby the fragments are presented as intact vessels, is somewhat questionable from a methodological point of view. Furthermore, the classification of the vessels does not take into account the characteristics of the fabrics, which can clearly distort the functional assessment of the types (see Chapter 4.2). The recent publication of the investigations carried out in a group of six barrack blocks of the legionary base at Potaissa/Turda (2012–16), includes a comprehensive report on the pottery vessel assemblage, representing a valuable addition to the research of the subject.¹³² Both aforementioned pottery studies will be considered in some detail in the second part of the present study, especially with regard to the question of 'military pottery' (see Chapter 4.3.4).

Probably the most characteristic publications in this field are the monographic studies concentrating on individual forts and fortresses. Based on their integrated approach, these works should theoretically provide large volumes of data, including interpretative models relevant to the subject of military everyday life. Despite the relatively large number of monographic studies concerning

¹²⁸ Gudea 1997a, 2–3; Gudea 2000, 356.

¹²⁹ See Marcu 2016.

¹³⁰ See Niculescu 2002, 222, 227; Popa/Ó Ríagáin 2012, 60–63.

¹³¹ Cupșa 2009.

¹³² Nemeti et al. 2017, 83–132, Pl. XL–LXXXVI (L. Nedelea).

the military installations of Roman Dacia,¹³³ little effort has been made to interpret the results from the perspective of the former inhabitants of these forts and fortresses. The prospect of such an enterprise is hindered by the deficiencies in the analysis of the archaeological material, since most of these publications lack finds catalogues and ‘specialist reports’, the majority simply overlooking the presentation of the finds altogether, even under the form of illustration. Needless to say, finds analysis is the main source for the investigation of everyday life in the Roman forts, having the potential of illustrating both the common features derived from the relative homogeneity of the Roman material culture and the inherent particularities reflected both at provincial level and at the level of every community, such as that of an auxiliary or legionary base.

Setting up a similar classification to the one put forward above with regard to Roman Dacia poses some difficulties given the considerable discrepancy in the state of research, but still, progress made especially in the last decade allows us to consider all of the abovementioned aspects.

1) *Supply of goods (II)*

The question of military supply has seen little progress so far, mainly because of the reasons underlined above. In a study concerning the consumption and necessities of the Roman army in Dacia Porolissensis, Nicolae Gudea has drawn attention to the fact that Roman army studies in Dacia have largely ignored the subject of necessities and supply of the military, admitting that one of the major deterrents in this case is the inappropriate knowledge of the forts’ internal structure, the function of some buildings, and their successive garrisons.¹³⁴ In addition, the insufficient and sometimes improper studies in the material culture of the forts, especially of the pottery assemblages, can be viewed as significant disincentives as well. The aforementioned author attempted to estimate the requirements of the Roman army in the province based on the dimensions of the forts, the type and size of their presumed garrisons on the one hand, and the estimated daily rations of the Roman soldiers, reflected by the sub-literary records on the other.¹³⁵ The preliminary assertions of the respective scholar, while correct at a general level, are prone to several inaccuracies due mainly to the spatial and chronological extrapolations and generalizations regarding the problem of the soldiers’ daily rations ensued from the use of non-contemporaneous written sources from various regions of the Empire. According to the conclusions of the study, the troops garrisoned in this province were forced to rely on imports to supplement their necessities in foodstuffs and fodder, the hinterland of the province (i.e. Dacia Porolissensis) being incapable of providing for the needs of its army.¹³⁶ Considering our general knowledge of the Roman army’s supply system, this is a highly expectable result given that none of the border regions of the Empire were completely self-sufficient.¹³⁷ Moreover, given that the Roman ‘military diet’, as we understand it, was partially based on a Mediterranean diet, which was for the most part inaccessible directly outside the respective region, the need for imports seems evident.

The import of amphora-borne commodities formed a significant part of the military supply. According to Dario Bernal Casasola’s investigation, the high presence of Hispanic amphorae in Dacia, used for transporting wine and fish sauce (*garum*) from Hispania Baetica and Lusitania is directly connected to the supply mechanism of the provincial army. The question is approached however more in terms of future lines of research rather than of tangible results.¹³⁸ As the author

¹³³ Petruț 2012, 102, note 91. The exact meaning of the term ‘monograph’ is highly debatable, accordingly, it is used here in an inclusive sense.

¹³⁴ Gudea 2005, 185–186.

¹³⁵ Gudea 2005, 187–189.

¹³⁶ Gudea 2005, 190–192.

¹³⁷ Herz 2002, 20–23.

¹³⁸ Bernal Casasola 2006, *passim*.

admits, the prospect for future conclusive results is only possible once a substantial amount of material has been published. An important aspect of this field of enquiry is the question of the *tituli picti* displayed by the amphorae. In this respect, a fragment of a Dressel 20 amphora discovered in the *canabae* of the legionary headquarters from Apulum, bearing a painted inscription with the name of the Legio XIII Gemina, is highly significant.¹³⁹ The respective amphorae were used to transport olive oil produced in Baetica. The occurrence of the inscription displaying the name of the legion – as in the case of a few other similar discoveries from the neighbouring provinces – underpins the notion that individual units were directly involved in the procurement of supplies.¹⁴⁰

2) Military architecture and use of space (II)

The question of the internal structure of forts and fortresses in Roman Dacia has received relatively more attention. Studies in this field are generally aimed at determining the internal planning of the military bases, the function of various buildings, and their construction techniques. A series of studies concerning various building categories from the forts of Dacia, such as the headquarters building (*principia*), the commander's residence (*praetorium*) and the granaries (*horreum*) have been published although virtually no emphasis was placed on the detection of activity-patterns within the respective edifices.¹⁴¹ The assessment of the buildings' functionality was based on archaeological and architectural analysis in which a key role was attributed to the extra-provincial analogies. With regard to the barracks, they have so far benefited from limited research, since the archaeological investigations converge mainly on the defensive works and the central buildings (*latera praetorii*) of military installations.¹⁴² Consequently, the number of fully excavated barracks is very low, the most notable examples coming from Potaissa/Turda, Buciumi, Samum/Cășeiu and Arcobadara/Ilișua, although, in the latter two cases, the archaeological material pertaining to these structures is still unpublished. This is a major deterrent for the investigation of everyday life activities within the barracks of Roman Dacia, although it can be said that this sort of interpretation of the archaeological record was regularly neglected even in the case of structures with fully published material.¹⁴³ The recent publication of the investigations carried out in the group of six barracks in the legionary base at Potaissa/Turda has produced a detailed discussion of the barracks' architecture, including the complete planimetry of one of the structures with the distribution of the *contubernia*, each measuring 8.44 × 3.93–5.76 m.¹⁴⁴

Comprehensive results were achieved by combined geophysical and topographical (digital terrain model or DTM) surveys which in many cases produced quite comprehensible digital layouts of the investigated forts and fortresses. The most complete data was hitherto published in the case of Porolissum/Moigrad¹⁴⁵ and a series of auxiliary forts from the Eastern Limes of Dacia.¹⁴⁶ The examination of the archaeological finds and their spatial distribution within these buildings was only sparsely employed so far, thus, making the functional evaluation prone to uncertainty. Relatively recently a synthesis was published, which drew together the data available until now regarding the internal organization of the auxiliary forts in Dacia.¹⁴⁷ Emphasis was placed on

¹³⁹ Egri/Inel 2006.

¹⁴⁰ Egri/Inel 2006, 192.

¹⁴¹ E.g. Stanciu 1985; Petculescu 1987; Isac et al. 1994.

¹⁴² Marcu 2009, 14–19.

¹⁴³ For a detailed review see Petruț et al. 2014, 70–76.

¹⁴⁴ Nemeti et al. 2017, 31–45 (D. Blaga).

¹⁴⁵ Döhner et al. 2011. Further comprehensive research was carried out in the intervening years, see Opreanu/Lăzărescu 2016.

¹⁴⁶ Popa et al. 2010b; Pánczél et al. 2012; Pánczél 2015.

¹⁴⁷ Marcu 2009.

establishing the function of uncertain structures and the comparative analysis of particular building types both within Dacia and from other provinces, based mainly on architectural observations. Nevertheless, it has to be reiterated that the functionality of some buildings, especially those which are not clearly defined in the literary record, cannot be established based solely on their plan.¹⁴⁸

Following the line established by C. Sebastian Sommer and later by Nicholas Hodgson, the existence of ‘stable-barracks’ was asserted in the auxiliary fort at Samum/Cășeu based on the correlation between the archaeological information, namely the discovery of the elongated pits (interpreted as ‘cesspits’ for the horses in Germany and Britain) and the exposing of archaeological material indicative of the presence of cavalry units and their mounts, namely spurs and a cavalry *spatha*.¹⁴⁹ Along similar lines a method only recently applied for Roman Dacia, i.e. the phosphate-level measurements, have led to the identification of certain structures within the fort from Brețcu (Hu: Bereck), potentially employed as stables.¹⁵⁰ The barracks, as buildings which housed the soldiers, have the highest potential for the study of everyday life. Conversely, they are the most poorly investigated among the internal structures of the forts and fortresses in Dacia, traditionally excavators concentrating on the defences and the central buildings in the *latera praetorii*.¹⁵¹ The case of Buciumi can be cited here as an exception, although, as it will be shown below, the limits of the investigation methods employed at that time (1960s–70s) have seriously thwarted the possibilities of interpretation with regard to the way of life of the soldiers stationed there.

3) *Military production (manufacture and crafts) (II)*

The question of military production has been hitherto addressed mostly in the form of hypothesis. Field investigations have led to the identification of no more than a few hypothetical *fabricae* within the forts, among which the best documented is the so-called ‘barracks no. 5’ (building B5) from Buciumi.¹⁵² Further hypothetical military workshops have been reported in the large auxiliary fort at Porolissum/Moigrad and Arutela/Bivolari in Lower Dacia,¹⁵³ although the lack of the systematic finds analysis correlated with archaeological contexts hinders any precise identification. A particular aspect of military production in Roman Dacia, namely the subject of ‘legionary ware’, has attracted some attention in the archaeological literature. Old excavations dating to the period 1939–40 in the auxiliary fort from Drajna de Sus (Prahova County), built probably at the start of the first Dacian War in AD 101 and abandoned around the time of the death of Emperor Trajan, produced ceramic assemblages which almost 30 years after the publication in 1948¹⁵⁴ were found to be consistent with legionary ware.¹⁵⁵ From an administrative point of view the fort never belonged to the province of Dacia, but its establishment and brief period of operation is closely tied to the occupation and organization of the province. Kevin Greene suggested that the Roman army from the beginning of the 2nd century AD employed potters to ensure the supply of the legions and reduce reliance on civilian contractors, as was the case with the legions operating in the Lower Danube area, where the aforementioned fort was established during the Dacian campaigns.¹⁵⁶ These views have since been revised in the more recent literature (see above), however the employment of military potters in the newly conquered regions does make sense.

Relatively recently, the publication of a pottery assemblage from the legionary fortress of

¹⁴⁸ Isac 2006, 437–438.

¹⁴⁹ Isac 2006, 444–447.

¹⁵⁰ Popa et al. 2010a, 69–70.

¹⁵¹ Marcu 2009, 14–15.

¹⁵² Gudea 1997b, 29, 70.

¹⁵³ Gudea 1997c, 26, 64–65 (Porolissum/Moigrad) and Marcu 2009, 185–186 (Arutela/Bivolari).

¹⁵⁴ Ștefan 1948, 125–135.

¹⁵⁵ Greene 1977, 116–123.

¹⁵⁶ Greene 1977, 124.

Apulum/Alba Iulia has revealed a series of interesting aspects regarding the material culture in the military environment of Roman Dacia.¹⁵⁷ First of all, the study showed that in terms of style and the repertory of forms, a considerable part of the assemblage, belonged to the category of legionary ware.¹⁵⁸ Furthermore, it drew attention to the fact that the local pottery production attributed largely to the workshops based in the nearby Partoș district followed the so-called Norican-Pannonian tradition, accounting for the fact that Legio XIII Gemina was previously garrisoned in Pannonia and craftsmen from the neighbouring province most likely pursued the legion onto its new location.¹⁵⁹ The possibility of identifying the assemblages from barracks in Buciumi with this category has also recently emerged.¹⁶⁰

4) *Military diet and conviviality (II)*

Aspects concerning the military diet in Roman Dacia were addressed recently by means of archaeozoological analysis performed on assemblages from various Roman military sites by Alexandru Gudea.¹⁶¹ The analysis has shown that the livestock population of Roman Dacia was thoroughly reshaped by means of selective breeding and import of improved species. The change is most conspicuous in the case of the bovines, although it can also be detected in the case of ovins and caprins at a somewhat lower level.¹⁶² Based on the nature of the evidence, it was inferred by the author that the Roman army benefited primarily from these changes. With regard to further elements of the diet, both the abovementioned study as well as earlier works assumed from the outset that the results provided by investigations in other provinces can be taken at face value and applied without any critical appraisal to the case of Roman Dacia.¹⁶³ Further aspects related to the subject have been underlined sparsely in studies concerning the supply of foodstuffs to the forts (see above), although there has been no attempt so far to analyse the material record, especially the pottery assemblages from the point of view of eating and drinking habits in the Roman military environment of Dacia. Relatively recently, archaeological investigations carried out in an underground building (known as ‘building C3’) neighbouring the *principia* of the auxiliary fort on Pomet Hill in Porolissum/Moigrad, have led to the uncovering of important data regarding the question of conviviality inside Roman military bases. A close analysis of the finds, comprising large numbers of fine pottery tableware, gaming counters and dice, revealed the existence of an upper storey most likely dedicated to public dining and gaming.¹⁶⁴

5) *Daily routine and recurrent activities (II)*

Concerning the daily routine within the Roman forts of Dacia, very little information was hitherto put forward based on material evidence from this province in the archaeological literature. Regarding the question of medical care, recently a large part of the hitherto published body of evidence, relevant to the subject was collected and analysed in context.¹⁶⁵ The study underlined that there is no conclusive evidence for an organized and constant medical system in the forts from Dacia relying on a professional medical staff. Instead, the archaeological material illustrates a prevalence of personal care and hygiene which, among others could be connected to a possible strategy

¹⁵⁷ Ciaușescu 2006.

¹⁵⁸ Ciaușescu 2006, 146.

¹⁵⁹ Ciaușescu 2006, 143.

¹⁶⁰ Petruț 2016.

¹⁶¹ Gudea 2009. The animal bone assemblages from the following forts were included in this investigation: Micia/ Veșel, Bologa, Largiana/Românași, Brâncovenesti, and Răcari.

¹⁶² Gudea 2009, 110–113.

¹⁶³ Gudea 2005, 189–190; Gudea 2009, 93–94.

¹⁶⁴ Mustață et al. 2014.

¹⁶⁵ Gui 2011.

of illness prevention. It is relevant from this point of view that a high number of toiletry implements have been discovered in the soldiers' barracks.¹⁶⁶ A further important subject is the question of female presence in the forts of Dacia. The investigation of this phenomenon was undertaken along the line set forth by Western European scholars who examined this subject during the last two decades (see above).¹⁶⁷ The study was based on the analysis of artefacts potentially associated with women such as jewellery and adornment items, dress accessories and objects linked to 'female activities'.¹⁶⁸ It showed that the concentration of female-related artefacts mainly in the barracks and the buildings considered to be officers' residence is indicative of more or less constant female presence in the forts of Dacia.¹⁶⁹

6) *Aspects of military identity (II)*

The issues related to the various means of identity expression employed by the members of the Roman military have so far been limited to an epigraphic and, more recently, to an iconographic outlook. The study of epitaphs involving soldiers either as commemorators or as the commemorated has found that only a third of the epigraphic material is linked to legionaries, thus in the vast majority of cases we are dealing with auxiliaries.¹⁷⁰ Furthermore, the analysis has showed that over time the share of soldiers commemorated by their family members increased steadily, while the cases of commemorations by comrades, prevalent earlier, decreased, this situation reflecting the stabilization of the provincial army as well as the increasing intensity of local recruitment.¹⁷¹ The respective investigation was limited to the evidence of the epitaphs, however it is important to underline that the body of evidence, i.e. the tombstones erected by and for the soldiers made use of a multi-dimensional communication, which cannot be understood without the corroborative analysis of the epitaph-, the iconography-, and the type of the monuments, at least in the cases in which this is possible.¹⁷²

A recent study has turned to the analysis of figural representations most often encountered on soldiers' funerary monuments, in search of a potentially common representational language employed by the soldiers and the meaning behind it.¹⁷³ This can be particularly important for monuments and reliefs divorced from the epitaphs which originally accompanied them, especially since the number of 'soldiers' epitaphs' is conspicuously low in Roman Dacia.¹⁷⁴ Apart from the representations involving clearly martial elements such as armour and weapons (e.g. the cuirassed representations of high-ranking officers, or the so-called '*Ringschnallen cingulum*-reliefs') the funerary banquet (*Totenmahl*) representations as well as the simple cloaked representations (in *paenulla*, or *sagum*) are also considered to belong to the representational language employed by active soldiers and veterans on their funerary monuments in Roman Dacia as well as other 'militarised' provinces such as the Rhineland, the Upper and Middle Danube region and Britain.¹⁷⁵

¹⁶⁶ Gui 2011, 125.

¹⁶⁷ Vass 2010.

¹⁶⁸ Vass 2010, 130.

¹⁶⁹ Vass 2010, 139.

¹⁷⁰ Varga 2016, 77.

¹⁷¹ Varga 2016, 78.

¹⁷² Hope 1997, 250–251.

¹⁷³ Gui/Petruț 2018.

¹⁷⁴ The database compiled by R. Varga (2016, 77) comprises 106 inscriptions. See also Gui/Petruț 2018, 115–116.

¹⁷⁵ Gui/Petruț 2018, 135.

1.5. Pottery and everyday life in Roman military context

Before concluding this chapter it is important to outline the role of pottery studies in the research effort aimed at addressing issues directly related to the daily life of the soldiers stationed in the military bases of Roman Dacia, even though I am aware that this involves repeating some assertions put forward in the above section. For this reason references to the situations outlined above will not be given separately here. The case was made in the preface that pottery has the potential of being a source for each one of the subjects in part highlighted above, its abundance and versatility making it an ideal source for the study of daily life. Furthermore, the impressive amounts of pottery produced especially by living quarters and spaces characterized by more or less intense human activity inside forts and fortresses renders the ceramic finds ideal for quantitative investigations. One of the objectives of every pottery specialist report should be to provide information with reference to the activities which can be deduced from the quantification, classification, fabrics analysis and archaeometric analysis of the respective assemblage.

With regard to the question of supply, pottery studies can highlight two distinct situations: the influx of amphora-borne commodities, most often consisting of wine, olive oil, fish sauce (*garum*), and the import of certain fine wares which could not be replicated by the local pottery industry, such as Gaulish, Rhenish or North Italian sigillata, or even hitherto elusive imports from the neighbouring provinces of Pannonia or Upper and Lower Moesia. Owing to the progress achieved in amphora studies over the last decades, it is possible today to determine both the origin and the content of most types occurring in the provinces, thus providing valuable data on the supply networks which integrated the forts of Dacia into the flow of amphora-borne commodities originating from production centres in the Mediterranean and Black Sea region. Apart from this, the identification of products supplied to the forts has important implications for the question of the soldiers' diet. Along similar lines, research in the production and distribution of terra sigillata, occasionally involving X-ray Fluorescence (XRF) analysis has increasingly made it possible to determine the place of manufacture even in the case of fragments lacking potter's stamps or decoration. Needless to say, we are still far from obtaining anything close to a clear picture of the military supply system, and in most cases the identification of imports and their origin is conjectural. Even so, the careful analysis of the pottery assemblages can result in setting up patterns of supply. The implications of pottery analysis on the question of 'military architecture and use of space' primarily concern the functionality of certain structures, the character and amplitude of the pottery assemblages recovered from certain structures being indicative of the activities which regularly took place there. The abovementioned case from Porolissum/Moigrad is quite telling in this regard, the pottery analysis having a decisive role in establishing the function of the building's upper storey. The main problem in this case is caused by the difficulties in identifying the redeposited residual material which infiltrates the structures during the periodical refurbishment of the clay floors. Careful contextual excavations provide the only possibility of getting around this problem, while in the case of old excavations it is extremely difficult to tell apart the material record created inside the structures from the residual material brought from the outside.

The role of pottery studies in revealing aspects of military production is quite obvious if we include under this heading the local pottery production which was meant to supply the bulk of ceramic goods for the everyday use of the garrison. Furthermore, instances of metalworking connected to the activity of the workshops (*fabricae*) can be highlighted through the quantification of crucibles, while textile making is indicated by spindle whorls and loom weights. As far as aspects of diet and conviviality are concerned, pottery assemblages are probably the primary sources along with the archaeozoological and archaeobotanical record, although in order to obtain a more complete picture, their analysis should be carried out in conjuncture with that of the glass and metal

vessels and other kitchen and table implements regardless of the material they were made of. The fact that the lion's share of vessels involved in the preparation and consumption of foods (and possibly drinks) seems indisputable based on the evidence provided by finds processing, although the assessment of proportions is hindered by the marked discrepancies in the way various materials are represented in the archaeological record.¹⁷⁶ There is a general understanding of the way the different types of pottery vessels were employed at either producing or consuming meals, or transporting and storing staple foods. Moreover, the observation of different traces of use, 'wear and tear', most often under the form of cut marks, chipping of the surface, corrosion of the surface or soot covering different areas of the vessel, it is possible to further estimate how the vessels were employed. In certain circumstances it is also possible to undertake chemical analysis of the organic residue preserved in the walls of vessels made from coarse fabrics and thus determine their former content. The occasional ownership marks inscribed on pottery tableware reveal instances of private or communal possession of table implements within the communities of *contubernales*. The question of daily routine was addressed above with regard to the functionality of buildings, while instances of identity display can be revealed by the graffiti inscribed on vessels, future research most likely will expose further ways for the interpretation of pottery finds from the perspective of identity display in the Roman military. Furthermore, although this concept was systematically questioned, the case was made that in certain cases, very precisely defined categories of pottery can lead to the possible detection of specific ethnic groups at the level of the garrison.

1.6. Some conclusions

In the vast research domain concerning the Roman army, two somewhat distinct methods of investigation can be linked to the study of military everyday life. The individual monographic studies of military installations (mainly forts and fortresses) generally provide a detailed analysis of the archaeological finds in the form of specialist reports, but only in few cases do they go beyond this 'primary' stage of investigation. The studies directly aimed at investigating one of the aspects of military everyday life cited above are based on a wider range of methods including the correlation of the respective finds with information offered by other sites and areas, but also a wide range of sources pertaining to the archaeological and sub-literary record. The review of the archaeological literature from Western Europe displays a complementary relationship between the monographic studies, in which the archaeological finds are discussed by means of finds catalogues and detailed specialist reports, and the studies which investigate various aspects of everyday life listed above, often relying on the information provided by the monographic works.

In the case of Roman Dacia, in spite of tangible progress made in recent years, the study of military everyday life is hindered both by the relatively small amount of published archaeological material from forts and by the deficient manner in which this material was often dealt with in the publications, especially the lack of proper specialist reports. Given these conditions, the analysis of the various topics of interest here is prone to considerable difficulties. Moreover, often attempts to consider these aspects are not based primarily on the quantitative analysis of archaeological assemblages, relying instead on the arbitrary adoption of results and hypothesis from Western archaeology. In order to achieve further progress in this field the need to re-evaluate the archaeological

¹⁷⁶ The incidence of intentional discard in the case of pottery objects was clearly higher than in the case of metal (and to a certain extent glass) objects which were prone to recycling due to the intrinsic value of their material. Furthermore, the use-life of pottery vessels was potentially lower due to accidental breakage, while the organized abandonment of sites (especially military bases) could theoretically involve the removal of certain categories of metal objects, such as bronze vessels. Thus it might be argued that pottery objects are overrepresented in the archaeological record. For the life cycle of Roman pottery, see Peña 2007, 6–16.

finds from previously investigated military sites seems essential. Based on a detailed analysis of this material, the investigation of the various aspects of military everyday life, according to the classification put forward here, is made possible. This investigation, made at the level of individual forts, relies primarily on the quantitative analysis of the archaeological assemblages pertaining to the respective sites and the information provided by similar sites and regions of the Empire as well as the complementary data provided mainly by the sub-literary record.

2. The daily life of the Roman soldiers during the Principate based on the sub-literary record

2.1. Integrating the written sources

The assertion that literary sources were in general written by and for the elites has become axiomatic. Texts tend to focus on the affairs of the privileged and powerful, and ignore aspects of the lives of the common people. With regard to the Roman army, the classical texts convey in great detail matters of military organisation, strategy and battles, the social realities of military service being largely ignored.¹⁷⁷ Traditionally the written record has provided the interpretative framework of the discipline, although the picture today is being gradually balanced out by theory.¹⁷⁸ Indeed classical sources are not ‘outside of theory’ and texts are cultural products before anything else, which need to be deconstructed by historians in order to become sources.¹⁷⁹ Nonetheless, Roman provincial archaeology is part of the wider family of ‘historical archaeologies’ and indeed most of what we know of the Roman world is from the written record, i.e. the literary works of the ancient authors and the epigraphic corpus, first introduced into mainstream research by Theodor Mommsen (1817–1903) in the 19th century. Because of the fundamentally different social and cultural circumstances which led to their creation, the historical- and the archaeological record only very rarely overlap, and their complementarity is not at all straightforward. Given the diverging cultural and social perspectives that they illustrate as well as the lack of balance in the quantity of data and its informational value, and indeed their different levels of resolution, by uncritically hammering the two types of sources into one common narrative, we risk to obtain a highly distorted image of the past.¹⁸⁰ The concept whereby our understanding of the past derived from written sources is different from our notions based on the study of artefacts was already formulated in the mid-19th century, by some scholars, particularly by Scottish archaeologist Daniel Wilson (1816–1892), although its echoes were, and still are, quite limited.¹⁸¹

One way of bringing textual evidence and material culture closer within a common approach is to narrow the range of written sources employed to those which present the most extensive similarities to the archaeological material, in that they were overwhelmingly produced and used by the soldiers. The list includes the so-called 1) sub-literary texts (papyri, ostraca, wooden tablets, wax tablets), 2) the graffiti (*instrumentum domesticum*) on various everyday objects and the 3) epitaphs of tombstones and funerary monuments erected for and by the soldiers. The richest, most diverse and most personal information is provided by the sub-literary record comprised of official bureaucratic documents and the personal correspondence of the soldiers. Moreover, many of these documents

¹⁷⁷ Davies 1974, 301–303.

¹⁷⁸ Gardner 2007a, 35; Giles 2012, 32.

¹⁷⁹ Gardner 2007a, 37–38.

¹⁸⁰ Freeman 2007, vi–vii.

¹⁸¹ Trigger 1989, 82–83.

were recovered via archaeological investigations, thus in some cases the textual information they contain can be corroborated by contextual data. The question of graffiti on common objects was discussed with some detail in the previous section, and thus it will not be reiterated here. The problem of the funerary monuments on the other hand requires a complex and lengthy discussion which exceeds the framework of the present study, moreover, it commands an integrated analysis involving not just the epitaphs, but also the choice of monument type and the iconography.¹⁸² The significance of funerary commemoration in a military context concerns, before anything else, the subject of the soldiers' identity, reflected to a certain degree at all three levels mentioned above.

Returning to the sub-literary sources, their integration into mainstream Roman military research began at a relatively late stage, in the 1970s with the publication of Robert O. Fink's corpus of military papyri¹⁸³ centred on the Dura-Europos archive and the gradual emergence of the Vindolanda writing-tablets (see below). Even so, the need for a highly critical standpoint is crucial, especially due to the significant chronological and regional differences in military life reflected in the sources (see Chapter 1.4), all the more so as a considerable part of the sources come from the Near East and North Africa. Accordingly, at first glance it would seem that the largest European corpus of Roman military documents, i.e. the Vindolanda writing-tablets, would provide more suitable parallels with military life in Roman Dacia, however, all things considered, the case of Dacia is probably just as similar as it is divergent with both Hadrian's Wall and Syria or Egypt. Furthermore, the particular geo-political situation of Egypt, i.e. the lack of any immediate external threat and the instability caused by widespread banditry meant that the majority of the soldiers were not garrisoned in forts, but were more or less constantly on patrol. The military architecture from the Middle East and North Africa differed considerably from that of the European frontier regions, moreover, the soldiers from Dura-Europos were garrisoned inside the city itself. It is self-evident based only on these aspects that the coordinates of daily life varied considerably between these regions based on the differences in climate and the interferences with pre-existing cultural models. Even so, as already mentioned, the sub-literary texts are the only direct sources referring to the everyday life of the Roman soldiers, and not taking them into consideration is not a viable option. The current chapter intends to give a brief presentation of the types of documents which can be used for the investigation of the subject at hand, and to outline some possible historical narratives based on this category of sources.

2.2. The sub-literary record and its categories (papyri, ink writing-tablets, wax tablets, ostraca)

The body of textual sources inscribed on papyri, wooden tablets, wax tablets, and ostraca by soldiers, usually in a military setting, in the form of official documents and accounts as well as personal correspondence, often offers direct and relevant information with regard to the regular activities within these military bases. The significance of these documents with regard to the functioning of the Roman army is remarkable in a number of ways. The intense use of written communication and the existence of a complex military bureaucratic system are among the factors that allowed the Roman army to extend military control over a vast area of land employing a comparatively low number of troops.¹⁸⁴ Based on the existing evidence we can assume that the army proactively encouraged acquaintance and regular contact of the soldiers with various forms of writing.¹⁸⁵ For instance, the *principia* of the fort in Gholoia on the Limes Tripolitanus yielded pieces of

¹⁸² Hope 1997; see also Hope 2001, 37–49 and Gui/Petruț 2018, 115–116 with regard to Roman Dacia.

¹⁸³ Fink 1971.

¹⁸⁴ Bowman 1994, 48.

¹⁸⁵ Haynes 1999b, 171–172.

wall plaster containing fragments of the unit's *album* displayed on the wall of the building,¹⁸⁶ while the buildings of the legionary fortress in Vindonissa seem to have displayed numbers in similar a fashion to addresses in our current practice (RSV 45). Instances of 'minor' writing encountered on a regular basis include the issuing of the daily orders and the *tesserae* which contained the daily watchword. Furthermore, the impressive amount of letters which have survived as well as the cordial tone of most of them give the impression that soldiers truly enjoyed writing and receiving letters, admonishing their correspondents for not writing more often or failing to answer their epistles (e.g. TV II, 310, 311).¹⁸⁷ Across the following section a brief account of the main categories of sub-literary sources will be given based on the type of support employed for the documents (papyri, ink tablets, wax tablets, and ostraca), before turning to the content of the documents.

1) There are two major sources of Roman military papyri during the first three centuries AD, Egypt and the garrisoned city of Dura-Europos (today: Sâlihîyah, Syria) in the province of Syria. The papyri from Egypt have raised the attention of antiquarians throughout the last centuries, as shown by the impressive collections based in Europe and the United States. For this reason in many cases the place and circumstances of discovery with regard to these artefacts are unknown.¹⁸⁸ The majority of the Egypt papyri known to us are the result of the interaction between the local population and the provincial authorities and are concentrated in the civilian environment both in a rural and urban setting, the military papyri accounting for only a small percentage of the said material.¹⁸⁹ Among these the most significant are the only two known yearly strength reports (*pridiana*, see below), one belonging to the Cohors I Augusta Lusitanorum equitata, also known as 'Mommsen's *pridianum*', as it was first published by the German scholar in 1892, and the second one issued by the Cohors I Hispanorum veteranorum stationed in Lower Moesia in AD 105, known as 'Hunt's *pridianum*', published in 1925 by British papyrologist Arthur S. Hunt (1871–1934).¹⁹⁰ Furthermore, the most complete and detailed duty roster is kept on a papyrus issued to a *centuria* of the Legio III Cyrenaica (RMR 9), kept at the *Bibliothèque de l'Université de Genève*, which contains the list of activities of forty soldiers over a timespan of ten days.¹⁹¹

The most complete record of military papyri is the archive of Cohors XX Palmyrenorum, stationed at Dura-Europos in Syria, dating to the period between AD 219 and 222.¹⁹² The documents were retrieved between 1931 and 1932, during the excavations carried out by the Yale University and the French Academy of Inscriptions and Letters. The city founded by the Seleucids in Hellenistic times on the right bank of the Euphrates was part of the Roman Empire for less than a century, between AD 165 and 256, its existence brought to an end by a Sasanian siege at the middle of the 3rd century AD.¹⁹³ The unit of archers recruited from the neighbouring city of Palmyra was stationed at Dura probably throughout its entire existence, the troops being garrisoned in the northern sector of the city. The said investigations were focused on the former temple of Artemis Azzanathkona, transformed into an annex of the *principia*.¹⁹⁴ The circumstances for the preservation of the papyri are owed to the defensive measures taken by the defenders, especially the extension of the rampart over several buildings in the vicinity of, or adjacent to the curtain wall,

¹⁸⁶ Marichal 1992, 241–247.

¹⁸⁷ Speidel 1996, 85; Birley 2002a, 106.

¹⁸⁸ Alston 1995, 9.

¹⁸⁹ Maxfield 2003, 154.

¹⁹⁰ Davies 1974, 303.

¹⁹¹ Alston 1995, 96.

¹⁹² Fink 1971, 1; Davies 1974, 303.

¹⁹³ James 2004, 11, 22–25.

¹⁹⁴ Fischwick 1988, 349.

during the final Sasanian siege, which took place sometimes between AD 255 and early 257.¹⁹⁵ The rampart section which incorporated the former temple also sealed the structure determining the preservation of its contents.¹⁹⁶ The overwhelming importance of the Dura papyri, dated to the first half of the 3rd century AD, is illustrated by the fact that more than half of the documents featured in Fink's corpus (RMR) come from the Dura archive, i.e. eighty-three out of the total 134 texts.¹⁹⁷ The material includes four working rosters (RMR 1–4) comprising the complete lists of the troops, the changes occurred in the composition of the unit being indicated through annotations and special symbols employed for this purpose.¹⁹⁸ An equally important document is the so-called *Feriale Duranum*, a list comprising the yearly religious festivals and celebrations, forty-one in total.¹⁹⁹ According to some scholars the nature of the religious celebrations enumerated in the text suggests that the calendar was part of a series of official documents issued to every military unit of Roman army.²⁰⁰ If this is indeed the case the content of the papyrus would be more or less generally available across the Empire for the respective timespan.

2) The wooden writing-tablets, also called 'leaf tablets' or 'ink tablets', displaying texts applied with ink on its surface are archaeologically hitherto only known from sites in Britain, i.e. the auxiliary forts in Vindolanda/Chesterholm (hereafter Vindolanda), Luguvalium/Carlisle, and the legionary base at Isca/Caerleon.²⁰¹ Even so, based on data from the literary sources we can presume that they would have been employed across much of Continental Europe as well.²⁰² Indeed, it is possible that Pliny the Elder himself took notes on such wooden sheets, which he presumably refers to as *sectiles* and *lamillae*, during the time he was an officer in Lower Germany.²⁰³

The ink writing-tablets are inextricably linked with the site of Vindolanda which provided by far the largest number of such finds (see TV I–III and TV IV/1),²⁰⁴ containing data that literally changed the way we view the Roman army. The first writing-tablets were discovered by Robin Birley in 1973, and the number of finds gradually increasing over the subsequent years.²⁰⁵ The high level of the water table and the carpet of bracken and straw which covered the floors in some areas helped create the anaerobe environment which preserved the tablets.²⁰⁶ The fort at Vindolanda functioned between AD 85 and 120 being part of Britain's northern defence line known as the Stanegate prior to the construction of Hadrian's Wall.²⁰⁷ The garrison of the fort successively comprised two units recruited from the Lower Rhine, which subsequently took part in Agricola's campaign. The Cohors I Tungrorum was probably the unit which built the base, remaining in place during its first decades of operation. This was followed by an intermission between AD 95 and 105, during which the fort was occupied by the Cohors IX Batavorum. The last phase of the base was marked by the departure of the Batavians and return of the Tungrians who would remain until

¹⁹⁵ James 2004, 22.

¹⁹⁶ James 2004, 30–33, fig. 9.

¹⁹⁷ James 2004, 5.

¹⁹⁸ Fink 1971, 2–5.

¹⁹⁹ Haynes 1999b, 168.

²⁰⁰ Fink et al. 1940, *passim*; Fishwick 1988, 249–350.

²⁰¹ Bowman 1994, 16, 82; Birley 2002a, 31.

²⁰² Bowman 1994, 16.

²⁰³ Birley 2002a, 33.

²⁰⁴ See the two online databases as well: <http://vindolanda.csad.ox.ac.uk/> and <http://vto2.classics.ox.ac.uk/> (09.08.2017).

²⁰⁵ Birley 2002a, 24–26.

²⁰⁶ Birley 2002a, 22.

²⁰⁷ Johnson 1983, 269–270.

around AD 120/130 before being transferred permanently.²⁰⁸ The writing-tablets are dated from throughout the period during which the fort was operational, being produced by the soldiers and officers of both troops.

The writing-tablets from Vindolanda were employed equally in the internal administration of the fort (for both working documents and official papers) and the personal correspondence of the garrison members. The large quantity of working documents may indicate that the final, official documents were later transferred on other supports more suitable for filing and storage, such as the wax tablets, of which quite a few, i.e. over 250, were also recovered in the respective site (see below).²⁰⁹ At any rate, it seems fair to presume that the ink tablets were overall a more affordable alternative to wax tablets in Britain and quite likely throughout the European continent, being substantially more practical for taking notes and exchanging letters.²¹⁰

The bulk of the ink tablets were discovered in the *praetorium* of Cohors IX Batavorum as well as in the barracks and the *fabrica* constructed upon the return of the Cohors I Tungrorum. We are therefore not dealing with the material of the fort's *tabularium*, kept in the *principia*, indeed the majority of the documents considered here are of personal character.²¹¹ The contents of the documents are directly linked to the routine of garrison life,²¹² the only text referring to military operations is a memorandum on the fighting potential of the native Britons.²¹³ Among the administrative records, the most significant ones are the complete working roster of the Tungrian unit (TV II, 154), the only such document from the European provinces,²¹⁴ the numerous daily reports, referred to as *renuntiae*,²¹⁵ as well as the leave requests and letters of recommendation for the enrolment of certain individuals.²¹⁶ A significant part of the documents is comprised of the personal correspondence of the soldiers which contain equally valuable references to life in the garrison. The most interesting pieces regarding the social life of the soldiers are undoubtedly the ones belonging to the correspondence between Flavius Cerialis, the commander of Cohors IX Batavorum and Aelius Brocchus, his counterpart in the hitherto unlocated fort of Briga, as well as the exchange of letters between their wives Sulpicia Lepidina and Claudia Severa.²¹⁷

3) The so-called wax tablets, also known as 'stylus tablets' are known from a series of sites across the Empire, among others from the mining town at Alburnus Maior/Roșia Montană (Hu: Verespatak) in Roman Dacia, however in terms of military records the bulk of such finds have two sources: the military sites in Roman Britain and the legionary fortress at Vindonissa in Raetia. The impressive number of tablets discovered throughout various regions of the Empire correlated with frequent attestations in the literary (*tabellae ceratae*) and iconographic record indicates that wax tablets constituted a quite common and widespread support for various types of texts.²¹⁸ As mentioned above, it is likely that official military documents were regularly kept and stored on wax tablets, based on the observation that a part of the Vindolanda tablets display ink writing on the frame, suggesting that they were filed according to a certain system in drawers or in crates.²¹⁹

²⁰⁸ Birley 2002a, 41–42; Birley 2002b, 926; see also Bowman 1994, 13.

²⁰⁹ Birley 2002a, 31.

²¹⁰ Bowman 1994, 84; Birley 2002a, 33.

²¹¹ Bowman 1994, 17.

²¹² Bowman 1994, 42.

²¹³ Birley 2002a, 95; Birley 2002b, 929.

²¹⁴ Birley 2002a, 77.

²¹⁵ Birley 2002a, 80–81, fig. 53.

²¹⁶ Birley 2002a, 85.

²¹⁷ Bowman 1994, 75; Birley 2002a, 125.

²¹⁸ Birley 2002a, 32.

²¹⁹ Birley 1997, 274.

The legionary fortress at Vindonissa yielded the largest assemblage of wax tablets belonging to the Legio XI Claudia, with over six hundred finds, recovered from two large rubbish heaps, known as the 'Schutthügel' and the so-called 'Keltengraben', making this the largest collection of Roman military documents from continental Europe.²²⁰ In addition to the tablets, a large number of *styli* was also recovered. Regarding the contents, the Vindonissa wax tablets display a diversity similar to that of the Vindolanda ink tablets. Some of the more interesting pieces linked to the subject of conviviality in a military setting were presented in the last chapter (see Chapter 1.3).

4) Military ostraca have hitherto been discovered in large amounts in two distinct regions within North Africa: Egypt's Eastern Desert and the vexillation fort at Gholaiia/Bu Njem (hereafter Gholaiia) on the Limes Tripolitanus. It is well-known that recording texts with ink on pottery fragments was the most common and affordable method of drawing up different types of documents in these isolated desert areas, before transferring the final documents on papyrus.²²¹ In this sense the relation of the ostraca to the papyri must have been similar to that of the ink tablet and the wax tablets, outlined above. A series of military sites from the Eastern Desert in Egypt have provided an impressive amount of ostraca. At the top of the list are the bases established near the great stone quarries at Mons Claudianus and Mons Porphyrites as well as the detachment of soldiers from Wadi Fawakhir. Furthermore, a large number of ostraca emerged from Pselchis in Nubia, which was probably the station of a detachment of troops with police duties, similarly to Wadi Fawakhir.²²² One of the rubbish heaps of the fort at Mons Claudianus alone has produced over ten thousand ostraca, which accounts for the existence of an industry based on ceramic recycling, especially amphorae.²²³ Among the documents one finds letters, reports, lists of guard duties, written orders, receipts, etc.²²⁴ The material from Wadi Fawakhir and Pselchis stands out through the multitude of letters illustrating the commercial ventures of the soldiers mainly with the purpose of acquiring foodstuffs.²²⁵

The vexillation fort at Gholaiia was established in AD 201, its garrison consisted of a detachment of the Legio III Augusta and a *numerus* type unit.²²⁶ A total of 146 ostraca were discovered here in 1967–76, dating to the AD 250s.²²⁷ The importance of the assemblage from Gholaiia is due to the fact that the majority of the documents, i.e. 117, were discovered in the chambers from the southern wing of the *principia*, thus coming from the *tabularium* of the fort.²²⁸ Unfortunately however, the archive is far from being complete, which is understandable considering that the fort was abandoned in an organized fashion, unlike Dura-Europos.²²⁹ In terms of their content, the ostraca from Gholaiia comprise of: morning reports, working rosters, accounting records, personal letters, etc.²³⁰

2.3. The military records

Our current knowledge of the internal administrative mechanism of the 1st–3rd century AD Roman military bases does not allow a detailed reconstruction of the bureaucratic material of the *tabularia* within the forts and fortresses. The textual evidence which has survived indicates

²²⁰ Speidel 1996, 85.

²²¹ Maxfield 2003, 153–154, 156.

²²² Alston 1995, 98.

²²³ Maxfield 2003, 154.

²²⁴ Maxfield 2003, 156.

²²⁵ Alston 1995, 97–98.

²²⁶ Marichal 1979, 436.

²²⁷ Adams 1999, 109

²²⁸ Marichal 1979, 436.

²²⁹ Marichal 1979, 438.

²³⁰ Marichal 1992, *passim*.

a complex administrative machinery that produced a high quantity and a wide range of official records which at this point seem to indicate a certain level of uniformity within military bases across the different regions of the Empire. It is important to underline that a complete *tabularium* is yet to be discovered. The main types of official military records include: 1) working rosters, 2) strength reports or *pridiana*, 3) duty rosters, and the 4) morning reports or *renuntia*, as well as a wide range of minor documents such as leave requests and accounting records, among others.

1) The so-called ‘working rosters’ include lists of the troops signalling both temporary and permanent changes in their composition, and were meant primarily to provide an account of the available personnel and equipment at any one time.²³¹ These registers were constantly being modified in keeping with the changes in the composition of the troops, as illustrated by the multitude of modifications and annotations within the texts, and the presence of multiple handwritings. The names of the soldiers were grouped in *centuriae*, arranged according to their rank and date of enrolment.²³² Few complete working rosters are hitherto known, the largest assemblage coming from Dura-Europos (RMR 1–4) dated to the first quarter of the 3rd century, while one such document was issued by the Cohors I Tungrorum in Vindolanda (TV II, 154) and is dated to AD 90. Of the 752 troops listed by the respective document, 456 were either absent from the fort or incapacitated by some medical condition. The garrison was thus reduced to 296 men, with only one centurion.²³³ The text also specifies that a detachment of 337 soldiers with two centurions was transferred to the nearby fort of Coria/Corbridge, with no clear specification of their mission, while forty-six soldiers were enrolled in the governor’s guard (*singulares*), a further number of soldiers suffering from an eye condition (*lippitudo*).²³⁴

2) The annual (or perhaps biannual) strength reports (*pridiana*) were admittedly presented to the governor probably at the end of each year, although there is some contradiction in the documents regarding the period and the number of reports drawn up over the period of a year.²³⁵ As mentioned above, only two such documents are known, both from Egypt (see above): the *pridianum* of Cohors I Augusta Lusitanorum Equitata of AD 156 (RMR 64), and that of the Cohors I Hispanorum Veterana of AD 105 (RMR 63). According to RMR 63, a number of soldiers from the latter unit, which was stationed in Lower Moesia in the wake of the Second Dacian War,²³⁶ were detached to Gaul for the procurement of clothes and foodstuffs, others to the mines of Dardania, while other contingents were sent to Buridava and Piroboridava.²³⁷

3) The so-called ‘duty rosters’ comprise registers of the troops together with specific duties of each soldier.²³⁸ The most detailed duty roster was discovered in Egypt, belonging to a *centuria* of the Legio III Cyrenaica and covering a period of ten days in AD 87 (RMR 9).²³⁹ Of the forty soldiers mentioned by the text, accounting probably for half or perhaps a third of a *centuria* in the respective legion, nine were away from the base, while others were also preparing for external missions.²⁴⁰ Most of the entries refer to guard duty both inside and outside the fortress, in addi-

²³¹ Fink 1971, 9.

²³² Fink 1971, 10.

²³³ Birley 2002a, 77.

²³⁴ Birley 2002a, 77–79.

²³⁵ Fink 1942, 71; contra Gilliam 1986, 270.

²³⁶ Fink 1958, 102, 114–116.

²³⁷ Davies 1974, 304; Watson 1974, 494–495.

²³⁸ Fink 1971, 106–114.

²³⁹ Davies 1974, 307, fig. B; Alston 1995, 96.

²⁴⁰ Alston 1995, 97.

tion to various tasks at the baths and the weapons storehouse (RMR 9).²⁴¹ Richard Alston pointed out the fact that over 10% of the headings are empty, suggesting that soldiers were free of official duties during the respective days.²⁴² The impression we get from these documents is that soldiers enjoyed perhaps more free time than previously believed, and the most frequent obligation was guard duty. The registers from Dura-Europos (RMR 12–19) indicate that around 25% of the soldiers were assigned to guard duty simultaneously.²⁴³ Furthermore, according to a duty roster from Vindolanda (TV II, 155), 343 troops were commissioned to activities within the workshops of the fort (*fabrica*).²⁴⁴ Among them twelve were leather-workers or shoemakers (*sutores*), eighteen were builders working on the bath-house (*structores*), others were casting lead (*plumbum*), or working on the hospital (*valetudinarium*), and at the kilns.²⁴⁵

4) The *renuntia* or ‘morning reports’ were allegedly part of the headquarters’ system of control which ensured the coherent following through of the garrison’s daily activities. These reports were drawn up on a daily basis by the second-in-command of every *centuria*, i.e. the *optiones*.²⁴⁶ The largest assemblage of *renuntia* comes from Vindolanda with thirty-five such texts belonging to the Batavian unit, among them one being intact (TV III, 574).²⁴⁷

2.4. Garrison life based on the sub-literary record

Probably the major limitation of analysing military everyday life based on sub-literary evidence is the overrepresentation of hierarchically imposed official activities in conjuncture with the underrepresentation of how the troops spent their time off duty. As mentioned above, the duty rosters suggest that soldiers had more free time than previously thought, however this part of their lives was not recorded in the official documents and sadly is usually not present in their personal correspondence either. It is hardly surprising then that out of the thirty-three pages of Roy W. Davies’ ground-breaking study only two actually deal with the personal life of the soldiers.²⁴⁸ Still, the personal documents illustrating instances of the soldiers’ social life and most often their commercial dealings aimed at procuring personal provisions remain valuable sources of information with regard to the more intimate aspects of soldiers’ lives.

The first official documents in which any individual recruit featured were the recommendation letters (*litterae commenditiciae*), which seem to have been compulsory according to the standard enrolment procedures.²⁴⁹ Examples of such letters come from Egypt and from Vindolanda.²⁵⁰ The next step for the future soldier was the juridical and medical assessment called *probatio*, meant to determine whether the recruit was apt for enrolment from both a legal and a medical point of view.²⁵¹ Unfortunately no official record of this procedure has survived, all data referring to it coming from indirect sources.²⁵² Once enrolled in the unit, the new recruit’s name was entered in the working roster, which was the main source of the periodic official strength report or *prid-*

²⁴¹ Davies 1974, fig. B.

²⁴² Alston 1995, 97.

²⁴³ Davies 1974, 320.

²⁴⁴ Bowman 1994, 38; Birley 2002a, 90.

²⁴⁵ Birley 2002a, 90.

²⁴⁶ Birley 2002a, 80.

²⁴⁷ Bowman 1994, 60; Birley 2002a, 80–81, fig. 53.

²⁴⁸ Davies 1974, 332–333.

²⁴⁹ Watson 1974, 496; Alston 1995, 160.

²⁵⁰ Watson 1974, 496; Alston 1995, 137; Birley 2002a, 85–86.

²⁵¹ Watson 1974, 496–497.

²⁵² Watson 1974, 497.

ianum.²⁵³ The daily tasks of the soldiers were established in advance over a period of several days and recorded in the duty rosters. The ‘morning reports’ from Dura-Europos (RMR 47–57) indicate the succession of events which marked the commencement of the daily activities. According to the respective sources, the day started with a general parade and continued with the inspection of the troops and the reading of the daily orders and watchword. This was followed by the naming of the soldiers who would take part in missions outside the fort, the gathering concluding with the taking of the oaths.²⁵⁴

As mentioned above, a considerable part of the soldiers received assignments which involved leaving their base for a certain period of time, resulting in the temporary, sometimes dramatic decrease in the strength of the garrison (see above). Probably the most spectacular instance recorded by the texts, is the case of the group of soldiers from the Cohors I Hispanorum Veterana stationed in Lower Moesia sent to Gaul with the purpose of procuring clothes and food provision for the unit (see above). Furthermore, the textual record suggests that soldiers frequently requested leave of absence, which involved handing in a written request called *commeatus*.²⁵⁵ As many as twelve such documents were discovered in Vindolanda consisting of standard short texts mentioning the destination and sometimes the purpose of the leave (see TV II, 176).²⁵⁶ It was noted that the handwriting was different in each case, suggesting that perhaps the soldiers themselves drew up the requests rather than the clerks of the unit.²⁵⁷ Similar documents, although in a much more standardized variant were discovered in Egypt.²⁵⁸

With regard to the question of supply, the Vindolanda writing-tablets and the papyri from Egypt show the soldiers individually procuring their personal provisions from various suppliers.²⁵⁹ Numerous contracts and letters account for these transactions. The longest and most complete text of this sort (TV II, 343) features a merchant called Octavius who informs his business partner, a soldier called Candidus of the evolution of their enterprise and requests urgent payment for the goods previously delivered.²⁶⁰ In other cases these transactions were admittedly done through the unit’s headquarters, the expenses being extracted from the soldiers’ pay, as it was probably common in the case of the military equipment and the daily food rations. Numerous accounting documents from Vindolanda contain lists of goods ordered by the soldiers together with the situation of the payments.²⁶¹ The existence of such centralized records indicates that the fort’s headquarters was actively involved in these transactions aimed at the procurement of various goods to individual soldiers, including clothes, foodstuffs (pork, chevon, and salt), beer, hobnails, etc.²⁶² A letter sent by a centurion to Flavius Cerialis, the commander of the Batavian unit indicates that a large consignment of clothes for the soldiers was ordered from the continent.²⁶³ One particular accounting document from Vindolanda contains a heading entitled *reditus castelli*, i.e. the incomes of the fort, which suggests that military bases could generate profit probably from the marketing of their surplus resources, either food provisions or perhaps the products of their own workshops.²⁶⁴

With respect to the question of military diet, numerous texts from Vindolanda refer both to the

²⁵³ Watson 1974, 500.

²⁵⁴ Davies 1974, 314.

²⁵⁵ Bowman 1994, 39.

²⁵⁶ Birley 2002a, 85.

²⁵⁷ Bowman 1994, 88.

²⁵⁸ Bowman 1994, 88.

²⁵⁹ Alston 1995, 97–98; Birley 1997, 275; Birley 2002a, 114–120.

²⁶⁰ Birley 2002a, 114–116, fig. 82.

²⁶¹ Birley 2002a, 101–105.

²⁶² Bowman 1994, 41; Birley 1997, 278.

²⁶³ Birley 1997, 278; Birley 2002a, 101.

²⁶⁴ Bowman 1994, 40–41; Birley 1997, 274.

situation in the *praetorium* and that of the barracks, thus providing the possibility of comparison between the two environments from this point of view.²⁶⁵ Furthermore, a large group of the said tablets contain valuable information regarding the presence of civilians in the fort, whether members of the officers' and soldiers' families, slaves or merchants, usually referred to in the literature as 'camp followers'.²⁶⁶ The same Vindolanda tablets have drawn attention to the powerful spirit of camaraderie between the soldiers illustrated by the designation *frater* (*fratre*) which inspired the title of Anthony R. Birley's book *Vindolanda: A band of brothers* (2002).

²⁶⁵ Bowman 1994, 65–70.

²⁶⁶ Bowman 1994, 56.

3. The auxiliary fort at Buciumi. General overview and research history

The auxiliary fort at Buciumi (Hu: Vármező) is part of Roman Dacia's north-western Limes segment along with the similarly sized bases at Bologa, Sutoru, Românași, Romita, Tihău, and the much larger Porolissum/Moigrad, from where the defence of this frontier portion was presumably coordinated (Pl. 1). The line of forts became part of Dacia Porolissensis during the early-Hadrianic period. The fort is situated on a plateau, north of the present-day village at the confluence of two streams.²⁶⁷ The Romanian names of the plateau 'Grădiște' and 'Cetate' as well as the Hungarian designation of the village itself 'Vármező' (Ge: Burgfeld) suggest the presence of a fortification in the respective location. According to the pioneer archaeologist Károly Torma (1829–1897) the ruins were still visible above ground at the middle of the 19th century.²⁶⁸ The civilian settlement (*vicus*) was identified on the north-eastern side of the fort, but was never effectively researched. South-east of the fort, at a distance of about 150–200 m, on the same plateau, the remains of the fort's bath-house was identified by the same Károly Torma, his hypothesis being corroborated by a survey carried out in 1966.²⁶⁹

There is no clear epigraphic indication regarding the Roman name of the site, although based on the recent analysis of Ptolemy's Geography, it would appear that the name was Docidava.²⁷⁰ Based on the evidence provided by stamp tiles, stone inscription fragments and the inscribed bronze property labels (*tesserae militares*), several attempts were made to establish the list and the order of the troops stationed here throughout the existence of the fort.²⁷¹ A complete and satisfactory scheme is however yet to be put forward. It was considered for a long time that the first unit to station here was the Cohors I Augusta Ituraeorum between 106 and 114 AD.²⁷² The hypothesis based on a number of tile stamps with the inscription *Coh(ortis) I Aug(ustae)*,²⁷³ and an inconclusive inscription fragment,²⁷⁴ has been since branded as uncertain.²⁷⁵ The unit which undoubtedly left the most marked traces, was Cohors II Augusta Nervia Brittonum, attested by two inscriptions honouring Emperor Caracalla.²⁷⁶ The discovery of the two inscriptions (the first one in 1948) also helped elucidate the name of the unit present on a number of tiles, which was previously misinterpreted by Torma.²⁷⁷ The respective unit was founded in the Neronian period, its name possibly

²⁶⁷ The first description of the site in Torma 1863, 11–12; for further information see Chirilă et al. 1972, 7–9.

²⁶⁸ Torma 1863, 11–12.

²⁶⁹ Gudea 1997b, 63–64.

²⁷⁰ Nemeti 2014, 66.

²⁷¹ Russu 1959, 315–316; Chirilă et al. 1972, 117–118; Gudea 1997b, 24–27, 31–34, 52–53; Marcu 2009, 52–53.

²⁷² Gudea 1997b, 24–25.

²⁷³ IDR Appendix I, XVII/1–2, 4–5.

²⁷⁴ Chirilă et al. 1972, 117, nr. 11, pl. CXXXIX; Gudea 1997b, 24–25.

²⁷⁵ Marcu 2009, 52.

²⁷⁶ Chirilă et al. 1972, 115–116.

²⁷⁷ Torma 1863, 12; Torma 1880, 127; Russu 1959, 211–216.

suggesting that the soldiers were recruited from among the Britons of Nervia Glevum/Gloucester, and before arriving to Buciumi, it seems to have been stationed in Lower Pannonia.²⁷⁸

A number of rectangular and disc-shaped bronze labels (*tesserae militares*) with dot-punched inscriptions²⁷⁹ reveal the names of further three military units that might have stationed at any one time in the fort, or more likely, have dispatched vexillations or delegations temporarily to Buciumi.²⁸⁰ Without going into the epigraphic and onomastic details of the inscriptions, which are yet to be fully clarified, the following units were identified: Cohors I Ulpia Brittonum, or Cohors I Britannica²⁸¹ (abbreviate as: CIB), Cohors I Flavia Hispanorum,²⁸² and Cohors I Hispanorum.²⁸³ Even so, the only certainty seems to be the extended presence of Cohors II Augusta Nervia Brittonum, which probably ended only with the definitive withdrawal of the troops from the fort. The aforementioned written evidence attesting further units linked to the fort seems to illustrate the high level of mobility of soldiers and vexillations between forts, a phenomenon already outlined by the Vindolanda writing-tablets (see above).

The earliest preserved written information concerning the Roman ruins from Buciumi dates to the 17th century,²⁸⁴ however the first assessment of the fort in the context of Dacia's defensive system came about with Károly Torma's survey of the Limes during the early 1860s.²⁸⁵ Subsequently, two inscriptions were discovered on the site: CIL III 842 and CIL III 7645, the latter being a votive altar dedicated to Iuppiter Optimus Maximus Dolichenianus (IOMD) by a *beneficiarius consularis* named P. Iulius Firminus.²⁸⁶ The discovery in 1948 of the inscription honouring Emperor Caracalla (see above) redirected the attention of the archaeological community on the fort at Buciumi.²⁸⁷

Systematic yearly archaeological surveys commenced in 1963, lasting until 1976.²⁸⁸ The results of the campaigns finalized in 1970 were published in a monograph two years later.²⁸⁹ The findings of the latter period of investigations were not published in a detailed monographic fashion, but in a series of separate reports focusing on the main architectural structures of the fort,²⁹⁰ as well as certain finds' categories.²⁹¹

The excavations carried out between 1963 and 1970 focused on the investigation of the fort's defences, the buildings of the central range (*latera praetorii*) and of the *praetentura* (Pl. 2). Barracks nos. 4 and 5 from the *praetentura sinistra* and the headquarters building (*principia*) were excavated integrally (Figure 3), while the commander's residence (*praetorium*) consisting of buildings C3 and C4, as well as buildings C5 and C6 from the central range, buildings C1 and C2 from the *praetentura*, in addition to barracks nos. 1, 2, and 3, were partially excavated.²⁹² The *retentura* of the fort was researched only through a small number of evaluation trenches.

²⁷⁸ Spaul 2000, 201.

²⁷⁹ Gudea 1982.

²⁸⁰ For a recent reevaluation of the material see Piso 2015, 209–212.

²⁸¹ Gudea 1982, fig. 5/4; Gudea 1997b, 26; Marcu 2009, 52.

²⁸² Gudea 1982, 54, 1.1; 55, 7.1.

²⁸³ Gudea 1982, 55, 5.1.

²⁸⁴ Russu 1959, 308, footnote 3.

²⁸⁵ Torma 1863, 11–12; Torma 1880, 75, 116, 119, 127.

²⁸⁶ Torma 1879, 90, no. 10.

²⁸⁷ Russu 1959.

²⁸⁸ Chirilă et al. 1972, 5–6, 11–12; Gudea 1997b, 13–15.

²⁸⁹ Chirilă et al. 1972.

²⁹⁰ Landes 1979; Landes/Gudea 1980; Gudea/Landes 1981; Landes-Gyéánt/Gudea 1984; Gudea 1997b, 23.

²⁹¹ Gudea/Matei 1981 (the keys); Gudea 1982 and Gudea 1984 (the *tesserae militares*); Gudea/Bajusz 1991 (the bone hairpins); Gudea/Bajusz 1992 (the medical instruments); Gudea/Cociş 1995 (the brooches); Gudea/Cosma 2003 and Gudea/Cosma 2008 (the lamps); Găzdac/Pripon 2012 (the coins); Petruţ 2014; Petruţ 2015; Dana/Petruţ 2015 (the pottery finds).

²⁹² Macrea et al. 1969, 152–154; Chirilă et al. 1972, 31.

The research undertaken over the next years (1971–76) focused on the finalization of the excavations from the *praetentura* (Figure 3), where further two barracks were fully uncovered (nos. 2 and 4), and to a lesser extent on the research of the *retentura*, which revealed the number and orientation of the barracks from this part of the fort, i.e. the existence of two double- (nos. 7 and 9) and two simple barracks (nos. 8 and 10).²⁹³

Following the end of the systematic research campaigns, archaeological investigations were carried out on two occasions in the fort, in 1997, owing to restoration work in the headquarters building,²⁹⁴ and later in 2015 prior to the rebuilding of the fort's defences. The recent excavations uncovered some of the fort's gates, towers, and a part of the interior road network in front of the *principia*.²⁹⁵ According to the published report, the investigations revealed a large storage pit inside one of the towers of the *porta principalis sinistra*, and led to the discovery of a large hitherto unpublished inscription panel mentioning the same unit as the two previous inscriptions (Cohors II Augusta Nervia Brittonum) in the area in front of the headquarters building.²⁹⁶ In addition to this, two funerary relief fragments, probably reused as construction material for the reparation of various masonry structures in the fort were also discovered.²⁹⁷ Furthermore, so-called high precision micro topographical surveys were carried out on the site in 2014, which revealed a well-outlined building with a rectangular plan not far from the rear gate of the fort (*porta decumana*), which could in fact be the bath-house of the garrison.²⁹⁸

According to the excavators, the fort had two main construction/habitation phases, an initial earth and timber phase divided into two sub-phases (1a and 1b), followed by a stone phase (2). The fort ascribed to the last phase, built during the early stages of the 3rd century, measured 167 × 134 m, resulting in a surface of roughly 2.23 hectares.²⁹⁹ Admittedly, the perimeter and the overall size of the fort suffered only minor changes following its reconstruction in stone. The general layout of the barracks remained largely the same throughout the fort's existence, with six barracks in the *praetentura* (two double and four simple structures), and four barracks in the *retentura* (two double and two simple structures), parallel to the *via principalis* (Pl. 3).

The double barracks measured around 50 × 19 m, while the simple ones were roughly of 50 × 9 m.³⁰⁰ Initially, barracks nos. 1 and 2 appear to correspond to Davison type F, whereby a narrow corridor ran through the middle of the building separating the *papiliones* and *armae*, each of these having a width of around 2–2.5 m,³⁰¹ both with a 2 m wide portico. A striking feature is represented by the different plans of the two adjoined barracks making up barracks no. 2.³⁰² During phase 1b, which commenced in the late-Trajanic/early-Hadrianic period,³⁰³ their plan was altered. They were transformed in what Nicolae Gudea identifies as Davison type A (though the *contubernia* sized 3.5 × 3.5 m seem undivided), with 2–2.5 m porticoes in front.³⁰⁴ When the fort was rebuilt in stone, probably at the beginning of the 3rd century, it was assumed that little changed in the case of the barracks, their internal plan remaining largely the same. Apparently however, the pillars of the porticoes were replaced, the new ones being placed on stone walls surrounding the

²⁹³ Gudea 1997b, 23.

²⁹⁴ Timoc/Bejinariu 2000, 345.

²⁹⁵ Bejinariu et al. 2016, 125.

²⁹⁶ Bejinariu et al. 2016, 125.

²⁹⁷ Zăgreanu/Pop 2015.

²⁹⁸ Opreanu/Lăzărescu 2016, 64–67, Fig. 20.

²⁹⁹ Chirilă et al. 1972, 13–14.

³⁰⁰ Gudea 1997b, 22–23.

³⁰¹ Gudea 1997b, 30, fig. 19/1.a, 2.a; Davison 1989, 72–73, fig. A/F.

³⁰² Marcu 2009, 44–46.

³⁰³ Găzdac/Pripon 2012, 1.

³⁰⁴ Gudea 1997b, 28–30, fig. 19/1.b, 2.b; see Davison 1989, 75 for type G with portico, fig. A/A, G.

buildings, an arrangement that must have led to a modified roof structure.³⁰⁵ It was furthermore asserted that barracks nos. 4 and 5 might have not functioned as living quarters, but perhaps as storehouse or hospital, respectively a *fabrica*,³⁰⁶ although, based on the existing data, this seems quite unlikely.³⁰⁷ The argument in the case of barracks no. 5, whereby the large numbers of crucibles, tools, and slag, as well as the presence of several hearths indicates that we are dealing with a workshop,³⁰⁸ is far from being undisputable, as similar finds are yielded by the other barracks as well,³⁰⁹ while the distortion could be caused by the fact that the structure known as barracks no. 5 produced probably the highest amount of finds among all of the fort's structures, including also a large number of terra sigillata vessels (see below). David P. Davison has noted, based on evidence from Britain, that the large number of metalworking tools and production implements in general suggests the existence of small repair workshops within the barracks (usually the size of a single *contubernium*), thus making the presence of a central *fabrica* dispensable.³¹⁰

A graphical reconstruction was proposed for the last phase of barracks nos. 1 and 2. According to it, the double barracks had three rows of rooms, the middle row (presumably a large undivided hall) tentatively considered a storage space, illuminated through windows on the lateral sides of the building.³¹¹ It seems that in each phase the barracks were built of wattle and daub and the double pitch roofs were covered with tiles.³¹² However, it should be noted that there are doubts about the aforementioned stone walls surrounding them. These might actually be stone sill walls which supported the rebuilt wooden structures, and not pillars.³¹³

Structure	First period of research (1963–1970)	Second period of research (1971–1976)
Barracks no. 1	–	1972 – the plan of the structure revealed 1973 – excavated completely
Barracks no.2	1965 – the north-western half excavated completely	1971–1973 – the south-eastern half excavated completely
Barracks no.4	1970 – excavated completely	–
Barracks no.5	1967– 1969 – excavated completely	–

Figure 3. The main stages of the barracks' research history in the auxiliary fort at Buciumi

³⁰⁵ Chirilă et al. 1972, 21; Gudea 1997b, 50–51, fig. 19/1.c, 2.c.

³⁰⁶ Gudea 1997b, 29.

³⁰⁷ Marcu 2009, 48–51.

³⁰⁸ Chirilă et al. 1972, 57–58, 77–86; see also Landes-Gyemant/Gudea 2001, 147.

³⁰⁹ Petruț 2013, 190–191.

³¹⁰ Davison 1989, 242.

³¹¹ Landes-Gyemant/Gudea 2001, 151, Abb. 19.

³¹² Gudea 1997b, 23, 28–29, 50; Landes-Gyemant/Gudea 2001, 151.

³¹³ Marcu 2009, 46, 50.

4. The pottery assemblages from the barracks

4.1. Methodology and terminology

The current chapter is aimed at presenting the hitherto unpublished pottery vessel assemblages unearthed during the latter part of the excavations in the Roman fort at Buciumi (1971–76). The ultimate goal is that the data obtained from the pottery analysis in correlation with the review of the research from Chapter 1 and the discussion of the sub-literary record from Chapter 2 can be translated into aspects of military everyday life in the said fort. The results will be outlined in the final part of the current section as well as the conclusions chapter (Chapter 6) following its correlation with the analysis of the small finds included in the next section (Chapter 5). The material under scrutiny is comprised of the pottery vessels discovered during the aforementioned period (for the composition of the assemblage see Figure 4). The material will be discussed according to the research-particularities inherent to their informational potential, with a catalogue-style individual description of the artefacts given only in the case of the imported vessels, i.e. terra sigillata and amphorae, due to the ambiguity often involved in the determination of their origin and dating. The greater part of the pottery assemblages will be presented in the shape of quantified data, consisting of a catalogue of types and the accompanying statistics. The methodology of Roman pottery analysis has evolved considerably over the last few decades, incorporating ever more complex and integrated approaches. Nevertheless, a single, universally available approach is yet to emerge, the choice of method being determined by a number of factors, such as: the character and state of conservation of the material, the contextual data available or the lack of it, and the state of the art with regard to Roman pottery in the region or the province.

The current analysis consists of an integrated approach centred on three main criteria of investigation and classification: 1) the morphological or ‘typological’ classification, 2) technological classification based on the macroscopic assessment of the fabrics-groups, and 3) the functional evaluation. It is self-understood that there is a great degree of overlap between the three aspects,³¹⁴ and indeed the grouping of the material into ‘tableware’, ‘cookware’ and ‘utilitarian ware’ in the first section already comprises a basic functional assertion, however this analysis is meant to cover the question of primary functionality, based mainly on morphological and technological criteria, i.e. the shape and the fabrics of the vessel, as well as traces of use, while instances of potential secondary functionality will be addressed in the third section (‘functional evaluation’). Given the highly fragmentary nature of the material, consisting usually of small-sized sherds, a proper morphological classification is beyond the reach of the present study, therefore only the rim fragments can be taken into account as they give a sense of the vessels’ original shape. Exception from this principle will of course be made in the case of terra sigillata and amphora fragments which will be classified according to their universally recognized form codes: Dragendorff (Drag.), Déchelette (Déch.), Ritterling, Curle, Ludowici (Lud.), Dressel, etc.

³¹⁴ Rice 1987, 207; Orton et al. 1993, *passim*.

The discussion of the technological aspects focuses on the fabrics of the vessels. The underlying assumption is that the choice of fabrics and of surface treatment (colour-coating, glazing, or burnishing) is the main indicator of the production process, and in conjunction with the shapes employed, it provides the basis for the evaluation of the primary functionality.³¹⁵

Functionality is the final, and probably the most essential aspect discussed, as it enables a connection between the artefacts and certain activities which had a role in defining the day-to-day life in and around the barracks. The aim is to obtain a somewhat comprehensive picture related to the distribution of functional categories within the assemblage. The quantified data resulting from the analysis of the morphological, technological and functional aspects will be expressed statistically through a series of charts.

As mentioned above, the approach adopted in the finds analysis is largely determined by the contextual data available. Given the fact that the material under scrutiny here resulted from archaeological investigations carried out over forty years ago, one must take into account the serious limitations of on-site finds' registration and implicitly of the accuracy and resolution of the contextual data. For the moment two major shortcomings will be mentioned. First of all, due to the lack of accurate spatial information, precise distribution maps are impossible to obtain. Even so, certain differences in the distribution of some categories between the so-called centurion's quarter and the quarters of the men could be detected (see below). The second major deficiency concerns the failure of the excavators to interpret and describe the contexts from which the finds were retrieved, meaning that in effect the material is unstratified. One of the consequences is that it is impossible to distinguish the material discarded or lost inside the barracks from the 'residual' and redeposited finds brought from outside during the periodical refurbishment of the clay floors. At any rate, this so-called 'residual' material was probably originally also used in the barracks, as there is no immediate need to doubt that the soil used for the refurbishment of the floors was in fact brought from the vicinity of the barracks where it could get mixed with rubbish (e.g. pottery sherds) disposed from the barracks. Indeed, the extremely fragmentary state which characterises the bulk of the material suggests that the lion's share of pottery finds might come from these layers of floor renovation.

Given the implications of terminology in Roman material studies in general and pottery studies in particular, the basic principles in designating the vessel types should be briefly addressed here. The terminology employed in Roman pottery studies is characterized by the occasionally ambivalent duality of modern and antique terms. The comprehensive study by Werner Hilgers has shed light on the lack of uniformity and consensus in the designation of vessel types in the literary sources, the number of terms attested by the textual evidence grossly outweighing the actual vessel repertory used in the respective periods.³¹⁶ There are comparatively few cases in which antique designations can be precisely correlated with archaeologically attested vessel types or shapes, e.g.: *turibulum*, *amphora*, *dolium*, *operculum*, *atramentarium*, *cortina*, *situla*, *infundibulum*, *lanx*, *mortarium*, *simpulum*.³¹⁷ These are generally accepted in the archaeological literature making their use unavoidable. To this, one can add the vessel names from the potter's records discovered in La Graufesenque: *panna*, *calix*, *catinus*, *catillus*, *paropsis*, *acetabulum*, and *kantharus*.³¹⁸ Still we have no way of knowing whether any of these names were universally recognized throughout larger parts of the Empire. For this reason pottery studies rely heavily on the use of contemporary terminology for the designation of vessels, which usually also implies a functional assessment of the respective vessel shape.³¹⁹ In some cases the uncritical use of certain Latin terms led to the

³¹⁵ Rice 1987, 207.

³¹⁶ Hilgers 1969, *passim*; Mustața 2011, 233–234.

³¹⁷ Mustața 2011, 233, note 5.

³¹⁸ Gabler 2006, 35–36.

³¹⁹ Webster 1976, 17; Rice 1987, 209–210.

perpetuation of incorrect terminology over long periods, the most notorious case being that of the so-called ‘*paterae* with handles’, which are in fact components of the hand-washing set (‘*Kanne und Griffschale*’).³²⁰ Generally a highly critical stance is required when labelling artefacts with their supposed original name, as it can lead to circular arguments regarding their function.³²¹ As noted by Prudence M. Rice, the modern terms are often vague, but still they offer a descriptive framework which incorporates information regarding the morphology and the primary functionality of the vessels.³²²

The use of modern terminology can potentially be improved by additionally adopting a set of precise, technical criteria of classification. British archaeologist Graham Webster devised over four decades ago a system based on the proportions between various dimensions of the vessels, especially the diameter of the mouth opening and the base, the maximum diameter of the vessel’s body and its height.³²³ The nature of Roman provincial pottery however brought about the need to correlate these data with further morphological features of the vessels, e.g. the rim shape, the body shape, or the type of the base.³²⁴

4.2. The classification of the vessels (form and fabrics)

The choice of the classification system for the local pottery vessels (i.e. excluding the imported wares such as the sigillata and amphorae) was determined by two aspects. The first one is related to the fact that the classifications of Roman provincial pottery based on morphological similarities, the so-called ‘type series’, do not have universal applicability.³²⁵ The main reason for this consists in the variation between the regional production output and the occasional influence of pre-Roman manufacturing traditions, as well as the proximity of markets in the Barbaricum (such as in the case of Porolissum). David P.S. Peacock has described no less than eight production modes for Roman provincial pottery ranging from the most simple to the most complex.³²⁶ While an auxiliary fort can be described in archaeological terms as a consumption site, according to the current military supply model, the production centre which provided the bulk of pottery commodities was situated in the nearby *vicus*. Thus beyond the seemingly unitary nature of the pottery material found in Roman military bases, the assemblages are in fact quite diverse when looked at in detail. The second aspect refers to the physical features of the material under scrutiny here, namely its extremely fragmentary state of preservation. Moreover, the material was submitted to an ample process of selection, during which it was grouped into morphological categories (rim fragments, base fragments, handles, etc.) while the undecorated wall fragments were discarded. Needless to say, any attempt of proper quantification is futile.³²⁷

The classification based on the morphological features was restricted to the rim fragments, as these are the most suggestive parts of the vessels from an overall morphological and functional point of view.³²⁸ Base fragments and handles as well as the occasional wall fragments were excluded from the classification in order not to further distort the quantification by registering more fragments of the same vessels. The classification consists of three levels. The first one is primarily functional, assigning the fragments to three large functional categories: ‘tableware’, ‘cookware’, and ‘utilitarian

³²⁰ Nuber 1973, 102; see also Mustața 2017, 44–45.

³²¹ Giles 2012, 32, citing Allison 1999.

³²² Rice 1987, 210–211.

³²³ Webster 1976, 17–20; Rice 1987, 215–217; Opaît 1996, *passim*.

³²⁴ Rice 1987, 117–222; Orton et al. 1993, 155–162.

³²⁵ Orton et al. 1993, 153.

³²⁶ Peacock 1982, 6–11.

³²⁷ Orton et al. 1993, 166–181.

³²⁸ Rice 1987, 222–223.

ware' (see below) based on the correlation of the morphological features (primarily form) and the types of fabrics, based on the 'form + fabric = function' model. The underlying assumption is that cookwares were usually made of coarse fabrics in order to withstand the thermic shock that the vessels were subjected to, while tablewares were commonly made from fine fabrics. The so-called utilitarian wares displayed usually semi-fine fabrics (see below). The second level involves assigning the fragment to a general vessel type or class defined by specific shape parameters (bowl, carinated bowls, pot, dish, etc.). The types within the classes are differentiated on the morphological criteria specific to the structure of the rims, i.e. the axis (everted, inturned, horizontal, or vertical) and shape of the rim (cavetto, flange, etc.), shape and thickness of the lip (beaded, rounded, triangular, subangular), and the existence of grooves or reeding on the outside, or furrows for the fastening of the lid on the inside (lid-seating), as well as the existence of ridges or a flanges below the rim. Whenever possible and practical, reference will be made to the shapes published in the 1972 monograph, particularly in cases when intact vessels illustrated in the respective publication can help elucidate or better understand the forms discussed here.

Class codes:

Tableware	BO	bowls
	DI	dishes
	PL	platters
	BE	beakers
	CU	cups
Utilitarian ware	DO	<i>dolia</i> (including <i>seriae</i>)
	JA	jars
	FL	flagons
	JU	jugs
	MO	<i>mortaria</i>
	ST	strainers (cheese presses)
Cookware	PO	pots
	CA	casseroles (carinated bowls)
	PA	pans

The necessity of integrating the fabrics analysis in the classification of the vessels has gained wide acceptance over the last two or three decades since the pioneering work undertaken by David P.S. Peacock in the 1960s–70s.³²⁹ The macroscopic analysis, carried out usually with a low power optical microscope, focuses on the type of firing, the porosity, the texture of the fabric and the non-plastic inclusions (tempers) inside the ceramic fragments. Fabrics analysis is indicative with regard to two fundamental aspects of pottery studies, i.e. the origin and the functionality of the vessels. The two underlying principles behind these investigations are that the non-plastic inclusions, i.e. tempers or impurities present in the ceramic matrix, reflect the geological characteristics of the workshop's surroundings, but also the technical necessities imposed by the functionality of the respective vessels. Nonetheless it has to be pointed out that a certain type of fabric can feature in the products of several workshops which operate in a certain area, at the same time the products of one workshop can display a wide array of very different fabrics.³³⁰ Based on the porosity and the hardness of the ceramic bodies, furthermore the frequency, the dimensions, the form and distri-

³²⁹ Peacock 1977a, 21–33; Williams 1979, 73–76; Orton et al. 1993, 17–21.

³³⁰ Orton et al. 1993, 135.

bution of the non-plastic inclusions, the fabrics are grouped into three main categories: 1) fine, 2) semifine, and 3) coarse.³³¹ Accordingly, the fabrics codes consist of the following elements: 1) the type of firing (O = oxidized or R = reduced), 2) the structure and the texture of the matrix (F = fine, S = semifine, or C = coarse), and the individual number of each fabric type.

O	oxidized firing
R	reduced firing
F	fine fabric
S	semifine fabric
C	coarse fabric

The catalogue of the codes

OC 1

Oxidized coarse fabric, high granulation and porosity; the colour varies between pale orange and brick red; inclusions: frequent white and grey quartz (2–4 mm), occasional black quartz (3–4 mm), frequent mica dust, occasional fine calcite grains (1–2 mm).

Sample: pot rim (PO), inv. no. 415/1973. (Pl. 35).

OC 2

Oxidized coarse fabric, medium granulation and porosity; the colour is pale brick red; inclusions: frequent white and grey quartz (1–2 mm), occasional larger grains (up to 4 mm), frequent mica dust, occasional iron oxide grains (1–2 mm).

Sample: pot rim (PO), inv. no. 609/1973. (Pl. 35).

OC 3

Oxidized coarse fabric, low granulation, and medium porosity; the colour is dark brick red; inclusions: frequent mica dust, occasional calcite grains (1–2 mm), and occasional large grains of black quartz (up to 5 mm).

Sample: pot rim (PO), inv. no. 615/1973. (Pl. 35).

OC 4

Oxidized coarse fabric, low granulation, and medium porosity; the colour is intense brick red; inclusions: frequent mica dust, with occasional larger grains (up to 2mm), occasional calcite grains (up to 2mm), occasional white quartz (up to 2 mm).

Sample: casserole rim (CA), inv. no. 588/1973. (Pl. 35).

OC 5

Oxidized coarse fabric, high granularity and porosity; the colour is light brown; inclusions: frequent large white quartz grains (up to 5mm), occasional grey quartz (up to 2 mm), occasional mica dust and iron oxide grains.

Sample: pot lid (PO), inv. no. 269/1973. (Pl. 36).

OC 6

Oxidized coarse fabric, high granularity and medium porosity; the colour is light brown; inclusions: frequent iron oxide grains (up to 5 mm), frequent white and grey quartz (3–4 mm), occasional calcite

³³¹ Ionescu/Ghergari 2007, 436–437.

(up to 2 mm), occasional mica dust and larger mica grains (up to 2 mm), traces (voids) left by burnt out organic materials.

Sample: wheelthrown lamp, inv. no. 319. (Pl. 36).

OS 1

Oxidized semifine hard fabric; the colour is light brick red; inclusions: frequent mica dust, occasional grey and transparent quartz, occasional calcite (2–3 mm).

Sample: *dolium* rim (DO), inv. no. 376. (Pl. 36).

OS 2

Oxidized semifine fabric of medium porosity; the colour is coffee brown; inclusions: frequent mica dust, occasional grey quartz grains (2–3 mm).

Sample: *dolium* rim (DO), inv. no. 402/1973. (Pl. 36).

OS 3

Oxidized semifine, slightly porous fabric; the colour is pale orange; inclusions: frequent mica dust, occasional small calcite grains (up to 2 mm); occasional white, grey, and black quartz (up to 2 mm), occasional iron oxide grains.

Sample: jug rim (JU), inv. no. 406. (Pl. 37).

OS 4

Oxidized semifine (almost coarse) fabric of medium granularity and porosity; the colour is intense brick red; inclusions: frequent mica dust, occasional white quartz (3–5 mm), occasional calcite (1–2 mm).

Sample: jug rim (JU), inv. no. 429/1973. (Pl. 37).

OF 1

Oxidized fine, slightly porous fabric, usually encountered with the so-called ‘terra sigillata imitations’; the colour is brick red; inclusions: frequent mica dust, occasional iron oxide grains (1–2 mm), and occasional small calcite grains (1 mm).

Sample: bowl rim (BO), inv. no. 505/1973. (Pl. 37).

OF 2

Oxidized compact fine fabric with occasional medium-sized voids; the colour is dark coffee brown; inclusions: frequent mica dust, occasional small calcite grains.

Sample: bowl rim (BO), inv. no. 655/1973. (Pl. 37).

OF 3

Oxidized fine, slightly porous fabric; the colour is intense brick red; inclusions: frequent mica dust, occasional calcite (2–3 mm), and occasional small grey quartz grains.

Sample: bowl rim (BO), inv. no. 436/1973. (Pl. 38).

OF 4

Oxidized, slightly porous fine fabric, frequently encountered with the so-called ‘terra sigillata imitations’; the colour is light brick red; inclusions: frequent mica dust, frequent small calcite grains (1 mm), occasional quartz (1–2 mm), occasional small pyrite pellets.

Sample: dish rim (DI), inv. no 439/1973. (Pl. 38).

RC 1

Reduced coarse fabric of medium granularity and porosity; the colour is dark grey; inclusions: frequent calcite grains (2–4 mm), frequent mica dust, occasional iron oxide grains.

Sample: pot rim (PO), inv. no. 604/1973. (Pl. 38).

RC 2

Reduced coarse fabric, highly gritty and porous; the colour is dark coffee brown; inclusions: frequent large mica grains (2–3 mm), large calcite grains (3–4 mm), and frequent grey quartz.

Sample: pot rim (PO), inv. no. 647/1973. (Pl. 38).

RC 3

Reduced coarse fabric of medium granularity and porosity; the colour is grey; inclusions: frequent mica dust, occasional iron oxide grains, occasional grey quartz (2–3 mm), occasional calcite grains (2–3 mm).

Sample: pot rim (PO), inv. no. 615/1973. (Pl. 39).

RC 4

Reduced coarse, highly gritty and porous fabric; the colour is dark brown; inclusions: frequent white quartz (5–6 mm), frequent large mica grains (up to 2 mm), frequent calcite (2–4 mm).

Sample: pot rim (PO), inv. no. 429/1973. (Pl. 39).

RS 1

Reduced semifine fabric, medium granularity and porosity; the colour is brownish grey; inclusions: frequent mica dust; frequent grey quartz (1–3 mm), occasional calcite (1–2 mm).

Sample: casserole rim (CA), inv. no. 655/1973. (Pl. 39).

RS 2

Reduced semifine, slightly porous fabric; the colour is coffee brown; inclusions: frequent mica dust, occasional black quartz (2–3 mm).

Sample: *dolium* rim (DO), inv. no. 389/1973. (Pl. 39).

RF 1

Reduced compact fine fabric; the colour is dark coffee brown; inclusions: frequent mica dust, occasional small calcite grains.

Sample: jug rim (JU), inv. no. 421/1973. (Pl. 40).

RF 2

Reduced slightly porous fabric; the colour is light grey; inclusions: frequent mica dust, occasional iron oxide grains, occasional black quartz (1–2 mm).

Sample: bowl rim (BO), inv. no. 415/1973. (Pl. 40).

RF 3

Reduced compact fine fabric; the colour is coffee brown; inclusions: frequent mica dust, and occasional white and grey quartz (up to 2 mm).

Sample: terracotta figurine (see Chapter 5), inv. no. 161/1973. (Pl. 40).

Each pottery fragment was analysed with a low power binocular microscope ($\times 20$). All in all a number of twenty-three fabric types were identified and registered, among them fourteen oxidized fabrics, accounting for 72% of the vessels, while the remaining nine are the result of reduced firing, representing just below a third of the assemblage, i.e. 28% (Figure 5). With regard to the structure and granulation of the fabrics, the oxidized group is made up of 47% semifine fabrics, 26% coarse, and 27% fine fabrics (Figure 6). These figures are highly telling and will be analysed in Chapter

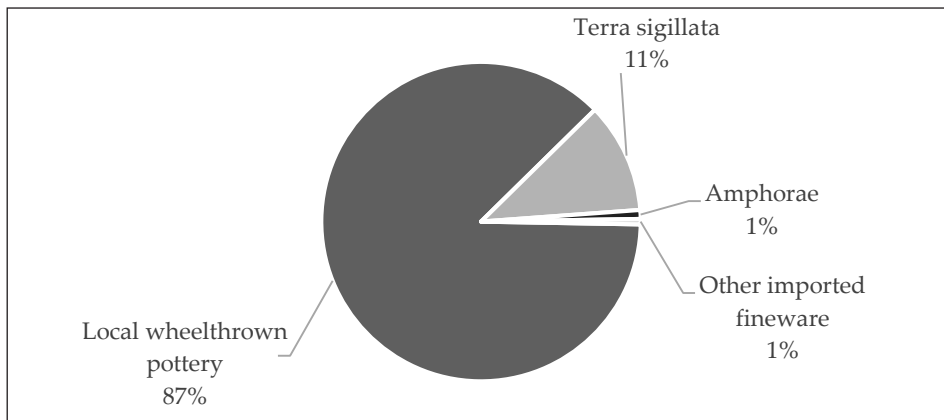

Figure 4. The distribution of the main groups of vessels within the assemblage.

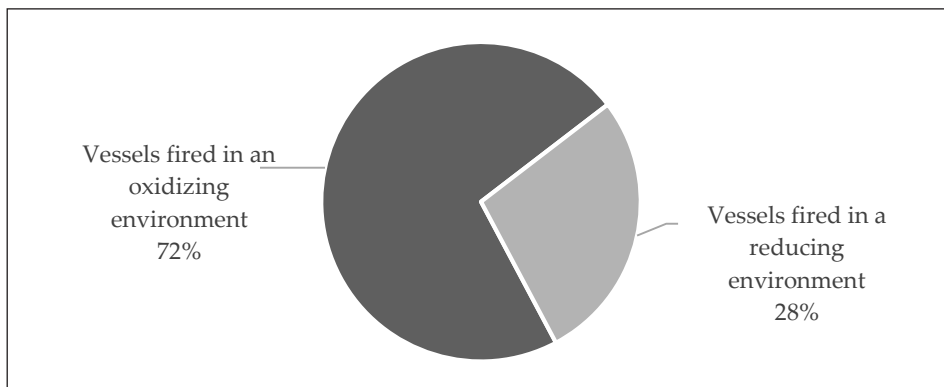

Figure 5. The distribution of the vessels based on the type of firing employed (oxidized wares and reduced wares).

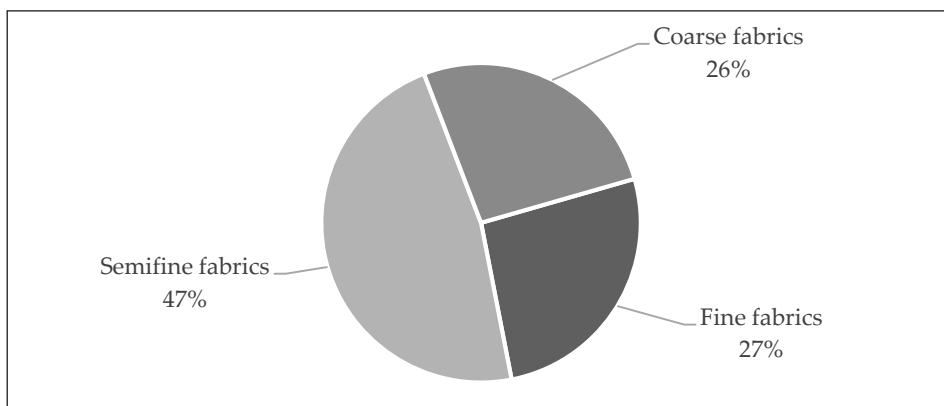

Figure 6. The distribution of the main fabrics categories within the group of oxidized wares.

4.3 (Functional aspects). At any rate, one can notice a clear correlation between oxidized firing and semifine and fine ceramic mixtures, which are preponderant among the tableware (Figure 8). The semifine fabrics of this group are overwhelmingly represented by vessels belonging to the utilitarian ware (Figure 9). With regard to the reduced fabrics, the situation is contrary: the category of coarse pottery comprises 57% of the fragments, while the group of fine and semifine vessels represent more or less equal shares of the remainder (Figure 7). The high proportion of coarse fabrics within this group is represented by vessels belonging to cookware (Figure 9).

It is safe to say that the function attributed to each vessel was decisive in determining the choice of fabrics employed by the potter (see above), and to a certain extent the type of firing. It is easy to deduce from the quantification that the tableware is mostly composed of fine fabrics, the utilitarian

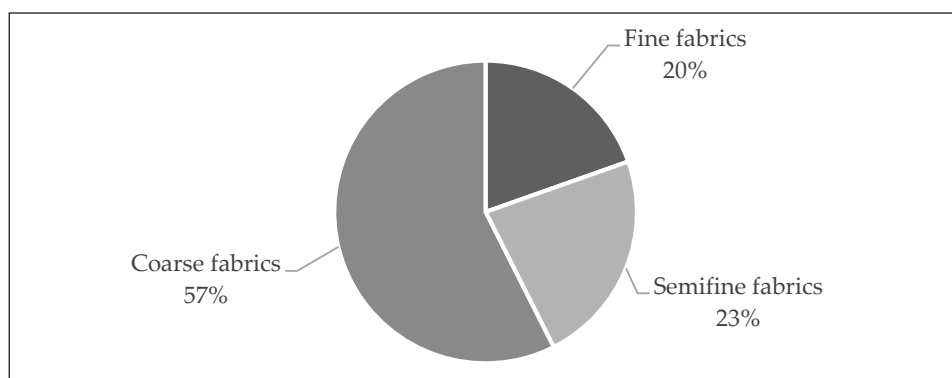

Figure 7. The distribution of the main fabrics categories within the group of reduced wares.

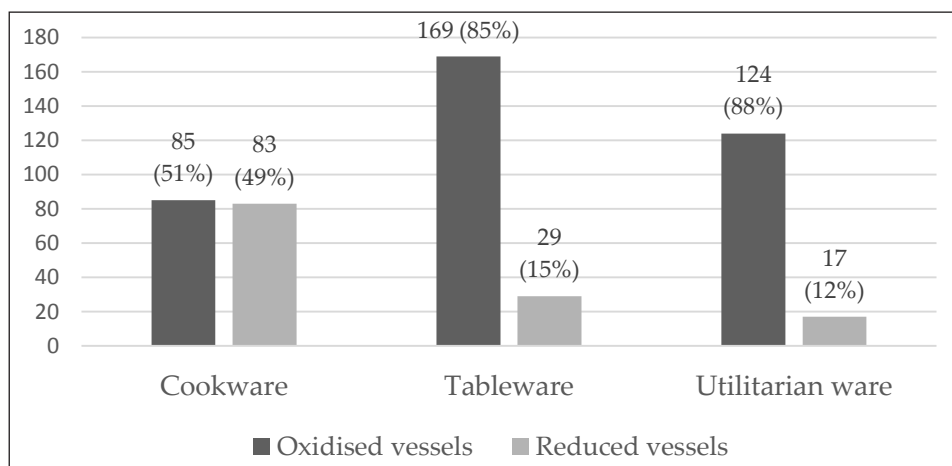

Figure 8. The proportion of oxidized/reduced wares according to the main functional categories.

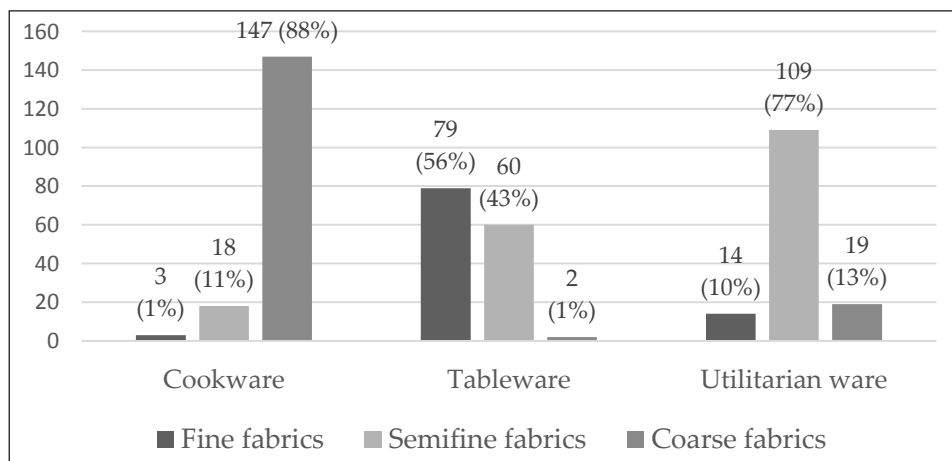

Figure 9. The distribution of the fabrics categories according to the main functional groups.

ware of semifine-, while the cookware of coarse fabrics. Moreover, the oxidized fabric types are predominant with the tableware and utilitarian ware, while the reduced fabrics can mostly be found with the cookware. The same can be said with regard to the question of colour-coating. Virtually all of the tableware vessels were colour-coated, the overwhelming majority – encompassing the pieces fired in an oxidized environment – corresponding to the category of so-called ‘red-slip ware’, covered with either brick-red, brownish red, or occasionally red-orange engobe. Not surprisingly, the incidence of colour-coating is much lower in the case of the utilitarian ware, however its quantification is hindered by the fact that flagons and jugs were often only partially colour-coated, a situation which is impossible to assess based on a fragmentary assemblage. Naturally, no instances

of colour-coating could be identified within the cooking ware, as no examples of Pompeian-red ware with the characteristic internal non-stick slip were found in the assemblage.

Concerning the chronology of the 'local production', there are extremely few relevant indications in this case given the unstratified and very fragmentary nature of the assemblage. It has been previously noted however, that the lid-seated, necked pots/jars with angular rims, quite ubiquitous in the current assemblage were not common in the local production of Apulum/Alba Iulia until the mid-late-2nd century.³³² The implications of this observation with regard to the dating of the cookware from the Buciumi barracks are however impossible to assess at this time.

4.2.1. The tableware (including the terra sigillata)

4.2.1.1. The local production

The category consists of vessels primarily used for serving foods and drinks. A clear distinction between the two is often difficult to make, especially in the case of smaller sized bowls or wider cups, one of the most common dilemmas involving the choice between drinking cup and dipping bowl (*acetabulum*). As mentioned above, these vessels are commonly made from fine fabrics and have engobe colour-coating. The vessels employed for food serving, consisting of bowls, dishes, and platters, are generally derived to varying degrees from terra sigillata shapes (Figures 12, 13).³³³ There is potentially a distinct category characterized by the higher quality of the fabrics, the engobe and the firing (fabrics: OF 1 and OF 4), and the clear intention to emulate the imported vessels, however, given that this tendency is to a certain extent generally available for the entire category of tablewares, it will not be discussed separately. The category of vessels used for serving food is clearly dominated by the various types of bowls (Figure 10) with 66% of the fragments belonging to this class. A further conspicuous fact is related to the extremely low incidence of drinking vessels which potentially indicates the preference of dining recipients made from other materials, primarily glass, indeed fragments coming from well over one hundred glass vessels were reported in the monograph, albeit, naturally, the category does not contain only drinking vessels.³³⁴ The containers from this category are mostly undecorated, the only exceptions are two instances of cut-glass decoration on a bowl (BO 1) and a beaker (BE 3), both directly linked to terra sigillata shapes.

The following section focuses on the local production, subsequently followed by the discussion related to the imported finewares.

1) Bowls (BO)

The category includes neckless hemispherical vessels without handles, usually fitted with a footring. According to Webster's definition, its height is more than one third, but less than its entire diameter.³³⁵ Bowls make up the larger part of the tableware from the barracks in Buciumi, their quantity being matched by their morphological variety. Over half of the vessels belong to type BO 2 also termed 'bowls with central cordon' derived from the type Drag. 44 (Figure 11), which was popular across the latter half of the 2nd century AD. A further characteristic of the respective type is its wide opening often in excess of 300 mm, while the other types usually have openings with a diameter of around 200 mm (see below Chapter 4.3). A further type, BO 1 is loosely based on one of the most prolific Gaulish terra sigillata types, namely Drag. 37 (Figure 12).

³³² Ciușescu 2006, 147.

³³³ Petruț 2016.

³³⁴ Chirilă et al. 1972, 109–114. There is hitherto no specialist report on the glass finds, hence the uncertainty of the quantification.

³³⁵ Webster 1976, 17.

Furthermore, it is important to underline that several types comprise only one or two vessels. In some cases the fragments apparently belonging to bowls were too small for classification, one such instance was illustrated (Pl. 6/5).

Catalogue of forms:

BO 1 (Pl. 4/1–2, 5/6, 6/1, 19/10). Slightly everted rim, thickened beaded lip, external horizontal groove below the rim. Loosely based on Drag. 37. Fabric type OF 2 predominates (seven cases), usually in conjuncture with reddish-brown colour-coating. Other fabrics: OF 1 (two cases), OF 3 (one case). Bright brick-red colour-coating emulating terra sigillata slips also present in addition to one instance of cut-glass decoration (Pl. 6/1, 19/10). In this case the simple cut-glass ornamentation was employed to substitute the more sophisticated relief ornaments of the Drag. 37 type terra sigillata bowls. Analogies for this type were reported at the military works-depot of Legio XX Valeria Victrix, at Holt in Roman Britain,³³⁶ but also in an assemblage discovered in the legionary base at Apulum/Alba Iulia.³³⁷

BO 2 (Pl. 4/3–4). ‘Bowls with central cordon’, slightly inturned rim, thickened beaded lip, external horizontal ridge below the rim. Loosely based on Drag. 44. The type comprises the largest group of vessels (forty-nine). The fabrics are quite varied, the largest group belongs to OF 1 (fifteen cases), followed by OF 3 and OS 3, both with seven cases, respectively OF 2 and OS 2 with five cases. Several instances of semifine fabrics (OS 2, OS 3, OS 4, and RS 1) and one instance of course fabric (OC 2)³³⁸ can also be reported, in addition to seven cases of reduced fabrics (RF2 and RS 1). Most vessels have brick red colour-coating, while reddish-brown and orange coating is also featured on a number of vessels. The reduced fabrics are associated with grey and black colour-coating.

BO 3 (Pl. 5/1). Short outcurved rim, rounded lip. The type comprises only two vessels, both with RF 2 fabrics and black engobe.

BO 4 (Pl. 5/2). Short everted rim, subangular lip, repeated external horizontal grooves under the rim. The type comprises only one vessel, fabric type: RF 2 with grey coating.

BO 5 (Pl. 5/3). Vertical opening, reeded flange rim, rounded lip. The type comprises only one vessel, fabric type: RS 1 without coating. The style of the rim possibly suggests a similar use to that of the *mortaria*.

BO 6 (Pl. 5/4). Inturned rim, beaded and slightly outcurved lip with external horizontal base groove. The type comprises only one vessel, fabric type: RS 1 without coating.

BO 7 (Pl. 5/5). Vertical rim, slightly everted beaded lip, repeated external horizontal grooves. The fabrics are diverse, the largest groups belonging to OF 1 and OF 2, both with four vessels, and OS 3 with three vessels. One instance of reduced ware: RS 1. The colour-coating is equally varied with no dominant type.

BO 8 (Pl. 6/2). Inturned rim, thick beaded lip. The fabrics are quite diverse, the largest was ascribed to OF 1 with five vessels. There are two instances of reduced wares (RF2 and RS 1). Most vessels have reddish-brown coating.

³³⁶ Greene 1977, 120, Fig. 8.3/1; Swan 2004, 264 Fig. 1/7.

³³⁷ Ciaușescu 2006, Pl. 3/76–78.

³³⁸ It is debatable whether in this case we are dealing with a container used for serving food or a heating/cultic implement similar to the *turibula*-class vessels.

BO 9 (Pl. 6/3). Inturned rim, beaded lip with horizontal external base groove and internal cannelure. A similar shape was published in the monograph.³³⁹ The fabrics are quite varied, the largest group belonging to OS 3 with three vessels. The colour-coating is equally varied with no dominant type. The type is featured in the monograph.³⁴⁰

BO 10 (Pl. 6/4). Inturned rim, beaded lip with lid-seating. The type comprises only one vessel, fabric type: OF 1 with brick red colour coating.

2) Dishes (DI)

Dishes are defined here as the vessels with the lowest height, which usually does not exceed one seventh of its diameter. Three types have been identified, all connected to a certain degree to terra sigillata shapes: 1) Drag. 36 style dishes with long outcurved rims, 2) Curle 15/23 style carinated dishes, and 3) hemispherical dishes probably linked to type Drag. 32 (Figure 13). The overall diameters of the dishes is lower than that of the bowls. Very few such vessels are illustrated in the 1972 monograph, indeed the authors of the report underlined the fact that a number of fragments ascribed to this form, termed as 'shallow bowls with footring base' is very low.³⁴¹ The published drawings in fact illustrate only two shapes,³⁴² given their sketchy style however, they do not allow analogies with the current assemblage.

Catalogue of forms:

DI 1 (Pl. 7/1–2). Slightly outcurved horizontal rim with a horizontal groove, sub rectangular lip, and carinated body. Loosely based on Curle 15. The fabrics are varied, with no predominant type: OF 1, OF 2, and OS 3. The colour-coating is usually brick red. One instance displaying an ownership mark graffito (see below) (Pl. 7/1).³⁴³

DI 2 (Pl. 7/3–4). Long outcurved rim, rounded lip sometimes with a groove at its base, and an internal ridge at the base of the rim. Loosely based on Drag. 36, although the body is slightly carinated. The fabrics are varied with no predominant type: OF 1, OF 2, OF 3, and OS 3. The colour-coating is usually brick red.

DI 3 (Pl. 7/5). Flanged rim with an internal groove at its base, rectangular lip and carinated body. Loosely based on Curle 23 (notwithstanding the angular flanged rim). The type comprises only one vessel, fabric type: OF 1 with brick red coating.

DI 4 (Pl. 8/1). Everted rim with rounded lip. Slightly carinated body and internal horizontal groove above the base. The type comprises two vessels, fabrics: OF 4 and OS 1, both with brick red coating.

DI 5 (Pl. 8/2). Horizontal rim, rounded lip with external horizontal groove at its base, and hemispherical body. Loosely based on Drag. 32. The type comprises only one vessel with OF 4 fabrics and brick red coating.

3) Platters (PL)

The containers belonging to this category are characterised by a reduced height, comparable

³³⁹ Chirilă et al. 1972, Pl. XV/2, XVI/4.

³⁴⁰ Chirilă et al. 1972, Pl. XVI/4.

³⁴¹ Chirilă et al. 1972, 49 (my translation).

³⁴² Chirilă et al. 1972, Pl. XVIII/3, 5.

³⁴³ Dana/Petruț 2015.

to that of the dishes, tronconical body, a mouth opening only slightly larger than the diameter of the base, inturned rim with a rounded lip and flat base. All examples are made from fine or semifine fabrics and are colour-coated. Variations of this form can also be found among the cookware, featured here as 'pans' (PA). A feature of this class is the wide mouth opening, all registered instances having diameters in excess of 300 mm. Due to their morphological characteristics this class comprises the highest number of fragments displaying full sections of the vessels, thus enabling the complete or almost complete reconstruction of their original form. Interestingly enough, the incidence of complete sections is considerably higher than that of their counterparts among the cookware, however their overall numbers are lower. Based on their dimensions it is fair to say that this class comprises large capacity containers similar to the BO 2 type bowls with central cordon. From a morphological standpoint this category is quite unitary consisting of a single type:

PL 1 (Pl. 8/3). Tronconical body, a mouth opening only slightly larger than the diameter of the base, inturned rim with a rounded lip and flat base. The range of fabrics is extremely wide, the largest groups belonging to: OS 3, OS 1, OF 1, and OS 2. The overwhelming majority are made from oxidized fabrics with brick red colour-coating.

4) Beakers (BE)

This elusive category comprises small-sized vessels with thin walls (up to 3 mm) and relatively narrow mouth openings made from semifine fabrics and presumably were used for drinking. They include containers with ovoid or globular bodies. The 1972 monograph features quite a few instances of globular and ovoid beakers,³⁴⁴ however the present assemblage provides only one such case:

BE 1 (Pl. 8/4, 19/9). Globular or ovoid body, thin walls (2 mm), cut-glass decoration consisting of horizontal rows of oval patterns. The overall shape is loosely based on type Drag. 54 or Déch. 72. The fabric is OF 3 covered in brick red colour coating. The rim is not preserved.

5) Cups (CU)

This class comprises a series of small-sized bowls with very low height, and thin walls (up to 3–4 mm) which were either used as drinking vessels or dipping-bowls (*acetabula*). The source of inspiration is difficult to assess, although it seems that some elements potentially linked to terra sigillata types Ritterling 8 and Conspectus 34 can be identified. The case of the latter is especially interesting, since the prototype – if indeed there is a connection – is a 1st century AD Italian type.³⁴⁵ The orifice of these containers usually varies between 120 and 160 mm. One fragment of type CU 1 has preserved an entire profile, based on which the original shape of the vessel was reconstructed. The affinity for this type of small bowls or cups was noted repeatedly throughout the military bases of the European frontier provinces.³⁴⁶

Catalogue of forms:

CU 1 (Pl. 8/5–6). Hemispherical body, small horizontal ridge at the middle of the vessel, slightly inturned rim, rounded lip separated from the rim by an external groove (or occasionally beaded lip), and footring at the base. The fabrics belong to types: OF 1, OF 3, and OS 3, usually in conjuncture

³⁴⁴ Chirilă et al. 1972, 43, nos. 1–15, Pl. V, VII–VIII.

³⁴⁵ Conspectus 34.1.1., 34.2.2.

³⁴⁶ Grünewald 1986, Taf. 4; Meyer-Freuler 2005, 381, Abb. 4.

with brick red or brown colour-coating. Although some variants appear to be taller (Pl. 8/6), while others less so (Pl. 8/5), these fragments were assigned to the same type.

CU 2 (Pl. 8/7). Hemispherical body, everted rim, rounded lip with external groove separating it from the rim. Fabrics: RF 2 and OF 1 in conjuncture with black and brick red colour-coating.

CU 3 (Pl. 8/8). Tronconical body, vertical thickened rim ending in a thinned rounded lip with and external groove at its base. The only fragment belonging to this type was made of RF 2 type fabric without colour coating.

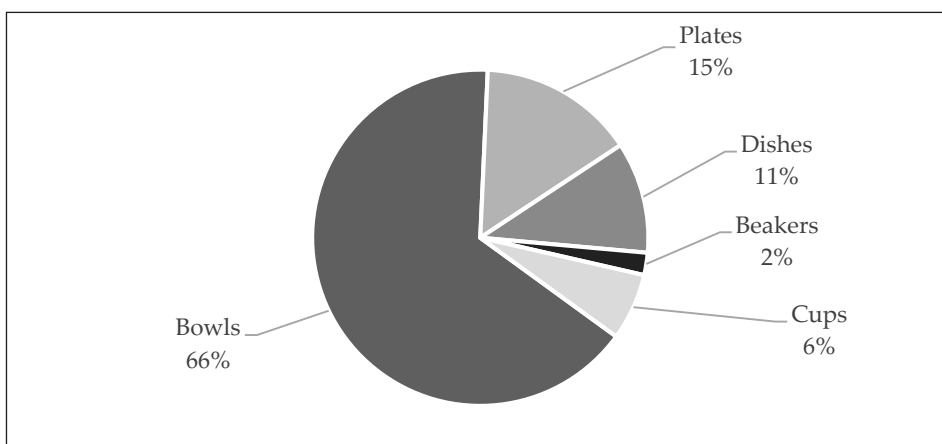

Figure 10. The distribution of the main vessel classes within the category of tableware.

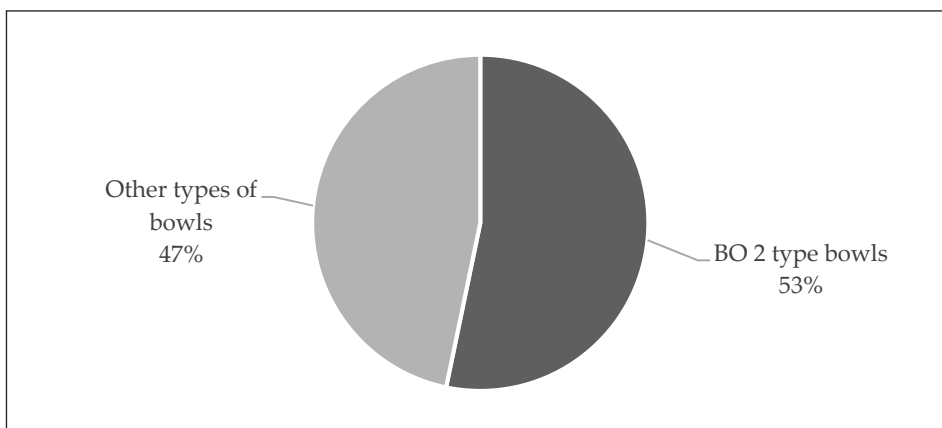

Figure 11. The distribution of BO 2 type 'bowls with central cordon', based on terra sigillata form Drag. 44.

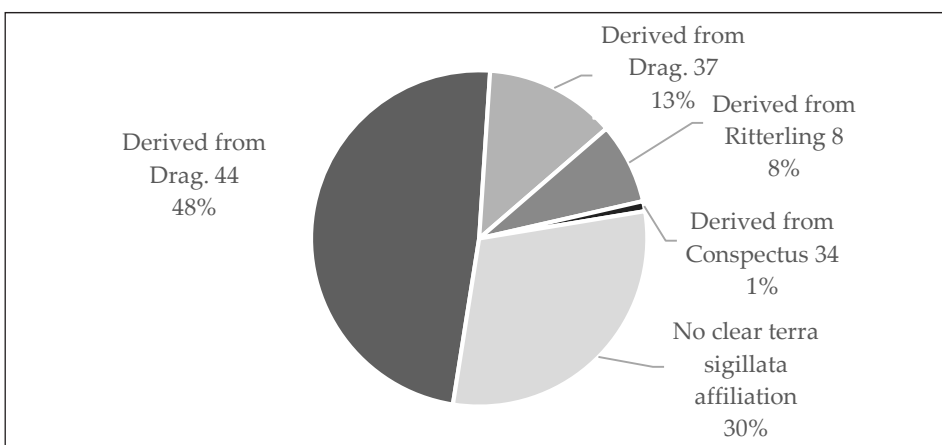

Figure 12. The distribution and proportion of bowls derived from terra sigillata forms.

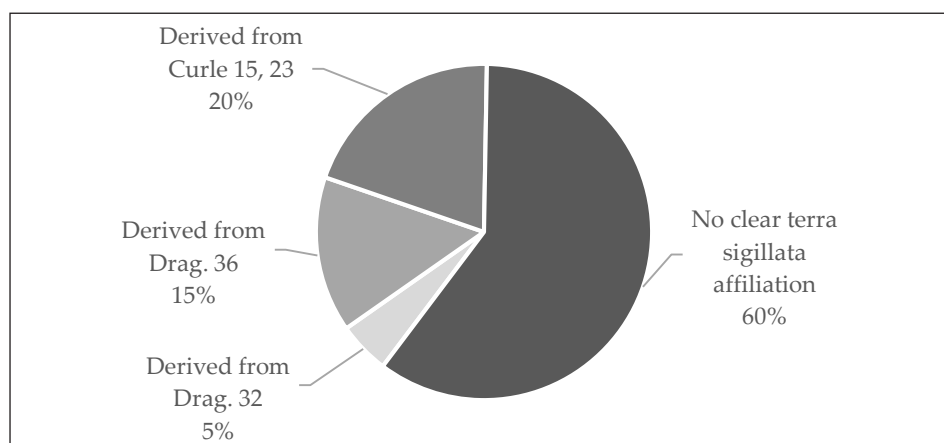

Figure 13. The distribution and proportion of dishes derived from terra sigillata forms.

4.2.1.2. *The terra sigillata*

The present report begins by attempting to disentangle the research history of the terra sigillata assemblage from Buciumi. The discussion will centre around the following aspects: 1) the classification of the vessels based on their shapes (types), 2) the classification of the vessels based on their place of production and their chronology, and 3) the spatial distribution of the material within the barracks. A catalogue of the fragments (both published and unpublished) will be given at the end.

A catalogue of the terra sigillata discovered during the excavations of 1963–70 was originally published in the 1972 monograph,³⁴⁷ however a comprehensive specialist report was only put forward later, in 1977 by Dan Isac.³⁴⁸ The maximum number of vessels present in the assemblage was placed at twenty-two, with twenty coming from the barracks.³⁴⁹ Based on the acknowledgement of the author, only the mould-decorated and stamped fragments (in addition to a roulette-decorated fragment and a complete jar) were taken into account, while a further fifteen to twenty plainware fragments were discarded. The second period of investigations produced further forty fragments, raising the overall maximum number of vessels to sixty-two, although two fragments from the second batch might indeed come from vessels published before (see below). It is important to underline that these figures are understood as ‘maximum numbers’, due to the presence of wall- and base fragments in the assemblage, some of which might come from the same vessels as the rim fragments. A precise quantification is therefore unachievable. Relatively recently, in 2014 an almost complete Drag. 37 bowl – pieced together from over twelve fragments – produced by the Central Gaulish potter known as Cettus from Les Martres-de-Veyre was published.³⁵⁰ Shortly after, chemical composition analysis (wavelength-dispersive X-ray fluorescence analysis or ‘WD-XRF’ and portable energy-dispersive X-ray fluorescence or ‘pXRF’) was carried out on the material by a team from the Excellence Cluster 264 TOPOI within the Freie Universität, Berlin. Although the immediate goal was to detect potential imports from Lower Moesia (i.e. Butovo and Pavlikeni), the analysis provided valuable information with regard to various pieces of Gaulish origin from the assemblage (see below).³⁵¹ A second set of results were since then presented at the 30th *Rei Cretariae Romanae Fautores* Congress held in Lisbon in 2016 and published quite recently, which excluded the presence of Moesian material (i.e. from the abovementioned two sites) in the analysed

³⁴⁷ Chirilă et al. 1972, 38–40.

³⁴⁸ Isac 1977.

³⁴⁹ Isac 1977, 165–170.

³⁵⁰ Petruț 2014.

³⁵¹ Baranowski et al. 2015.

group of samples, but confirmed the existence of vessels manufacture in Lezoux, Les Martres-de-Veyre and La Graufesenque.³⁵² The two parts of the assemblage, i.e. the batch published in 1972 and 1977, as well as the lot discovered after 1970 and thus mostly unpublished, will be discussed together below. Unfortunately, the lot previously published by Isac could not be re-examined, therefore most information is taken from the aforementioned specialist report, with some amendments in the interpretations. The discrepancies in the illustration of the material are also a result of this situation.

1) With regard to the distribution of forms, four clusters can be identified: 1) the group of Drag. 37 bowls comprising twenty-seven vessels, making it by far the most well represented type, 2) the Drag. 33 cups, the second largest group with eleven vessels, 3) a miscellaneous group comprising mainly dishes of various types as well as occasional drinking vessels (fourteen vessels in total), and lastly 4) the group of indeterminable fragments consisting of eleven pieces (Figure 14). The situation seems to fit the wider trend in terms of the tableware composition, as indicated by the predominance of the bowls.

2) Determining the distribution of the fragments based on their production place and implicitly their chronology is far more problematic given the high proportion of fragments without potters' stamps or sufficient mould-decoration. It is indicative of the fragmentary state of the assemblage that only one vessel can be reconstructed entirely in terms of its form and relief composition (no. **26**). Indeed, just over half of the fragments can be attributed with varying degrees of precision to a production centre (Figure 15). The determination is based on multiple methods according to the nature and quality of the information displayed by each fragment. The most straightforward category is probably that of the fragments with potter's stamps. A total of nine such cases were recorded, with seven plainware base stamps, and two mould-decorated fragments with intra-decorative as well as an infra-decorative stamps (see the catalogue below). Among the stamps of the seven plainware fragments, five were previously interpreted in the specialist report from 1977,³⁵³ while further two are unintelligible: no. **35** is a fragmentary stamp and no. **36** belongs to the category of so-called 'illiterate stamps'. The hitherto unpublished material contains only two potter's marks, a fragmentary stamp (no. **8**) and an incomprehensible tab-stamp (no. **29**), both determined on account of the preserved elements of the mould decoration. Furthermore, some eighteen fragments of decorated ware could be determined based on the combination of figure types and decorative elements employed in their ornamental compositions (see catalogue below). The original determinations were usually maintained with the exception of nos. **16**, **21**, and **22**. Finally, a number of ten fragments subjected to WD-XRF analysis revealed the production centres from which they originated, without however offering further details regarding the manufacturer and the period of its activity. A total number of twenty-eight fragments could not be determined precisely (Figure 15).

The fragments attributed to established Gaulish, Germanic and Raetian production centres can be linked to the output of workshops based in: La Graufesenque, Lezoux, Les Martres-de-Veyre, Rheinzabern and Westerndorf. These will be discussed separately below. According to the chronological features of the assemblage, the material was arranged into four groups (Figure 16): I) Trajanic-early-Hadrianic period (c. AD 106-125), II) mid-2nd century (c. AD 130-160), III) latter half of the 2nd century (c. AD 165-195), and IV) 3rd century (c. AD 200-240).

The three fragments (nos. **1-3**) attributed to the prolific South Gaulish production centre at

³⁵² Daszkiewicz et al. 2018, 548.

³⁵³ Isac 1977, 162-163.

La Graufesenque were determined through XRF analysis. All three fragments belong to dish forms (Curle 15 and Drag. 18/31). As expected, the products of this production centre are ascribed to period I. Based on the chronology of the production and export of the respective centre, the material present in Dacia can roughly be dated between the foundation of the province and c. 120 AD.³⁵⁴

By far the most numerous group is represented by products of the Central Gaulish centre at Lezoux. The workshops based at Lezoux basically cover the entire 2nd century AD terra sigillata market of Roman Dacia,³⁵⁵ with production and exports declining in the late 2nd and early 3rd century AD, during which the Danubian market was gradually taken over by the workshops based in Rheinzabern.³⁵⁶ The starting point of large-scale production and distribution of Lezoux sigillata throughout the European provinces is usually set in the late-Trajanic period.³⁵⁷ One might argue that this situation is partly reflected in the composition of the small assemblage under scrutiny here. Not surprisingly, only two fragments, both attributed to the early-2nd century potter Libertus ii (nos. **10** and **11**), can be ascribed to period I. The second period, roughly covering the mid-2nd century, comprises three fragments attributed to: Butrio (no. **12**), who was probably trained in the Libertus ii tradition, Catull- (no. **13**) standing for Catullus, Catullinus or the like, and the Ianuaris i – Quintilianus group (no. **14**). Period III, comprising the latter part of the 2nd century AD, is by far the most well-represented in terms of vessel numbers. A total of fourteen fragments, both stamped and relief-decorated can be ascribed to vessels produced by potters from Lezoux active in this period: Pateratus (no. **4**), Burdo (no. **5**), Cintusmus i (no. **6**), Sennius (no. **7**), Censorinus ii (nos. **8** and **20**), Aduocisus (no. **9**), Paternus ii (no. **15**), Albucius ii (no. **16**), Iullinus ii (no. **17**), Casurius ii (no. **18**), Mercator ii (no. **19**), Albucius ii (no. **21**), and Anunus (no. **22**).

The potteries at Les Martres-de-Veyre made their mark on the Danubian market roughly at the same time (or slightly earlier) as the manufacturers at Lezoux,³⁵⁸ although their production and export decreased considerably and eventually ceased in the latter half of the 2nd century.³⁵⁹ A total of three fragments can be attributed to the aforementioned centre, two of which are products ascribed to Cettus (nos. **29** and **30**), admittedly the only manufacturer who produced considerable exports beyond the mid-2nd century AD.³⁶⁰ The numerous conspicuous production flaws displayed by one of the Drag. 37 bowls attributed to the said potter (no. **29**) raise questions with regard to the distribution mechanisms and the quality standards of both the producer and the market.³⁶¹ The third fragment (no. **31**) was determined through XRF.

The production centre from Rheinzabern in Upper Germany took over the position hitherto filled in by the Central Gaulish producers in the Danubian market starting with the late-2nd century AD.³⁶² Although the share of Rheinzabern imports in Dacia does not rival the massive presence recorded in Pannonia, still large quantities of the respective centre's products have reached the province situated north of the Danube.³⁶³ None of the fragments displaying potter's stamp or mould-decoration could be linked to any of the Rheinzabern producers, nor did the XRF analysis indicate such an affiliation. Based on analogies, two possible Rheinzabern vessels can be identified:

³⁵⁴ Rusu-Bolindeț 2007, 152.

³⁵⁵ Rusu-Bolindeț 2007, 147, 152–155.

³⁵⁶ Gabler 2006, 72.

³⁵⁷ Bémont/Jacob 1986, 139.

³⁵⁸ Gabler 2006, 69–70.

³⁵⁹ Bémont/Jacob 1986, 146.

³⁶⁰ Tyers 1996, 113.

³⁶¹ Petruț 2014, 18.

³⁶² Gabler 2006, 76–77.

³⁶³ Rusu-Bolindeț 2007, 147.

a Déch. 72 jar (*olla*; no. 33) and a Drag. 35 dipping bowl (*acetabulum*) with barbotine decoration (no. 34). Given the output of the centre and its considerable export shares in the region, it is highly likely that a substantial share of the fragments with uncertain origin is indeed linked with Rheinzabern.

Westerndorf, the earlier of the two Raetian production centres was established during the AD 170s in order to fulfil the increasing demand of the Danubian market, a task with which the Rheinzabern potteries could no longer cope.³⁶⁴ The assemblage contains only one fragment attributed to the Comitalis group (no. 32), affiliated with the said production centre.

With regard to the chronological distribution of the assemblage, it is evident that period III, covering the latter half of the 2nd century AD is by far the most well-represented (Figure 16), probably accounting for a peak in the supply of terra sigillata to the fort. Later attempts to correlate the finds with the construction phases (dated through the reassessment of the coin finds) based on the recorded depth of each fragment, unfortunately produced contradictory results, due to the inaccurate finds recording.³⁶⁵ Based on the attribution of finds to the revised occupation phases of the fort, more than half of the sigillata material would have to be ascribed to the Trajanic–early-Hadrianic phase (1a), a clearly improbable scenario.

3) With regard to the question of spatial distribution, it is important to point out the fact that virtually the entire assemblage comes from the barracks of the fort. A further important aspect once again concerns the question of finds recording, as more or less clear spatial information regarding the findspots within the barracks are restricted to the material discovered after 1971. Unfortunately, the low resolution of the data does not allow the attribution of finds to individual *contubernia*, however in some cases a differentiation between the centurion's quarter placed in the vicinity of the *via sagularis* and the men's chambers in general can be asserted. The contrast is most evident in the case of barracks no. 2, with a total of eighteen fragments coming from the centurion's quarter, and only six from the *contubernia* (Figure 17). The situation is somewhat less telling in the case of barracks no. 1, where only four fragments can be linked with the centurion's quarter as opposed to five from the *contubernia* (Figure 18). Although less spectacular than the previous case, considering the small area of the centurion's quarter relative to the entire surface of the barracks, it still indicates a predominance of the material in the area of the commander's chambers. Similar cases have been reported in the past. In the fort at Bearsden along the Antonine Wall, David J. Breeze noticed that twenty-three out of a total twenty-seven sigillata fragments coming from one barracks block were discovered in the centurion's quarter.³⁶⁶ The situation was similar in the case of other two barracks researched in the respective fort. Further analogous cases come from the Flavian fort at Elginhaugh in Scotland,³⁶⁷ and the legionary base at Haltern in Germany, where the terra sigillata was concentrated in the tribune's residence and the centurion's quarters.³⁶⁸ In the case of Elginhaugh it was also noted that both ends of the barracks blocks displayed high concentrations of sigillata, indicating that the opposing ends relative to the centurion's quarters were also (perhaps temporarily) occupied by officers.³⁶⁹ The analogies from the three aforementioned military bases are highly relevant given their relatively short occupation, which means that the spatial distribution of the finds was most likely not affected by the changes in the position and orientation of the internal buildings.

³⁶⁴ Gabler 2006, 81–85.

³⁶⁵ Găzdac/Pripon 2012, 19, 26–27.

³⁶⁶ Breeze 1977, 135–136.

³⁶⁷ Hartley 2007, 396.

³⁶⁸ Davison 1989, 243.

³⁶⁹ Hartley 2007, 396.

La Graufesenque

Plainware determined through XRF analysis

1. Curle 15 dish; rim fragment. Pl. 14/3, 18/4.

Unknown potter and dating.

Provenance analysis: Baranowski et al. 2015, no. BM 370; Daszkiewicz et al. 2018, no. BM 370 (F 4).

Barracks no. 2; X. 40 m, d. 1.4 m.

Unpublished. Dm. 190 mm, H. 23 mm, Th. 5 mm. Traces of secondary burning.

Inv. no. 606/1973.

2. Curle 15 dish; rim fragment. Pl. 14/7, 18/7.

Unknown potter and dating.

Provenance analysis: Baranowski et al. 2015, no. BM 373; Daszkiewicz et al. 2018, no. BM 373 (F 7).

Barracks no. 1; X. 16–31 m, Y. 4–8 m, d. 0.6–0.8 m.

Unpublished. Dm. 400 mm, H. 34 mm, Th. 6 mm.

Inv. no. 386/1973.

3. Drag. 18/31 dish; rim fragment. Pl. 14/2, 18/3.

Unknown potter and dating. Dull slip.

Provenance analysis: Baranowski et al. 2015, no. BM 384; Daszkiewicz et al. 2018, no. BM 384 (F 18).

Barracks no. 1; X. 43–46 m, Y. 0–4 m, d. 1 m.

Unpublished. Dm. 200 mm, H. 30 mm, Th. 5 mm.

Inv. no. 647/1973.

Lezoux

a. Potter's stamps (fragments of plainware and decorated ware with potter's stamps)

4. Drag. 31 dish with potter's stamp; base fragment. Pl. 10/6.

Pateratus: c. AD 135–170 (cf. SR, Pateratus).

Stamp: PATERATIOF, die: 1a; base stamp.

Barracks no. 5.

³⁷⁰ For the sake of intelligibility the catalogue entries are ordered according to the vessels' place of production and their chronology. The subsets of these groups, depending on the means of origin determination are: a. the fragments with potter's stamps, b. decorated ware fragments (without stamps), and c. the fragments determined through WD-XRF (wavelength dispersive X-ray fluorescence) analysis. All vessels have oxidized fabrics and are covered by glossy brick red colour-coating (slip) unless specified otherwise (e.g. 'terra nigra'). Moreover, all entries refer to one fragment unless specified otherwise. The description of the contexts in quotation marks (") represent translations of the original entries in the museum's finds register. For his invaluable help in determining the provenance of certain fragments I wish to express my gratitude to Professor Dénes Gabler from Budapest.

The artefacts included in the finds catalogue have a continuous numbering throughout the book. The explanation of technical abbreviations used in the catalogue can be found at the end of the book at the section 'Abbreviations used in the catalogues.'

Chirilă et al. 1972, 39, no. 31, Pl. III/8; Isac 1977, 169, no. 17, Pl. IV/ 17; SR 105787.
Inv. no. 276/1969, Mus. Zalău.

5. Drag. 33 (?) cup with potter's stamp; base fragment. Pl. 10/2.

Burdo (Burdus): c. AD 140–170 (cf. SR, Burdo).

Stamp: BVRDOF, die: 6b; base stamp.

Barracks no. 2; Section XIII/m. 132, i.e. the centurion's quarter; d. 0.83 m.

Chirilă et al. 1972, 39, no. 33, Pl. III/11; Isac 1977, 169, no. 15, Pl. III/15; SR 36078.

Unknown Inv. no., Mus. Zalău.

6. Drag. 18/31 dish with potter's stamp; base fragment. Pl. 10/5.

Cintusmus i: c. AD 140–180 (cf. SR, Cintusmus i).

Stamp: CIN[tusmi], die: 3g; base stamp.

Barracks no. 4.

Chirilă et al. 1972, 39, no. 34, Pl. III/10; Isac 1977, 169, no. 16, Pl. III/16; SR 47510.

Inv. no. 117/1970, Mus. Zalău.

7. Drag. 33 dish with potter's stamp; base fragment. Pl. 10/3.

Sennius: c. AD 145–165 (cf. SR, Sennius).

Stamp: SENNIVSE, die: 2a; base stamp.

Barracks no. 5; d. 1 m.

Chirilă et al. 1972, 39, no. 29, Pl. III/6; Isac 1977, 169–170, no. 18, Pl. IV/18, V/18; SR 133329.

Inv. no. 268/1969, Mus. Zalău.

8. Drag. 37 bowl. Mould-decorated vessel; wall fragment. Pl. 12/1, 17/2.

Censorinus ii: c. AD 160–190 (cf. SR, Censorinus ii).

Stamp: CEN[sorini], die 1a, intra-decorative.

Barracks 1; X. 45 m, Y. 6–11 m, d. 0.5 m.

Unpublished (featured in SR 202437). H. 64 mm, Th. 7 mm, W. 48 mm.

Ovolo bordered beneath by an astragalus; flying pigeon (Déch. 1010 = Osw. 2317).

Inv. no. 720/1973, Mus. Zalău.

9. Drag. 33 cup with potter's stamp; base fragment. Pl. 10/1.

Aduocisus: c. AD 160–200 (cf. SR, Advocisus).

Stamp: ADVOCISIO, die: 2a; base stamp.

Barracks no. 5; d. 0.4 m

Chirilă et. al 1972, 39, no. 30, Pl. III/7; Isac 1977, 169, no. 14, Pl. III/14, V/14; SR 15527.

Inv. no. 175/1969, Mus. Zalău.

b. Decorated ware

10. Drag. 37 bowl. Mould-decorated; wall fragment. Pl. 9/1.

Libertus ii: c. AD 100–120 (cf. Isac 1977); c. AD 105–130 (cf. SR, Libertus ii).

Barracks no. 2.

Chirilă et al. 1972, 39, no. 22, Pl. II/18; Isac 1977, 165, no. 1, Pl. I/1.

Seated male figure with a scroll in his hands (Déch. 528 = Osw. 138); a kneeling female figure being restrained from the back by another human figure (Déch 578 = Osw. 985); rectangular panels composed by garlands with rosettes in the corners; laurel wreath medallions.

Inv. no. 24/1965, Mus. Zalău.

- 11.** Drag. 37 bowl. Mould-decorated; wall fragment. Pl. 12/2, 17/7.
 Libertus ii: c. AD 100–120 (cf. Isac 1977); c. AD 105–130 (cf. SR, Libertus ii).
 Barracks no. 2.
 Unpublished. H. 52 mm, Th. 11 mm, Lg. 66 mm.
 Same seated figure as in the precedent case (Déch. 528 = Osw. 138); bird in the laurel wreath medal-
 lion above.
 Inv. no. 391/1972, Mus. Zalău.
 The possibility that the fragment belonged to the same vessel as no. **10** cannot be ruled out entirely,
 however, the long period between the discoveries of the two fragments would speak against this.
- 12.** Drag. 37 bowl. Mould-decorated; wall fragment. Pl. 12/4, 17/8.
 Butrio: c. AD 115–145 (cf. SR, Butrio).
 Barracks no. 2. D. 0.8 m ('in the central part of the barracks').
 Unpublished. H. 53 mm, Th. 7 mm, Lg. 45 mm.
 Ovolò bordered beneath by a wavy line; peacock or seagull (Osw. 2254/2255); bead flanked by two
 reels (Déch. 1111 = Osw. 865)
 Inv. no. 334/1973, Mus. Zalău.
- 13.** Drag. 37 bowl. Mould-decorated; wall fragment. Pl. 9/2.
 Catull- (Potter X 6):³⁷¹ c. AD 125–150 (cf. Isac 1977); c. AD 125–145 (cf. SR, Catull-).
 Barracks no. 5.
 Chirilă et al. 1972, 38, no. 3, Pl. I/3; Isac 1977, 165, no. 2, Pl. 1.
 Ovolò (darts with star endings) bordered below by a wavy line; bear (similar to Déch. 809 and Osw.
 1597) and lion (similar to Déch. 755) fighting.
 Inv. no. 77/1966, Mus. Zalău.
- 14.** Drag. 37 bowl. Mould-decorated; wall fragment. Pl. 9/3.
 Ianuaris i – Quintilianus: c. AD 125–150 (cf. Isac 1977).
 Barracks no. 4; d. 1 m.
 Chirilă et al. 1972, 38, no. 1, Pl. I/1; Isac 1977, 166, no. 3, Pl. I/3.
 Ovolò bordered below by a wavy line; row of dotted medallions; vine leaf (Déch. 1148).
 Inv. no. 202/1970, Mus. Zalău.
- 15.** Drag. 37 bowl. Mould-decorated; seven wall fragments. Pl. 9/4.
 Paternus ii: c. AD 145–190 (cf. Isac 1977), or c. AD 160–180/190.
 Barracks no. 4; d. 0.8 m.
 Chirilă et al. 1972, 38–39, nos. 7, 10, 11, 20, Pl. II/3, 6, 7, 16; Isac 1977, 166, no. 4, Pl. 1.
 Ovolò bordered below by a wavy line; freestyle hunting scene: gazelle (Osw. 1849); large and small
 dogs; filling elements (Déch. 1109 = Osw. 1696).
 Inv. no. 224/1970, Mus. Zalău.
- 16.** Drag. 37 bowl. Mould-decorated; two wall fragments. Pl. 9/5.
 Albucius ii (?): c. AD 140/145–180 (cf. SR, Albucius ii); Cinnamus, cf. Isac 1977.
 Barracks no. 5; d. 0.4 m.
 Chirilă et al. 1972, 38–39, nos. 17, 18, Pl. II, 14, 15; Isac 1977, 166, no. 5, Pl. 1.
 Minerva with a shield (Déch. 77 = Osw. 126); cupid (Osw. 419); Apollo with a laurel leaf (Déch. 56
 = Osw. 93).

³⁷¹ Stanfield/Simpson 1958, 152, pl. 74–76.

Inv. nos. 166/1969, 198/1969, Mus. Zalău.

17. Drag. 37 bowl. Mould-decorated; two wall fragments. Pl. 9/6.

Iullinus ii (?): c. AD 160–200 (cf. Isac 1977; for the chronology cf. SR, Iullinus ii); c. AD 160–180 in the case of the Danubian provinces.

Barracks no. 5.

Chirilă et al. 1972, 38–39, nos. 6, 23, Pl. II/2, 19; Isac 1977, 167, no. 6, Pl. 2.

Triton (Déch. 16 = Osw. 19); cupid (Déch. 264 = Osw. 440); possible large double medallion.

Inv. no. 216/1968, Mus. Zalău.

18. Drag. 37 bowl. Mould-decorated, black slip, 'terra nigra' ('black samian'); wall fragment. Pl. 9/8.

Casurius ii: c. AD 155–190 (cf. Isac 1977; for the chronology cf. SR, Casurius ii).

Barracks no. 5; d. 0.45 m.

Grey fabrics.

Chirilă et al. 1972, 39, no. 21; Isac 1977, 167, no. 8, Pl. 2.

Ovolo bordered beneath by beaded row; Apollo with the laurel leaf (Déch. 56 = Osw. 93).

Inv. no. 157/1969, Mus. Zalău.

19. Drag. 37 bowl. Mould-decorated; wall fragment. Pl. 9/9.

Mercator ii (?): c. AD 170–190.

Barracks no. 2.

Chirilă et al. 1972, 38, no. 15, Pl. II, 11; Isac 1977, 167–168, no. 9, Pl. 2.

Amphora; astragalus; large double medallion.

Inv. no. 109/1966, Mus. Zalău.

20. Drag. 37 bowl. Mould-decorated; wall fragment. Pl. 12/5, 17/9.

Uncertain: Censorinus ii (?): c. AD 160–190.

Barracks no. 2; 'south-western end of the barracks', i.e. the centurion's quarter; d. 0.3 m.

Unpublished. H. 39 mm, Th. 7 mm, Lg. 38 mm. The fragment displays signs of strong secondary burning, in addition to sooting on the surface, its fabric has turned grey.

Ovolo bordered beneath by a beaded row.

Inv. no. 273/1973, Mus. Zalău.

21. Drag. 37 bowl. Mould-decorated; seven wall fragments. Pl. 9/10.

Albucius ii (?): c. AD 160–195; c. AD 145–175 (cf. SR, Albucius ii).

Barracks no. 4.

Chirilă et al. 1972, 38–39, nos. 5, 12, 13, 14, 19, 24, 25, Pl. II/1, 8, 9, 10, 1, Pl. III/1, 2; Isac 1977, 168, no. 10, Pl. 2.

Ovolo bordered beneath by a beaded row; Apollo with the laurel leaf (Déch. 56 = Osw. 93); nude male figure sitting; lion (Déch. 759); small medallions; astragalus.

Inv. no. 210/1970, Mus. Zalău.

22. Drag. 37 (?). Mould-decorated; wall fragment. Pl. 9/11.

Anunus: c. AD 140/150–180 (cf. SR, Anunus).

Barracks no. 2.

Chirilă et al. 1972, 38, no. 8, Pl. II/4; Isac 1977, 168, no. 11, Pl. 2.

Standing figure; lion.

Inv. no. 88/1966, Mus. Zalău.

23. Drag. 37 bowl. Mould-decorated, black slip, 'terra nigra' (black samian) wall fragment. Pl. 9/12.

Uncertain, 2nd century AD (?).
Barracks 4; d. 0.4 m.
Yellowish fabric.
Chirilă et al. 1972, 39, no. 27, Pl. III/4; Isac 1977, 168, no. 12, Pl. 3.
Inv. no. 166/1969, Mus. Zalău.

c. Plainware and decorated ware determined through XRF analysis

24. Drag. 37 bowl. Mould-decorated; rim fragment. Pl. 12/3, 17/3.

Unknown potter and dating.

Provenance analysis: Baranowski et al. 2015, no. BM 374; Daszkiewicz et al. 2018, no. BM 374 (F 8).

Barracks 2; X. 47 m, ('close to the *via sagularis*', i.e. in the centurion's quarter), d. 1.2 m.

Unpublished. Dm. 260 mm, H. 65 mm, Th. 7 mm.

Ovolo bordered beneath by a beaded row; large double medallion.

Inv. no. 325/1973, Mus. Zalău.

25. Curle 21 *mortarium*; two rim- and wall fragments. Pl. 16/6, 19/6.

Unknown potter and dating.

Provenance analysis: Baranowski et al. 2015, no. BM 382; Daszkiewicz et al. 2018, no. BM 382 (F 16).

Barracks no. 2; 'central part of the barracks'; d. 0.8 m.

Unpublished. Dm. 220 mm, H. 32 mm, Th. 7 mm. The fragment displays signs of strong secondary burning, in addition to sooting on the surface, its fabric has turned grey.

Inv. no. 338/1973, Mus. Zalău.

26. Curle 23 dish; two base- and wall fragments. Pl. 14/1, 18/2.

Unknown potter and dating.

Provenance analysis: Baranowski et al. 2015, no. BM 368; Daszkiewicz et al. 2018, no. BM 368 (F 2).

Barracks no. 2.

Unpublished. Dm. 110 mm, H. 20 mm, Th. 9 mm.

Inv. no. 391, 392/1972.

27. Drag. 36 dish; rim fragment. Pl. 14/6, 18/9.

Unknown potter and dating.

Provenance analysis: Baranowski et al. 2015, no. BM 367; Daszkiewicz et al. 2018, no. BM 367 (F 1).

Barracks no. 2; 'near the southern wall'; d. 1 m.

Unpublished. Dm. 300 mm, H. 12 mm, Th. 4 mm.

Inv. no. 438/1973, Mus. Zalău.

28. Drag. 37 bowl; rim fragment. Pl. 13/4, 17/6.

Unknown potter and dating.

Provenance analysis: Baranowski et al. 2015, no. BM 371; Daszkiewicz et al. 2018, no. BM 371 (F 5).

Barracks no. 2; X. 43–50 m, Y. 0–5.5 m, 'next to the *via sagularis*', i.e. in the centurion's quarter; d. 1.1 m.

Unpublished. Dm. 240 mm, H. 42 mm, Th. 7 mm.

Inv. no. 392/1973, Mus. Zalău.

Les Martres-de-Veyre

29. Drag. 37 bowl; integral section consisting of twelve rim-, wall-, and base fragments. Pl. 11/1a–b, 17/1a–b.

Cettus ('the small-S potter'):³⁷² c. AD 130–160 (cf. SR, Cettus; NOTS, Cettus).

Stamp: incomprehensible tab-stamp, die: 1a (?); infra-decorative.

Provenance analysis: Baranowski et al. 2015, no. BM 383; Daszkiewicz et al. 2018, no. BM 383 (F 17).

Barracks no. 2; X. 45–50 m, Y. 0–5.5 m; 'next to the *via sagularis*', i.e. in the centurion's quarter; d. 1.1–1.2 m

Petruț 2014; SR 202440; Dm. (mouth) 220 mm, Dm. (base) 80 mm, H. 108 mm, Th. 7 mm.

The ovolo's upper half was probably removed during the finishing process ('half-ovolo'). The decorated area starting below the beaded row is divided into rectangular panels bordered by beaded lines. Each panel is sectioned by two other diagonal beaded lines. Horizontal double volute motifs are placed on the middle, as well as on the upper and the lower end of the vertical beaded lines, each being associated with two flower buds oriented toward opposite directions. Small cupids with a raised hand are placed on the basal ridge below the central axis of each panel. A tab-stamp displaying a raised rectangular label with rounded corners and sunken letters was placed just below the basal ridge. In the basal interior, a quite regular ring-shaped pattern composed of small spots on the slip can be noted, probably the imprint of a stacking ring; the maximum thickness of the circular outline is around 80 mm, while its maximum diameter is 67 mm.

Inv. nos. 392/1972 (3×), 391/1972, 379/1972, 309/1973, 340/1973, 603/1973, 597/1973, 612/1973, Mus. Zalău.

30. Drag. 37 bowl; two wall fragments. Pl. 9/7.

Cettus ('the small-S potter'): c. AD 130–160.

Barracks no. 2 or 5 (conflicting information).

Chirilă et al. 1972, 38, nos. 2, 9, Pl. I/2, Pl. II/5; Isac 1977, 167, no. 7, Pl. II/7a–b.

The fragments present the same composition as the previous entry (no. **29**).

Inv. no. 22/1965, 104/1966, Mus. Zalău.

The possibility that the fragment belonged to the same vessel as no. **29** cannot be ruled out entirely, however, the long period between the discoveries of the two fragments would speak against this.

31. Uncertain type of bowl; two rim fragments. Pl. 16/5, 19/4.

Unknown potter and dating.

Provenance analysis: Baranowski et al. 2015, no. BM 372; Daszkiewicz et al. 2018, no. BM 372 (F 6).

Barracks no. 2; 'next to the *via sagularis*', i.e. in the centurion's quarter; d. 1.5 m.

Unpublished. Dm. 200 mm, H. 15 mm, Th. 6 mm.

Inv. no. 405/1973, Mus. Zalău.

Westerndorf

32. Drag. 37 bowl; wall fragment. Pl. 9/13.

Comitalis: c. AD 170–240 (cf. Isac 1977; for the chronology cf. NOTS, Comitalis).

Barracks no. 5.

Chirilă et al. 1972, 38, no. 16, Pl. II/12; Isac 1977, 168, no. 13, Pl. III/13.

Panther, deer; pine branch.

Inv. no. 210/1970, Mus. Zalău.

³⁷² Stanfield/Simpson 1958, 247.

Rheinzabern (?)

33. Déch. 72 jar (*olla*); restored complete vessel. Pl. 10/8.
Unknown potter and dating. Possibly produced in Rheinzabern.
Barracks no. 5; d. 1 m.
Chirilă et al. 1972, 39, no. 38, Pl. V/7, VIII/3; Isac 1977, 170, no. 21, Pl. V/21.
Inv. no. 251/1969, Mus. Zalău.

34. Drag. 35 dipping bowl (*acetabulum*); rim fragment. Pl. 15/1, 18/8.
Unknown potter and dating. Possibly produced in Rheinzabern.
Barracks no. 2; X. 23–27 m, Y. 0–4 m, d. 1–1.1 m.
Unpublished. Dm. 140 mm, H. 30 mm, Th. 5 mm.
The rim is decorated with barbotine stripes.
Inv. no. 315/1973, Mus. Zalău.

Fragments with uncertain origin

35. Unidentifiable vessel type with potter's stamp. Pl. 10/4.
Stamp: [---]TI; base stamp.
Barracks no. 5.
Chirilă et al. 1972, 39, no. 32, Pl. III/9; Isac 1977, 170, no. 19, IV/19, V/19.
Inv. no. 271/1969, Mus. Zalău.

36. Unidentifiable vessel type with an 'illiterate stamp'. Pl. 10/7.
Stamp: incomprehensible; base stamp.
Chirilă et al. 1972, 39, no. 28, Pl. III/5; Isac 1977, 170, no. 20, Pl. IV/20, V/20.
Inv. no. 118/1968, Mus. Zalău.

37. Unidentifiable vessel type with roulette decoration. Pl. 10/9.
Roulette decoration.
Isac 1977, 170, no. 22, V/22.
Inv. no. 217/1970, Mus. Zalău.

38. Unidentifiable mould-decorated vessel; wall fragment. Pl. 12/6, 17/10.
Apollo holding a lyre (Déch. 52 = Osw. 83). The figure-type can be encountered in Lezoux, especially on the products of Cinnamus and Paternus.³⁷³
Barracks no. 2; 'next to the *via sagularis*', i.e. in the centurion's quarter; d. 1 m.
Unpublished. H. 27 mm, Th. 7 mm, Lg. 29 mm.
Inv. no. 204/1973, Mus. Zalău.

39. Drag. 37 bowl; rim fragment. Pl. 13/1, 17/12.
Barracks no. 1; X. 32–49 m, Y. 4–9 m; d. 0.4–0.6 m.
Unpublished. Dm. 150 mm, H. 35 mm, Th. 4 mm. The slip is quite dull, the colour is pale yellowish red. The diameter of the mouth opening is surprisingly low for this vessel type.
Inv. no. 429/1973, Mus. Zalău.

³⁷³ Oswald 1937, 21; Déchlette 1904, 14, nr. 52.

40. Drag. 37 bowl; rim fragment. Pl. 13/2, 17/11.
Barracks no. 2; X. 37–38 m, Y. 0–4 m; d. 0.95 m.
Unpublished. Dm. 210 mm, H. 34 mm, Th. 6 mm.
Inv. no. 710/1973, Mus. Zalău.
41. Drag. 37 bowl; rim fragment. Pl. 13/3, 17/4.
Barracks no. 2. X. 38 m; 'next to the southern wall'; d. 1.1 m.
Unpublished. Dm. 220 mm, H. 47 mm, Th. 8 mm.
Inv. no. 431/1973, Mus. Zalău.
42. Drag. 37 bowl; rim fragment. Pl. 13/5, 17/5.
Barracks no. 2; 'in the central part of the barracks'; d. 0.8 m.
Unpublished. Dm. 260 mm, H. 38 mm, Th. 7 mm.
Inv. no. 334/1973. Mus. Zalău.
43. Drag. 37 bowl; rim fragment. Pl. 13/6, 18/1.
Barracks no. 2; X. 50–52 m, d. 0.8 m.
Unpublished. Dm. 290 mm, H. 52 mm, Th. 8 mm.
Inv. no. 662/1973, Mus. Zalău.
44. Ludowici Tg. dish; rim fragment. Pl. 14/4, 18/5.
Barracks no. 2; X. 53 m, Y. 11 m, d. 1.7 m.
Unpublished. Dm. 200 mm, H. 24 mm, Th. 7 mm.
Inv. no. 599/1973, Mus. Zalău.
45. Ludowici Tg. dish; rim fragment. Pl. 14/5, 18/6.
Barracks no. 1; X. 45 m, Y. 6–11 m, d. 0.5 m.
Unpublished. Dm. 220 mm, H. 20 mm, Th. 5 mm.
Inv. no. 720/1973, Mus. Zalău.
46. Déch. 72 / Drag. 54 jar; rim fragment. Pl. 15/2, 18/12.
Barracks no. 1.
Unpublished. Dm. 100 mm, H. 25 mm, Th. 2 mm.
Inv. no. 500/1973, Mus. Zalău.
47. Beaker/*acetabulum* of unidentifiable type (Drag. 27?); rim fragment. Pl. 15/3, 18/10.
Barracks no. 2; X. 40 m, d. 1.4 m.
Unpublished. Dm. 100 mm, H. 22 mm, Th. 4 mm.
Inv. no. 606/1973, Mus. Zalău.
48. Drag. 33 cup; rim fragment. Pl. 15/4, 18/11.
Barracks no. 2; X. 18–22 m, Y. 0–4 m, d. 1.2–1.25 m.
Unpublished. Dm. 100 mm, H. 32 mm, Th. 3 mm.
Inv. no. 379/1973, Mus. Zalău.
49. Drag. 33 cup; rim fragment. Pl. 15/5, 18/13.
Barracks no. 2; 'next to the *via sagularis*', i.e. in the centurion's quarter; d. 1.5 m.
Unpublished. Dm. 100 mm, H. 38 mm, Th. 6 mm.
Inv. no. 405/1973, Mus. Zalău.

- 50.** Drag. 33 cup; rim fragment. Pl. 15/6, 18/50.
Barracks no. 2; X. 32–49 m, X. 4–8 m, d. 0.4–0.6 m.
Unpublished. Dm. 140 mm, H. 35 mm, Th. 5 mm.
Inv. no. 311/1973, Mus. Zalău.
- 51.** Drag. 33 cup; rim fragment. Pl. 15/7, 18/15.
Barracks no. 2; X. 40 m, d. 1.4 m.
Unpublished. Dm. 150 mm, H. 33 mm, Th. 4 mm.
Inv. no. 606/1973, Mus. Zalău.
- 52.** Unidentifiable type of dish; base fragment. Pl. 16/1, 19/2.
Barracks no. 1; X. 3–4 m, Y. 0–4 m, d. 0.5 m.
Unpublished. Dm. 80 mm, H. 18 mm, Th. 6 mm.
Inv. no. 708/1973, Mus. Zalău.
- 53.** Bowl (Drag. 37?); base fragment. Pl. 16/2, 19/1.
Barracks no. 1; X. 16–31 m, Y. 4–8 m, d. 1–1.15 m.
Unpublished. Dm. 80 mm, H. 15 mm, Th. 6 mm. Traces of wear and tear in the interior.
Inv. no. 433/1973, Mus. Zalău.
- 54.** Bowl (Drag. 37?); base fragment. Pl. 16/3, 19/3.
Barracks no. 2.
Unpublished. Dm. 70 mm, H. 18 mm, Th. 8 mm. Traces of wear and tear in the interior.
Without an inv. no., Mus. Zalău.
- 55.** Bowl (Drag. 37?); base fragment. Pl. 16/4, 19/5.
Barracks no. 1; X. 0–15 m.
Unpublished. Dm. 100 mm, H. 21 mm, Th. 10 mm. Traces of wear and tear in the interior.
Inv. no. 464/1973, Mus. Zalău.
- 56.** Unidentifiable vessel type (Drag. 33?); wall fragment.
Barracks no. 1; X. 15–16 m, Y. 3 m. ‘from the daub layer’.
Unpublished. Th. 4 mm, Lg. 37 mm.
Inv. no. 409/1973, Mus. Zalău.
- 57.** Unidentifiable vessel type; wall fragment.
Barracks no. 1; ‘the northern half of the barracks’, d. 1 m.
Unpublished. Th. 5 mm, Lg. 41 mm. Dull brick red colour-coating.
Inv. no. 436/1973, Mus. Zalău.
- 58.** Unidentifiable vessel type; wall fragment.
Barracks no. 1; X. 16–31 m.
Unpublished. Th. 5 mm, Lg. 50 mm.
Inv. no. 397/1973, Mus. Zalău.
- 59.** Drag. 33 cup; rim fragment.
Barracks no. 2; X. 40 m, d. 1.4 m.
Unpublished. Dm. 140 mm, H. 21 mm, Th. 4 mm.
Inv. no. 606/1973, Mus. Zalău.

60. Bowl (?); rim fragment. Pl. 18/16.
Barracks no. 2; X. 40 m, d. 1.4 m.
Unpublished. Dm. 230 mm, H. 9 mm.
Inv. no. 606/1973, Mus. Zalău.

61. Dish (?); wall fragment. Pl. 18/17.
Barracks no. 2.
Unpublished. H. 35 mm, Th. 5 mm, Lg. 66 mm.
Inv. no. 390/1972, Mus. Zalău.

62. Unidentified vessel type; mouldmade, colour-coated only on the exterior. Pl. 16/7, 19/7.
Barracks no. 2; X. 50–54 m, Y. 3–5.6 m, d. 0.9 m.
Unpublished. H. 30 mm, Th. 4 mm, Lg. 53 mm.
Inv. no. 719/1973, Mus. Zalău.

4.2.1.3. *Other possible imported wares (thin-walled vessels, glazed vessel)*

In addition to the terra sigillata, the existence of further imported pottery vessels can be implied, albeit in small numbers. The first case is that of the so-called thin-walled vessels. No clear indication of such finds can be found in the monograph, however a beaker base covered with glossy black slip, having conspicuously thin walls can be ascribed to the category of imported thin-walled vessels.³⁷⁴ Although there is no evidence for a local production which matches, or indeed comes close to the quality of the Italian products, the so-called ‘ceramica a pareti sottili’,³⁷⁵ a clear influence in terms of forms as well as the emulation of certain technological traits (e.g. the thinning of the walls) can be observed in the local production of Dacia.³⁷⁶ This is also illustrated by the globular and ovoid beakers from Buciumi published in the 1972 monograph.³⁷⁷ The fragment in question (**63**), based on its physical traits, might possibly be the product of a North-Italian workshop. Although the exact form is impossible to assess, the flat base indicates a beaker or a small-sized bowl, both quite common in Andrea Ricci’s classification. If indeed it is an Italian product, it would imply a quite early dating, given that the production in Italy ended at the close of the 1st century AD.³⁷⁸ If this is the case, we could further imply that the respective vessel could have been the part of the material ‘baggage’ brought along by the soldiers who established the auxiliary base in Buciumi at the beginning of the 2nd century AD.

The question of the lead-glazed vessels is even less straightforward. According to John W. Hayes, the earliest Roman lead-glazed vessel production can be traced back to the 1st century BC, although an industrial production was achieved only later in certain regions, especially in 4th century AD Pannonia and Northern Italy.³⁷⁹ For Roman Dacia there is a documented local production, with the most prolific centre in Ampelum/Zlatna in the mining district of Upper Dacia.³⁸⁰ Due to their technological features and the lack of research, it is still mostly difficult, if not impossible to distinguish the local production from the imports from Pannonia or elsewhere. Admittedly, only two lead-glazed vessel fragments from Buciumi³⁸¹ were included in the

³⁷⁴ For the general characteristics, see Hayes 1997, 67–71.

³⁷⁵ Ricci 1985.

³⁷⁶ Rusu-Bolindeț 2007, 306–311.

³⁷⁷ Chirilă et al. 1972, 43, Pl. V.

³⁷⁸ Ricci 1985, passim.

³⁷⁹ Hayes 1997, 64.

³⁸⁰ Rusu-Bolindeț 2007, 323.

³⁸¹ Chirilă et al. 1972, 40, nr. 1–2.

monograph, both with scale decoration made from the lead-glaze layer covering the vessels, a quite commonly encountered technique on the finds from Dacia.³⁸² The hitherto published group from Buciumi comprises a completely preserved biconical beaker with a raised rim and one handle, similar to finds encountered in Porolissum/Moigrad, Bologna, and Apulum/Alba Iulia.³⁸³ The second find is represented by a small wall-fragment, probably coming from a similar vessel. Further two fragments of lead-glazed ware were identified among the unpublished finds produced by the latter period of research (64, 65). In both cases we are dealing with fragments of vessels covered with green lead-glaze. The first case is a beaker base with footring, displaying a large crack in the middle, probably due to the excessive thickness of the lead-glaze.³⁸⁴ The group also includes a rim fragment of a small bowl (63). Both fragments were discovered in the centurion's quarter of barracks nos. 1 and 2.

The finds catalogue:

63. Thin-walled beaker; flat base fragment. Pl. 16/8.

Dm. 31 mm, H. 13 mm, Th. 2 mm. Fine reduced fabric of grey colour, shiny black slip.

North Italy (?), c. beginning of 2nd century AD.

Barracks no. 2; X. 2 m, Y. 13 m, d. 0.8 m.

Inv. no. 413/1973, Mus. Zalău.

64. Lead-gazed beaker; base fragment with footring. Pl. 16/9, 19/8.

Dm. 39 mm, H. 15 mm, H. 15 mm, Th. 4 mm. Green lead-glaze.

Barracks no. 1; X. 38–40 m, Y. 0–4 m, d. 0.8 m.

Nr. inv. 644/1973, Mus. Zalău.

65. Lead-gazed bowl; rim fragment. Pl. 16/10.

Dm. 160 mm, H. 17 mm, Th. 5 mm. Green lead-glaze.

Barracks no. 2; 'close to the *via sagularis*', i.e. in the centurion's quarter.

Inv. no. 517/1973. Mus. Zalău.

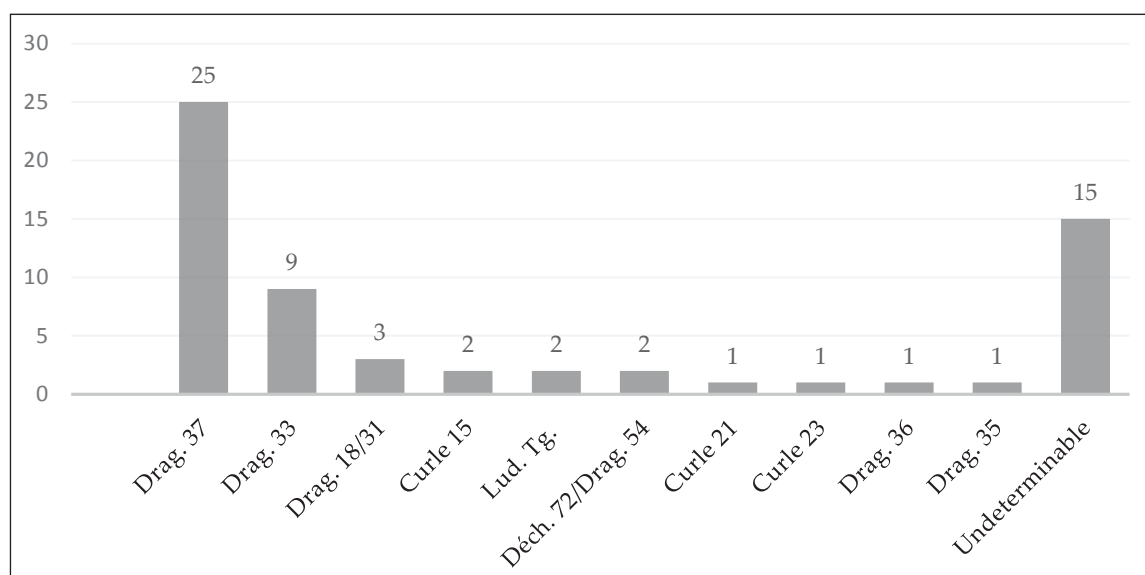

Figure 14. The distribution of forms within the category of terra sigillata.

³⁸² Gudea 1995, 116, 120, Abb. 3.

³⁸³ Gudea 1995, 119, Abb. 2.

³⁸⁴ Hayes 1997, 65.

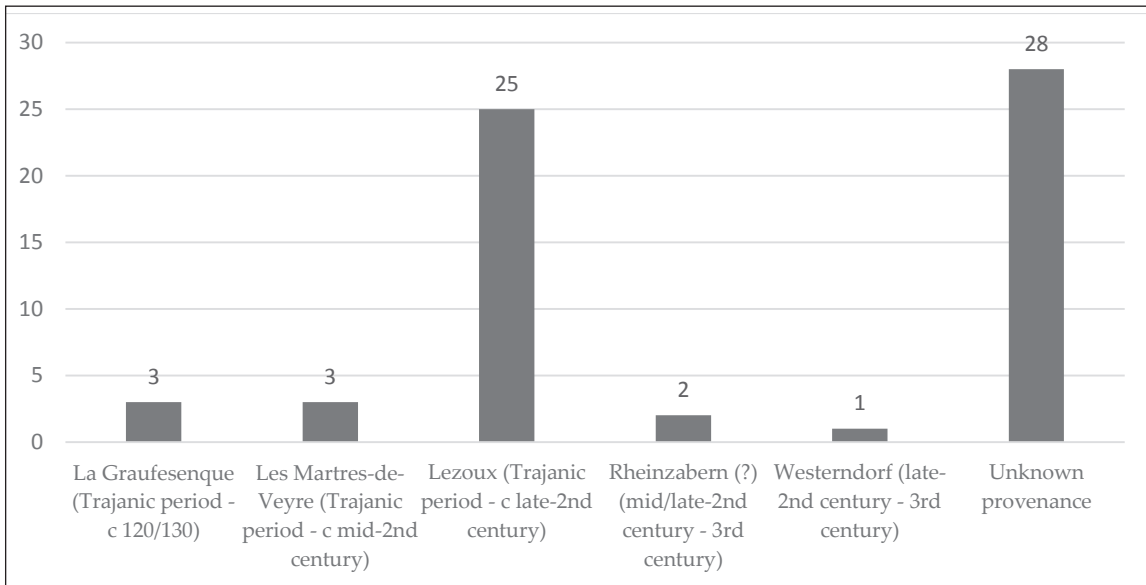

Figure 15. The distribution of the terra sigillata vessels according to production centres.

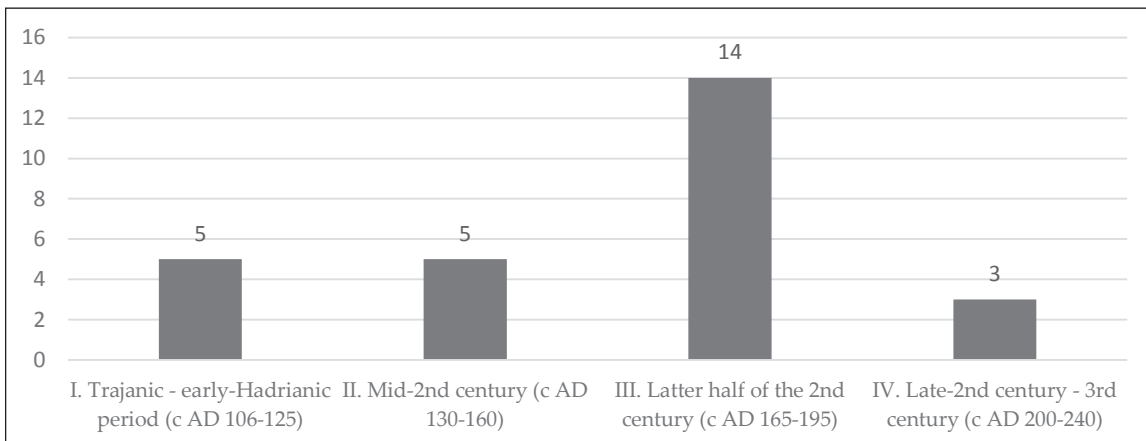

Figure 16. The chronological distribution of the terra sigillata vessels.

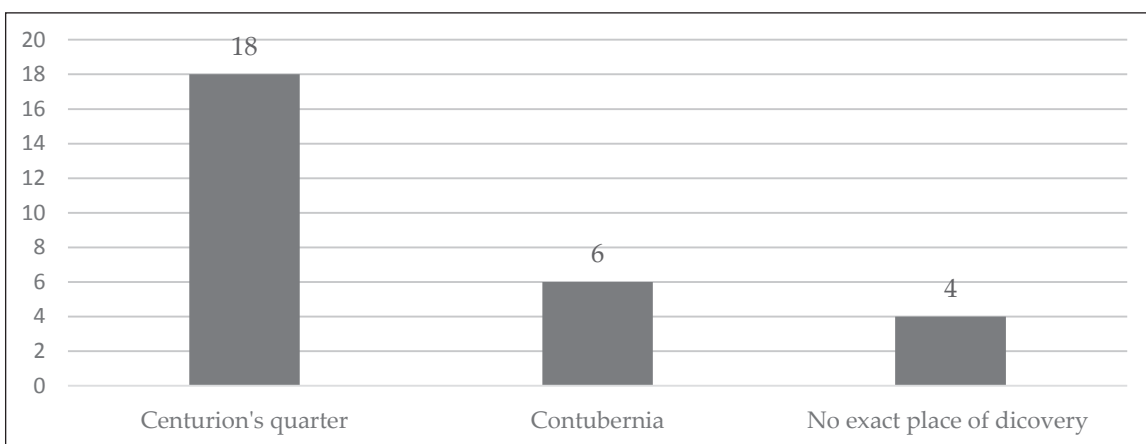

Figure 17. The spatial distribution of the terra sigillata vessels discovered in Barracks no. 2.

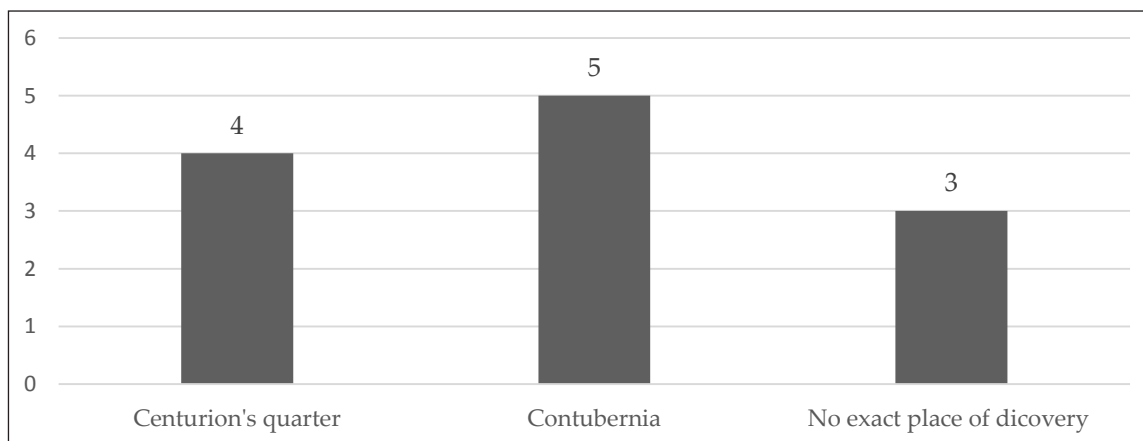

Figure 18. The spatial distribution of the terra sigillata vessels discovered in Barracks no. 1.

4.2.2. *The utilitarian ware (including the amphorae)*

4.2.2.1. *The local production*

The present category comprises a wide range of ceramic containers with varied functionalities. The common denominator in this case is the ancillary role played by the vessels belonging to this category in both the process of food preparation (beginning with the stages of transport and storage) and consumption (serving). Accordingly, the category comprises transport vessels conventionally identified with amphorae, used for the acquirement of certain staple foods, and storage vessels identified with *dolia* and the smaller *seriae*, generally used for the storage of a wide range of foodstuffs. It is highly likely that transport and storage was not limited to the two aforementioned vessel types, and certain types of jars and jugs were also involved in both processes, however at this stage the precise assessment of this situation is unfeasible, although the argument that certain types of large jugs were primarily used for the storage of various liquids such as water, wine, or olive oil will be put forward below. Within this category, the amphorae are the only class consisting of imported vessels, all other classes admittedly comprising locally produced containers. A further subset of this category consists of vessels employed in the food preparation processes which did not require the use of thermal treatment, such as *mortaria*, or strainers. The final group is that of the vessels employed for storing and transferring liquids both during food preparation and for serving drinks.³⁸⁵

From a functional point of view, just slightly above half the recipients of this category consist of vessels used for storage and transfer of liquids, i.e. jugs and flagons (Figure 19), while *dolia* account for a quarter of the group. The low proportion of *mortaria* is somewhat surprising, especially given the affinity of military communities for this vessel type.³⁸⁶

1) Jugs (JU)

Jugs are defined as tall closed recipients with an ovoid body, relatively wide mouth opening, well-defined and wide neck, and usually one, occasionally two ribbed handles, lending them amphora-like features. Instances of two-handled jugs are sometimes referred to as 'table amphorae' in the pottery literature.³⁸⁷ Given that these vessels were primarily used for the storage of liquids, one of the most crucial morphological traits setting them apart from similar classes, is the wide neck and mouth opening. This feature facilitated the access to the contents, either by pouring or

³⁸⁵ Rusu-Bolindeț 2007, 423.

³⁸⁶ Junkelmann 1997, 99; Cool 2006, 43.

³⁸⁷ Opař 1996, 39–41.

ladling, usually with a *simpulum*.³⁸⁸ Furthermore, in accordance with their primary function, and based on the rim and neck fragments preserved, their overall dimensions must have exceeded all similar classes. In the present case the mouth openings of the vessels ascribed to this category range between 80 and 350 mm.

Catalogue of forms:

JU 1 (Pl. 20/1). Horizontal reeded rim, rounded lip, slightly biconical neck with a horizontal groove in its centre. Fabric type: OS 1 both with and without colour-coating. Only two examples. Similar rims are featured on certain three-handled jugs published in the 1972 monograph (Figure 20).³⁸⁹

JU 2 (Pl. 20/2). Slightly everted reeded rim, rounded lip. The main fabric types: OS 3 (the overwhelming majority) and OS 1. Around half of the fragments display colour-coating.

JU 3 (Pl. 20/3). Horizontal thickened rim ('pulley rim'), rounded lip, similar to Gaulish amphorae.³⁹⁰ Fabric types: OS 3 and RF 1, occasionally with colour-coating.

JU 4 (Pl. 20/4). Vertical thinned and reeded rim, apparently no neck, bilobate handle attached to the body and rim. Fabric type: RS 1. Only one example can be ascribed to this type.

JU 5 (Pl. 20/5). 'Water jug'. Everted rim connected directly to the neck, angular lip, and flat handle. Fabric type: OC 2 (exclusively), mostly without colour-coating.

JU 6 (Pl. 20/6). Everted and slightly flanged, thickened and profiled rim. Rounded lip. Flat handle. Fabric types: OS 3.

JU 7 (Pl. 20/7). Everted and thickened rim with horizontal reeding. The dominant fabric types: OS 3, mostly with colour-coating. Similar rims are featured on certain two-handled jugs published in the 1972 monograph (Figure 20).³⁹¹

JU 8 (Pl. 21/1). Possible 'local amphora', everted rim, with large horizontal groove, lid-seating and flat ribbed handle. Fabric type OS 3 with brownish red colour-coating applied with a brush. Only one example can be ascribed to this type.

JU 9. (Pl. 21/2). Everted, funnel-like rim with large horizontal groove on the exterior, and lid-seating on the inside. No traces of the handles are preserved. Fabric types: OS 1 and OS 3.

JU 10 (Pl. 21/3). Slightly everted flanged rim with internal groove, long thick neck. No traces of the handles are preserved. Fabric types: OS 2 and RC 3, no colour-coating. Only two examples, very wide mouth opening (320–350 mm).

2) Flagons (FL)

This class comprises closed tall vessels, usually with long narrow neck, ovoid body, footring at the base and one or rarely two handles.³⁹² The features which set them apart from the jugs are: the

³⁸⁸ Rice 1987, 241.

³⁸⁹ Chirilă et al. 1972, Pl. XXVIII/1.

³⁹⁰ Ciaușescu/Mustața 2009, 248, Pl. I/2.

³⁹¹ Chirilă et al. 1972, Pl. XXVIII/6.

³⁹² Rusu-Bolindeț 2007, 423.

narrower neck and mouth opening, the footring (occasionally occurring on jugs as well) and their overall smaller dimensions. Presumably these are containers employed for the transport of liquids to the table and for transferring the contents into drinking vessels. The long and narrow neck can help prevent spilling during transport and also facilitate direct pouring into drinking vessels.³⁹³ As mentioned above, flagons can be considered small and medium sized vessels, the mouth opening of the fragments within the present assemblage ranging between 25 and 160 mm. It cannot be excluded that some forms were used directly for drinking (Figure 21/1).

Catalogue of forms:

FL 1 (Pl. 21/4). Everted, thinned rim, rounded lip, large horizontal ridge on the exterior. The traces of the handle were not preserved. Fabric type: OS 3, both with and without colour-coating.

FL 2 (Pl. 21/5). Everted rim, external horizontal groove, rounded lip. Probably imitation of a bronze flagon type. Fabric type: OS 3, both with and without colour-coating.

FL 3 (Pl. 22/1). Everted rim with lid-seating, triangular thickened lip, narrow vertical groove on the exterior at the base of the rim. Fabric type: OS 1 without colour-coating. Only one example can be ascribed to this type.

FL 4 (Pl. 22/2). Everted rim, rounded lip, two horizontal grooves on the exterior, thin walls. Fabric type: OS 1, OS 3, and OS 4, both with and without colour-coating.

FL 5 (Pl. 22/3). Cupped-mouth flagon, slightly everted rim, angular lip, lid-seating (for stopper). Fabric type: OS 3 and RF 1.

FL 6 (Pl. 22/4). Everted rim, triangular lip, narrow mouth opening (25–40 mm). Fabric types: OS 2 and OS 3, usually with brownish red colour-coating.

FL 7 (Pl. 22/5). Everted, funnel-shaped rim, rounded and thinned lip. Fabric types: OS 3 and OC 2 (!), both with and without colour-coating.

FL 8 (Pl. 22/6). Vertical walls, slightly everted rim, rounded lip. Fabric type: OF 2, brown colour-coating. Only one vessel belongs to this category.

FL 9 (Pl. 22/7). Vertical rim, beaded and slightly outcurved lip. Only one vessel belongs to this category made from reduced fabrics (RS 1) with black colour-coating.

3) *Dolia* and *seriae* (DO)

The vessels designated with the term *dolia* are usually associated with containers used for preserving various foodstuffs, primarily wine, olive oil, and cereals.³⁹⁴ Based on the written record, smaller sized *dolia* were known as *seriae* (singular: *seria*)³⁹⁵ however for the sake of clarity, and due to the fact that clear morphological differences cannot be asserted between the two, no division will be applied with regard to the present assemblage, even though the argument could be made

³⁹³ Rice 1987, 241.

³⁹⁴ Opaïț 1996, 37–38; Hayes 1997, 35–36.

³⁹⁵ Peña 2007, 20, 125, 369, note 6; with regard to Roman Dacia see Ciaușescu/Mustață 2009, 246–249, pl. VII/6, VIII, XII/5.

that some forms can be interpreted as being *seriae* based on their reduced dimensions. It also must be underlined that extremely large *dolia* are quite rare in Roman Dacia, commonly the finds of this class belonging to the medium and small categories. From a morphological point of view, the *dolium* is defined by a neckless globular or ovoid closed body, and very thick flanged rims either attached to the shoulder of the vessel or outplayed. Some forms display a neck (albeit very short) rendering them somewhat similar to pots. The considerable variations in size are reflected by the wide spectrum of mouth opening diameters ranging between 130 and 450 mm. Only two *dolia* are illustrated in the 1972 monograph, both seemingly intact, one displaying an unusual form with two attached loop handles and a somewhat pot-shaped body, while the other one is decorated with engobe patterns consisting of wavy and straight lines, its dimensions (Dm. 120 mm, H. 330 mm) indicating that we are dealing in fact with a *seria* (Figures 20/5, 21/5).³⁹⁶

Catalogue of forms:

DO 1 (Pl. 23/1). Outsplayed thickened rim, rounded lip, globular shoulder. Fabric types: OS and OS 4, with no colour-coating.

DO 2 (Pl. 23/2). Thickened outcurved rim, rounded lip, globular shoulder. Fabric type: OS 2, without colour-coating. Only one example can be ascribed to this type.

DO 3 (Pl. 23/3). Horizontal thickened rim ("T-shaped"), rectangular lip. Fabric type: OS 1, OS 2, OS 3, RS 1, without colour-coating.

DO 4 (Pl. 23/4). Inturned thickened rim, triangular lip, globular shoulder. Fabric types: OS 1, OS 3, RS 1, OF 1 (!), no colour-coating.

DO 5 (Pl. 23/5). Outcurved thickened rim, angular lip and lid-seating. Fabric types: RC 3, no colour-coating.

DO 6 (Pl. 23/6). Outsplayed, thickened reeded rim. The mouth opening is 160 mm. Fabric: OS 3. Only one example can be ascribed to this type.

4) Jars (JA)

The category comprises small beaker-sized vessels of forms similar to the class of pots, made from coarse fabrics, which were probably employed for storing small quantities of foodstuffs, or ground spices. Besides the fabrics, a further indication of their functionality is the lack of colour-coating. Furthermore, the fragments do not display any signs of sooting, ruling out thus the possibility that we are dealing with small sized cooking pots. A groups of jars are included in the monograph (Figure 22). The respective vessels (included in the category of pots) are reported to have coarse fabrics and display heights of around 100–150 mm and mouth openings of around 100 mm.³⁹⁷

JA 1³⁹⁸ (Pl. 22/8). Everted, funnel-shaped rim, rounded lip and lid-seating; the shoulder is marked by repeated parallel grooves and ridges; the body has an ovoid shape, the base is flat. One single intact vessel can be ascribed to this type (Dm. 79 mm, H. 98 mm, Th. 7 mm). The fabric is OC 2. The

³⁹⁶ Chirilă et al. 1972, Pl. XXVII/5, XXVIII/5.

³⁹⁷ Chirilă et al. 1972, 43, no. 1–2, 4–7, Pl. IV (same numbers).

³⁹⁸ The vessel was earlier considered to be a miniature vessel, see Petruț 2015.

vessel displays signs of secondary burning on one of its sides which are not consistent with the sooting resulted from cooking.

JA 2 (Pl. 22/9). Everted rim, rounded lip, external horizontal groove at the middle of the rim. Only one container belongs to this type, the fabric is coarse (OC 2) with no colour-coating.

JA 3 (Pl. 22/10). Slightly everted rim, rounded lip. Roulette decoration on the body. Fabric type: RC 3, with no colour-coating. Only one example can be ascribed to this type.

JA 4 (Pl. 22/11). Everted and thickened rim, narrow and high neck. The fabric is fine: RF 1, with no colour-coating. Only two examples.

5) Strainers (cheese-presses)

The containers with evenly spread *ante cocturam* perforations in their walls are usually designated with the somewhat ambiguous term 'strainers'. Given their elusive functionality and their relatively low numbers within the assemblages, usually little attention is paid to them in the pottery reports.³⁹⁹ The most common view with regard to their functionality is that they were involved in dairy processing as cheese-presses.⁴⁰⁰ This is in fact the most likely possibility put forward thus far, and confirmed by chemical analysis which found milk residues in the walls of vessels with perforated walls from Britain.⁴⁰¹ Still, the term cheese-press implies a very individualized and precise functionality which involves certain risks as there is no certainty that examples from Dacia were used in the same manner as the ones from Britain, as usually most vessels were used in more than one way despite having a principal functionality. For this reason, the somewhat neutral term of strainer will be employed here. With regard to the material from Roman Dacia, some studies have asserted in the past the possibility that we might be dealing with ceramic copies of metal vessels, their functionality corresponding with that of the prototypes.⁴⁰² Considering however that the drainage holes on the pottery vessels have diameters up to 5 mm, it is unlikely that they were suitable for straining the spiced wine as many impurities would have ended up in the drinking vessels. The analysis of the assemblage from the military works-depot at Longthorpe in Britain has highlighted in addition to the well-known disc-shaped presses, hemispherical and conical types as well.⁴⁰³ The latter two forms are also known from continental sites.⁴⁰⁴

From the four fragments present in the assemblage under scrutiny here, three can be determined in terms of forms, even though in two cases only the bases are preserved. Relying on the analogy of the Longthorpe material, these can only be ascribed to the conical type, even though one is fitted with a footring while the other one has a flat base (see below ST 2). Based on the insight provided by the abovementioned site, it seems likely that due to the fragmentary nature of the material, a large amount of strainers cannot be recognized as such, many examples displaying a low number of drainage holes towards the base of the vessel.⁴⁰⁵

³⁹⁹ Cool 2006, 95–96.

⁴⁰⁰ Dannell 1987, 151–153.

⁴⁰¹ Cool 2006, 95, note 14.

⁴⁰² Rusu-Bolindeț 2007, 415–416.

⁴⁰³ Dannell 1987, 151–153, types 65–67, fig. 41; Cool 2006, 96, figure 10.1.

⁴⁰⁴ Dannell 1987, 151; Junkelmann 1997, 99, Abb. 48.

⁴⁰⁵ Dannell 1987, 148, Fig. 41.

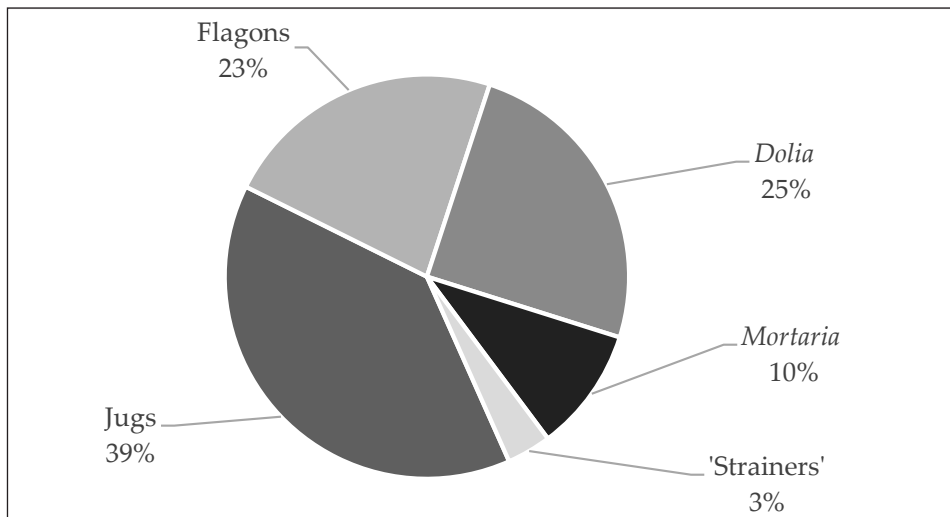

Figure 19. The distribution of vessel classes within the category of utilitarian ware.

Catalogue of forms:

ST 1 (Pl. 24/2). Hemispherical (bowl-like) vessel, everted and thickened rim, rounded lip, possible lid-seating. Fabric type: RC 2, without colour-coating. Only one example can be ascribed to this type.

ST 2 (Pl. 24/3–4). Conical strainer. Only the base is preserved. Fabric types: OS 2 and OS 3, without colour-coating.

6) *Mortaria* (MO)

This category comprises the hemispherical bowls with flanged rims and usually with gritty interior surface, used for crushing various herbs and spices and mixing sauces. The mouth-openings of the vessels range between 220 and 330 mm.

MO 1 (Pl. 24/5). Horizontal thinned rim, rounded lip, large outcurved flange attached to the rim. Fabric type: OF 1 with orange colour-coating. Only one example can be ascribed to this type.

MO 2 (Pl. 24/6). Vertical rim with external horizontal ridge, slightly carinated body, large outcurved flange attached below the rim. Fabric type RS 1 without colour-coating. Only one example can be ascribed to this type.

MO 3 (Pl. 24/7). Vertical thinned rim with external horizontal groove, outcurved thick flange attached below the rim. Fabric types: OS 2, OS 3, OF 1, and RS 1, both with and without colour-coating. The overwhelming majority of fragments belongs to this type.

4.2.2.2. *The amphorae*⁴⁰⁶

Up to this point not a single amphora fragment from the Buciumi assemblage was published. The reasons are probably multiple, a principal determining factor must be the very incipient level of research regarding the amphorae from Roman Dacia. Indeed, the number of published amphorae throughout the province is very low.⁴⁰⁷ Altogether only five such vessels were identified

⁴⁰⁶ I wish to thank dr. Tamás Bezczy (Österreichische Akademie der Wissenschaften) for the help provided in determining some of the fragments discussed below.

⁴⁰⁷ Ardeț 2006.

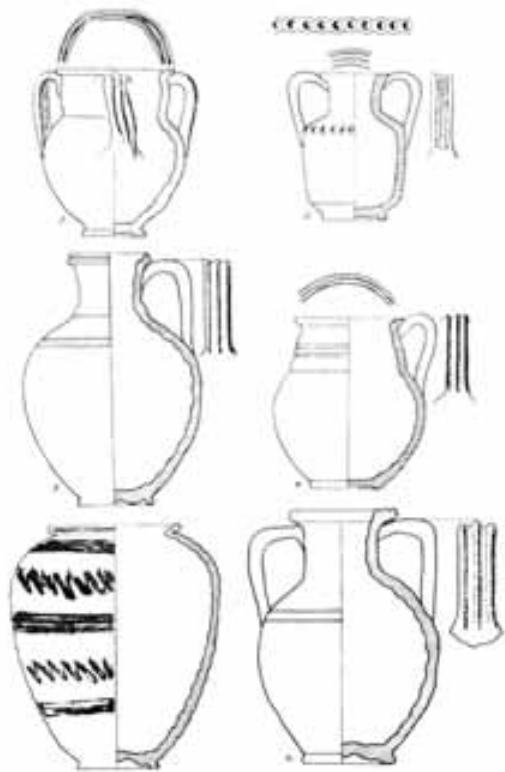

Figure 20. Jugs and storage vessels published in the 1972 monograph.



Figure 21. Jugs and storage vessels published in the 1972 monograph.

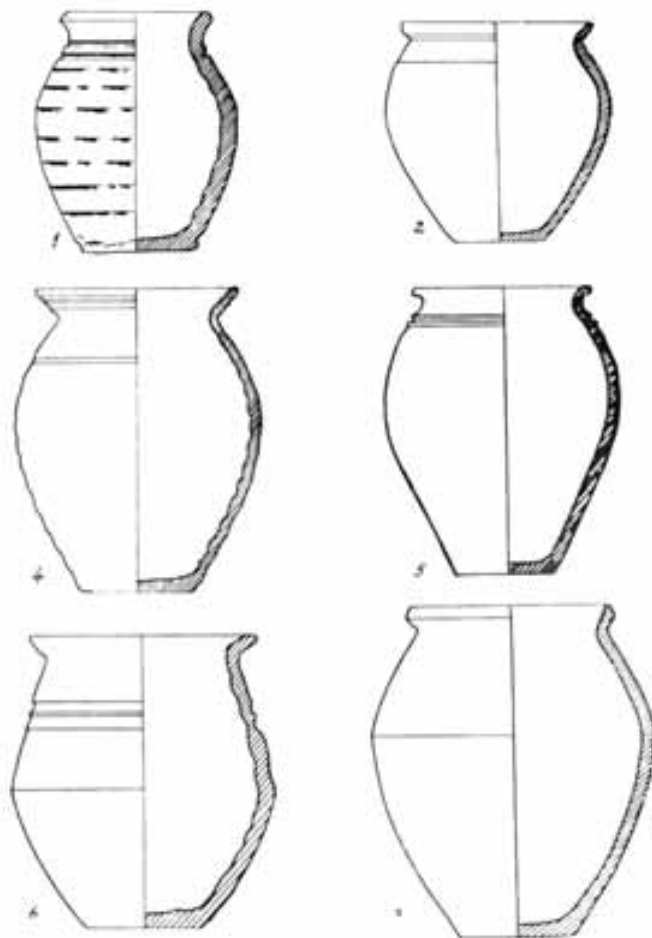

Figure 22. Jars/pots published in the 1972 monograph.

in the assemblage, two belonging to the Dressel 6B type, two to the Dressel 24/Zeest 90 form, and one to the so-called Aquincum 78 (Figure 23).

1) Dressel 6B Istrian amphorae

This type is linked with olive oil producers based on the Istrian Peninsula (*'oleum histrici'*) in Regio X Venetia et Histria in Italy,⁴⁰⁸ and is characterized by a funnel-shaped rim and ovoid body. Production of this form started in the 1st century BC in Italy and lasted until the late Hadrianic period, when the Istrian oil production dropped dramatically, its exports reaching a minimal level.⁴⁰⁹ It has to be mentioned however that in the auxiliary fort at Carnuntum some of the Dressel 6B amphorae were discovered in contexts dated to the Marcomannic Wars and even to the 3rd century.⁴¹⁰ The finds from Dacia are usually dated to the early-2nd century.⁴¹¹ The amphora workshops were most likely owned by the olive-oil producers, as was the case with the most important complexes of the peninsula belonging to the Laecanius family, the most well-known being the one at Fasana, in modern-day Fažana, owned by senator C. Laecanius Bassus.⁴¹² The primary content transported in these amphorae was thus olive oil, although in some exceptional cases the *tituli picti* indicate wine as a content.⁴¹³ The main market for the Istrian olive oil was Italy and the Danubian provinces of Pannonia and Noricum, while major consignments of Dressel 6B amphorae are known from the shipwrecks in the Adriatic.⁴¹⁴ In Roman Dacia, the number of amphorae finds of this type is relatively low, most of them coming from Upper and Lower Dacia.⁴¹⁵

The current assemblage includes a rim fragment (66) in addition to a fragment coming from the vessel's neck and handle (67). The former displays a horizontal groove under the rim, accounting for a somewhat rare feature for this type. The existence of similar inconsistencies is quite common however even in the case of vessels coming from the same workshop.⁴¹⁶ Unfortunately, the respective fragment was subjected to intense secondary burning which altered the features of the fabric. With regard to the second fragment, the form of the neck and of the handle, as well as the intense brick red fabric with calcite and quartz inclusions clearly indicates its affiliation with the type Dressel 6B.

2) The Dressel 24/Zeest 90 amphorae

The somewhat elusive type comprises a group of related forms affiliated to various degrees with-, or as subsets of type Dressel 24, also known in the literature as Zeest 90 or Knossos 15.⁴¹⁷ The defining morphological features of the type include the high funnel-shaped rim, long conical neck and ovoid body.⁴¹⁸ Based on its distribution map, the type was most likely produced either in the North-Aegean region or somewhere on the Black Sea coast.⁴¹⁹ It is also possible that the type

⁴⁰⁸ Peacock/Williams 1986, 98–100 (Class 8 C); see also Bezeczky 1998, 3–43 for the historical context of Istrian olive oil production.

⁴⁰⁹ Bezeczky 1998, 10–11.

⁴¹⁰ Bezeczky 1997, 148–149.

⁴¹¹ Peacock/Williams 1986, 100; Ardeț 2006, 69.

⁴¹² Bezeczky 1997, 149; Bezeczky 1998, 3–43.

⁴¹³ Bezeczky 1998, 5–6.

⁴¹⁴ Jurišić 2000, 11–12.

⁴¹⁵ Ardeț 2006, 69.

⁴¹⁶ Bezeczky 1998, 6–12.

⁴¹⁷ Auriemma/Quiri 2004, 49–50, fig. 10.

⁴¹⁸ Dyczek 2001, 176 (type 25); Ardeț 2006, 106.

⁴¹⁹ Dyczek 2001, 174; Ardeț 2006, 107.

was produced in a number of workshops based in the Eastern Mediterranean as well as the Black Sea coast.⁴²⁰ According to the evidence of the *tituli picti*, the most common product transported in these amphorae was olive oil, although in some case the inscriptions indicate wine and *garum* as well.⁴²¹ The type is quite common throughout the 2nd–3rd centuries AD, accounting for most amphorae finds in Roman Dacia.⁴²²

Two fragments in the present assemblage can be ascribed to this type. Although the two clearly belong to the aforementioned form, some differences can be noted with regard to form and fabrics. Fragment no. **69** displays a shorter rim which is thickened and rounded, rendering it somewhat similar to Dressel 6 amphorae. The semifine pale brick red fabrics with frequent calcite inclusions is however typical for Dressel 24/Zeest 90 amphorae. Fragment no. **68** on the other hand displays a higher rim with straight conical walls and angular lip, as opposed to the rounded lip of the previous fragment. The fabric is similar to the previous fragment, although it is covered in a white coating possibly indicating the use of sea water in its production.⁴²³ These particularities may either indicate differences in the place of production or of chronological nature, the former being more plausible.

3) Aquincum 78 amphorae

The respective type was defined by Tamás Bezczky in the interpretation of an assemblage from the residence of the *tribuni laticlavi* in the legionary base in Aquincum.⁴²⁴ From a morphological point of view the type displays a general similarity with the Dressel 6B form, however numerous differences justify its classification as a separate type, such as its relatively small overall dimensions, the angular base of the funnel-shaped rim, and the *ante cocturam* incised wavy line on the rim, which seems to be a hallmark of this type.⁴²⁵ Furthermore, the fabric is compact and displays a yellowish colour. The type has a wide occurrence in Pannonia roughly covering the distribution pattern of Dressel 6B, although neither the place of production nor the standard content of these amphorae could hitherto be established. The chronological framework of the finds is estimated to comprise the period between the late-1st century and the latter part of the 2nd century AD.⁴²⁶ Possible indications regarding the products usually transported in these amphorae can be deduced from the analysis of an assemblage of a ship-wreck discovered in the Adriatic. According to Bezczky's assertion, the possible Aquincum 78 amphorae included in the respective material appear to indicate a consignment of *liquamen* from Hispania.⁴²⁷ The fragment belonging to the Buciumi assemblage is so far the only one of this type reported in Roman Dacia, although considering the similarities with the type Dressel 6B, it is possible that at least in some cases the finds were incorrectly classified.

4) The supply of amphora-borne commodities to the fort

Earlier the point was made that the amphora finds from the military environment of Dacia are quite rare. The present assemblage seems to corroborate this situation. The technical aspects which account at least in part for this setting, i.e. the lack of awareness of amphorae in older reports, and

⁴²⁰ Auriemma/Quiri 2004, 49.

⁴²¹ Dyczek 2001, 192.

⁴²² Ardeț 2006, 107.

⁴²³ Peacock/Williams 1986, 45.

⁴²⁴ Bezczky 2005, 63–65.

⁴²⁵ Bezczky 1997, 170, 178; Bezczky 2005, 63.

⁴²⁶ Bezczky 1997, 178; Bezczky 2005, 63.

⁴²⁷ Bezczky 2005, 65.

the scarcity of amphorae studies dealing with finds from Dacia, are probably insufficient arguments for the low number of finds across the province. As shown in Chapter 1, there is usually some exaggeration in the claims regarding the indispensable nature of wine and olive oil in the soldiers' rations all across the Empire. Instead, soldiers' rations should be viewed as being flexible and adapted to a certain degree to the geographical environment in which the respective unit was stationed. Even so, the supply of amphora-borne commodities must have been quite consistent in some parts of the Empire as indicated by their presence in the military ceramic assemblages published from sites across Central and North-Western Europe,⁴²⁸ and probably less so elsewhere. This hypothesis is so far corroborated by the analysis of amphora-finds from the military environment of Pannonia, which revealed considerably lower numbers relative to similar sites from the western part of the continent.⁴²⁹ It might be deduced from this data that the proportion of officers and soldiers who could afford such products probably varied from one region to another, given that both Pannonia and Dacia lack consistent quantities of amphorae.⁴³⁰ The reasons are probably both economic and cultural as indicated by the chronological distribution of the Pannonian finds, with the highest occurrence dated to the transition between the 1st and 2nd century AD, when presumably the majority of the officers stationed in the Province were of Italian origin.⁴³¹ It is highly likely that these officers were regular consumers of amphora-borne commodities. Furthermore, there is no reason to assume that locally recruited regular soldiers would have preferred olive oil over lard.⁴³²

The bulk of the wine supply, which by all accounts must have reached considerable proportions, was most likely carried out at a local or regional level, transported in barrels, rather than through long-distance trade. Despite the obvious difficulties of assessing the supply of wine transported in barrels, some indirect evidence can be cited here. In the case of the fort at South Shields on Hadrian's Wall, the nearly total absence of wine amphorae during the course of the 2nd and 3rd centuries AD was explained through the massive influx of Rhenish wine transported in barrels, which replaced the much more expensive South Gaulish wine regularly imported until then.⁴³³ The situation is, as it seems, similar throughout the forts of Northern Britain. A further problem is the one raised by D.P.S. Peacock and D.F. Williams with regard to the fact that despite the advanced state of amphora research, there is no certainty that some types of jugs were also not regularly used for the transport of wine.⁴³⁴

Although in the absence of a comprehensive study carried out on the finds of several forts in Dacia it is impossible to draw any firm conclusions with regard to the supply of amphora-borne commodities in the military environment of the respective province, the two models outlined above, from Pannonia and Northern Britain, can potentially explain the situation from Buciumi. This is suggested both by the small number of amphorae within the assemblage as well their nature. Apart from the fragment belonging to the type known as Aquincum 78, the rest of the material comprises amphorae typically used for the packaging and transport of olive oil. Furthermore, although the exact dating of some types is uncertain, the presence of two fragments belonging to the type Dressel 6B which remained in use only until the late-Hadrianic period⁴³⁵ seems to corroborate the notion that olive oil was imported at a more intense pace during the early stages of the

⁴²⁸ Williams 1994.

⁴²⁹ Bezeczky 1997, 147–178 (the auxiliary fort at Carnuntum); Bezeczky 2005, 35–108 (the legionary fortress at Vindobona).

⁴³⁰ Bezeczky 2005, 69.

⁴³¹ Bezeczky 2005, 70.

⁴³² Bezeczky 2005, 70.

⁴³³ Williams 1994, 216; see Opař 2004, 90, with regard to the question of wine transported in barrels.

⁴³⁴ Peacock/Williams 1986, 5.

⁴³⁵ Given the similar distribution patterns of Aquincum 78 amphorae in Pannonia, it is likely that the same chronology can be applied to this type as well.

fort's occupation. Although the small size of the material effectively thwarts its representativity, it still has to be mentioned that all fragments were discovered in the centurion's quarter of barracks no. 2, which could potentially indicate that we are dealing with the personal provisions of the centurion or other members of the *principales*.

The finds catalogue:

66. Dressel 6B amphora. Rim fragment. Pl. 25/2; 26/2.

Northern Italy (the Istrian Peninsula). Dating: early-1st century AD–the Hadrianic period.

Unpublished. Dm. 160 mm, H. 54 mm, Gr. 10 mm.

A thin vertical groove can be seen on the rim. The fragment displays signs of strong secondary burning. The fabric is semifine (the colour was altered by the secondary burning), inclusions: frequent mica and moderate calcite grains (1–2 mm).

Barracks no. 2; 'next to the *via sagularis*', i.e. in the centurion's quarter.

Inv. no. 632/1973. Mus. Zalău.

67. Dressel 6B amphora. Rim and neck fragment. Pl. 25/3; 26/3.

Northern Italy (the Istrian Peninsula). Dating: early-1st century AD–the Hadrianic period.

Unpublished. Dm. 120 mm, H. 78 mm, Th. 14 mm, Lg. 100 mm.

The fabric is semifine, of intense brick red colour; inclusions: moderate small calcite grains, moderate iron oxide (2–4 mm).

Barracks no. 2; X. 50–54 m, Y. 5–5.5 m, d. 0.8 m (inside the centurion's quarter).

Inv. no. 716/1973.

68. Zeest 90/Dressel 24 type amphora. Rim fragment. Pl. 25/4; 26/4.

Uncertain provenance. Dating: 2nd–3rd centuries AD.⁴³⁶

Unpublished. Dm. 190 mm, H. 104 mm, Th. 9 mm.

The fabric is coarse, of brick-red colour with yellowish colour-coating.

Barracks no. 2; X. 43–53 m, Y. 0–5.5 m, d. 0.8–1.5 m. 'Next to the *via sagularis*' (inside the centurion's quarter).

Inv. no. 403/1973. Mus. Zalău.

69. Zeest 90/Dressel 24 type amphora. Rim fragment. Pl. 25/5; 26/5.

Uncertain provenance. Dating: 2nd–3rd centuries AD.

Unpublished. Dm. 120 mm, H. 75 mm, Th. 9 mm.

The fabric is semifine, of pale brick-red colour; inclusions: frequent small calcite grains.

Barracks no. 2; X. 44–47 m, d. 0.7 m.

Inv. no. 649/1973. Mus. Zalău.

70. Aquincum 78 type amphora. Rim fragment. Pl. 25/1; 26/1.

Uncertain provenance. Dating: mid-1st century AD–latter half of the 2nd century AD.⁴³⁷

Unpublished. Dm. 110 mm, H. 80 mm, Th. 9 mm.

A vertical wavy groove is present on the rim of the amphora. The fabric is semifine, of yellowish colour, without colour-coating.

Barracks no. 2. 'Next to the *via sagularis*', i.e. in the centurion's quarter.

Inv. no. 405/1973. Mus. Zalău.

⁴³⁶ Dyczek 2001, 193.

⁴³⁷ Bezeczky 2005, 63.

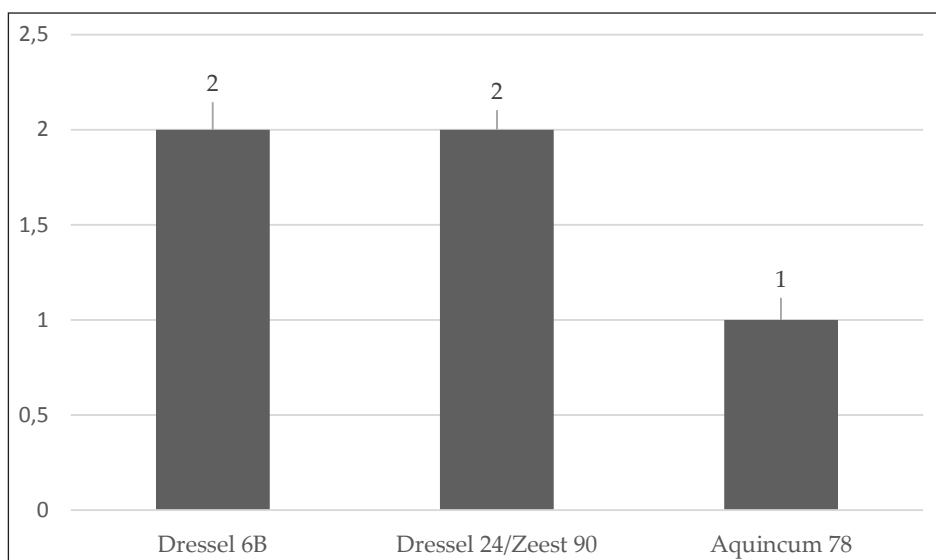

Figure 23. The distribution of amphora types.

4.2.3. The cookware

This category comprises wheelthrown vessels employed for preparing meals on various types of heat sources. Due to the specific technological characteristics required of vessels used in direct contact with fire, this section will only deal with containers that were potentially used for boiling, steaming, baking, roasting, frying, etc. various types of foods. As already mentioned above, some forms encountered within the present category have variants produced in fine or semifine fabrics (sometimes with colour-coating), indicating a totally different functionality, such as the pans and jars (see above). The cookware category consists of: pots, casseroles (carinated bowls), and pans, admittedly all of local origin.

The European part of the Empire saw the emergence of three main Italian type cooking vessels: the pot (*olla, aulā*), the casserole (*caccabus*), and the pan (*patina, patella*).⁴³⁸ In the Italian Peninsula the three categories were used together over a long period of time, although the changes ensued in the culinary habits caused oscillations in their degree of use. It is claimed that the employment of pots decreased by the start of the 1st century AD together with the drop in the preference for mush dishes and the increase in popularity of casseroles and implicitly of stews and fried foods.⁴³⁹ Conversely, the use of pans seems to be maintained at a constant level.

The distribution of classes within this category reveals that over half of the cooking vessels are represented by pans, the proportion of casseroles being the lowest of the three (Figure 24). Given the high number of pans and pots, as well as the fact that they were clearly used for the preparation of different types of meals, it is possible that the two vessel types were assigned to complementary purposes within cooking sets, possibly together with certain metal containers.

1) Pots (PO)

The category comprises relatively tall vessels with ovoid bodies, short necks, large or medium mouth openings, flat bases (of lesser diameter than the mouth opening), everted rims, and no handles. The fabrics are overwhelmingly coarse, displaying larger than average inclusions, while colour-coating is extremely rare. Pots are usually the most common types of cookware within the ceramic assemblages of Roman Dacia. Unfortunately, this class appears in the present assemblage

⁴³⁸ Meylan-Krause 2002, 123–124.

⁴³⁹ Meylan-Krause 2002, 123.

exclusively by small fragments which hinders the assessment of the complete form of the vessels. All the same, the morphology of the rims is especially varied. With regard to the dimensions of the vessels, the sole indicator is the diameter of the mouth opening, which in this case ranges between 100 mm and 300 mm, but in the overwhelming majority of cases is situated below 200 mm (Figure 36). Some types (PO 1–3, PO 6) feature lid-seating, prominent shoulders and necks, a feature ascribed to the Mediterranean tradition, or so-called ‘Romanized’ forms,⁴⁴⁰ also termed as *Militärkochtöpfe*,⁴⁴¹ while others seem to display the influences of a Late Iron Age tradition (PO 4–5, PO 7).

Catalogue of forms:

PO 1. (Pl. 27/1). Everted rim with rounded lip and lid-seating. The fabrics are overwhelmingly oxidized types, mostly: OC 2 and OC 3. The mouth opening ranges between: 110 mm and 150 mm.

PO 2 (Pl. 27/2). Everted and thinned rim with lid-seating. The mouth opening ranges between 120 mm and 180 mm. Fabric types: OC 1, OC 2, OC 3, OC 4, and OC 5.

PO 3 (Pl. 27/3). Everted and thickened rim, subangular lip, with lid-seating. The mouth opening ranges between 120 mm and 140 mm. Fabric types: RC 3, OC 3, OC 4, and OC 5.

PO 4 (Pl. 27/4). Everted and thickened rim, rounded lip. The mouth opening ranges between 120 and 180 mm. The fabrics are quite varied, both oxidized and reduced types are represented: OC 1, OC 2, OC 3, RC 1, RC 3, and RC 5.

PO 5 (Pl. 27/5). Outsplayed, straight rim, rectangular lip. The mouth opening ranges between 120 and 300 mm. The fabrics comprise mainly oxidized types: OC 2, OC 3, and OC 4.

PO 6 (Pl. 27/6). Everted and thickened rim, triangular lip with rounded corners, lid-seating. The mouth opening ranges between 120 and 220 mm. The fabrics are varied, with both oxidized and reduced types represented: OC 2, OC 3, and RC 3.

PO 7 (Pl. 27/7). Outsplayed thinned rim, rounded lip. The mouth opening ranges between 150 and 200 mm. Fabric type: OC 2.

PO 8 (Pl. 27/8). Outsplayed thickened rim with rounded lip and lid-seating. Mouth opening: 220 mm. Fabric type: RC 4. Only one example can be ascribed to this type.

2) Casseroles (CA)

The category consists of relatively short vessels with carinated body, displaying either an angular or a curved carination, usually in conjunction with a flat base. In terms of the shape and function of these vessels, a direct analogy can be drawn up with the Italian vessel-type known as *caccabus* (see above). According to other authors the origin of this form should be sought in the Late Iron Age Celtic milieu.⁴⁴² The variants with angular carination (see below, type CA 5) have usually horizontal smooth or reeded rims,⁴⁴³ and are usually designated with the term *caccabus* in publications

⁴⁴⁰ Ciaușescu/Mustață 2009, 250.

⁴⁴¹ Meyer-Freuler 2013, 368.

⁴⁴² See Cupșa 2009, 20.

⁴⁴³ Filip 2008, 57.

even in cases when it is obvious that they belonged to the category of tableware, displaying fine fabrics and colour-coating.⁴⁴⁴ They can be found in high numbers within the Italian assemblages of the 1st and 2nd century AD.⁴⁴⁵ This form is rare within the local cookware assemblages, however it is quite common within the category of stamped tableware from Dacia Porolissensis.⁴⁴⁶ With regard to the variants with curved carination, the rims of the respective vessels display a very similar morphology with certain types of pots, which occasionally hinders the identification of smaller fragments. As to the size of the vessels, the variation of the mouth openings is quite high, ranging between 170 and 270 mm.

Catalogue of forms:

CA 1 (Pl. 28/1). Everted rim, rounded lip with a horizontal groove. Mouth opening ranging between 130 and 150 mm. Fabric types: OC 1 ad RC 3. Only two examples can be ascribed to this type.

CA 2 (Pl. 28/2). Outsplayed thinned rim with external reeding and rounded lip. Mouth opening: 200 mm, fabric type: OC 4. Only one example can be ascribed to this type.

CA 3 (Pl. 28/3). Outsplayed and thickened rim with an angular lip. The mouth opening ranges between 170 and 220 mm. Both oxidized and reduced fabrics are represented: OC 1, OC 2, RC 2, and RC 3.

CA 4. (Pl. 28/4). Outcurved rim with rounded lip and horizontal groove. The mouth opening ranges between 200 and 300 mm. Fabric types: OC and OC 2.

CA 5 (Pl. 28/5). Short horizontal rim with triangular lip, angular carinated body. The mouth opening ranges between 250 and 270 mm. Fabric types: OC 2 and RC 2. . Only two examples can be ascribed to this type.

3) Pans (PA)

This category consists of short vessels with wide mouth openings, flat base and slightly everted walls. According to Graham Webster's definition, the height of these containers is situated between one-third and one-seventh of the mouth opening's diameter.⁴⁴⁷ In terms of the general shape, the present class displays marked similarities with the category of tableware discussed above under the heading: 'platters (PL)', comprising recipients made from fine and semifine fabrics and covered with colour-coating specific for fineware. Conversely, the vessels discussed in this section are made from coarse fabrics and do not display signs of colour-coating, but instead exhibit traces of intense secondary burning, mainly in the form of consistent layers of soot. Based on the morphological analogies, a direct link can be established with the category known in the publications as: 'Pompeian-red ware'.⁴⁴⁸ The only notable, albeit significant difference is the lack of the emblematic intense red slip applied in thick layers, which inspired the name of the Italian vessel type, which was occasionally exported to the Danubian provinces. Accordingly, the category discussed here can be regarded as the 'local' variant of the so-called 'Pompeian-red ware'. This Italian vessel type also known as 'Internal red-slip cookware (IRSC)' was produced starting with the 3rd century BC

⁴⁴⁴ Vámos 2002, 15–16.

⁴⁴⁵ Olcese 2003, 10–28, Fig. 8.

⁴⁴⁶ Filip 2008, 57–58.

⁴⁴⁷ Webster 1976, 18.

⁴⁴⁸ Rusu-Bolindeț 2007, 343.

in the region of Campania in Central Italy, the production continuing until the 2nd century AD in numerous centres throughout Italy and Gaul.⁴⁴⁹ These vessels were consistently exported to the provinces starting from the early period of production,⁴⁵⁰ this fact probably accounting for the emergence of a 'provincial' production of the type.

The present assemblage is entirely made up of fragments. All the same, due to the morphological characteristics of the type, i.e. the shortness of the walls, the complete section of the vessels can be reconstructed in the majority of cases, accounting for the most straightforward classification of the present study. With regard to the distribution of forms, the degree of diversity is quite high (see below), however in absolute numbers the overwhelming majority of vessels (around 83%) belong to just three types, all displaying inturned or almost vertical rims (Figure 25). In terms of the dimensions, around 95% of cases have mouth openings in excess of 200 mm (Figure 37). The variety of forms is even higher in the case of the assemblage published in the monograph, as shown by the three plates illustrating exclusively forms belonging to this class, although no differentiation was made with regard to the fabrics (Figure 26).⁴⁵¹

Catalogue of forms:

PA 1. (Pl. 29/1–2). Everted rim not individualised from the body, rounded lip with interior vertical groove. The mouth opening ranges between 190 and 300 mm. Fabrics: OC 2, OC 4, and RC 3.

PA 2 (Pl. 29/3). Outsplayed and thickened rim, angular lip. The base of the rim is marked by an external groove. The mouth opening ranges between 230 and 260 mm. Fabric: OC 2.

PA 3 (Pl. 29/4). Vertical or slightly everted rim, with both internal and external horizontal grooves, and rounded lip. The mouth opening ranges between 190 and 400 mm. Fabric types: the overwhelming majority of cases consists of RC 3, other types includes OC 2, RC 2, and RC 4.

PA 4 (Pl. 29/5). Inturned rim with internal groove and rounded lip. The present type is the only one with footring on the base. The mouth opening ranges between 250 and 400 mm. Fabric types: RC 2 and RC 3.

PA 5 (Pl. 29/6–7). Slightly everted or vertical rim, reeded and thickened lip. The mouth opening ranges between 290 and 330 mm. The fabrics belong to the type RC 3.

PA 6 (Pl. 29/8) Inturned, thinned rim, rounded lip. This type has close analogies in the category of tableware. It is by far the most common form in the present assemblage. The mouth opening ranges between 170 and 370 mm. The fabrics are quite varied, the most common types being: RC 1, RC 2, RC 3, OC 2, and OC 3.

PA 7 (Pl. 29/9). Outcurved rim with subangular lip. The mouth opening ranges between 350 and 450 mm. Fabric types: OC 2. Only two examples can be ascribed to this type.

⁴⁴⁹ Peacock 1977b, 147–148; Peña 1990, 647–648; Tyers 1996, 156–159.

⁴⁵⁰ Peña 1990, 647.

⁴⁵¹ Chirilă et al. 1972, Pl. XIX, XX, and XXI.

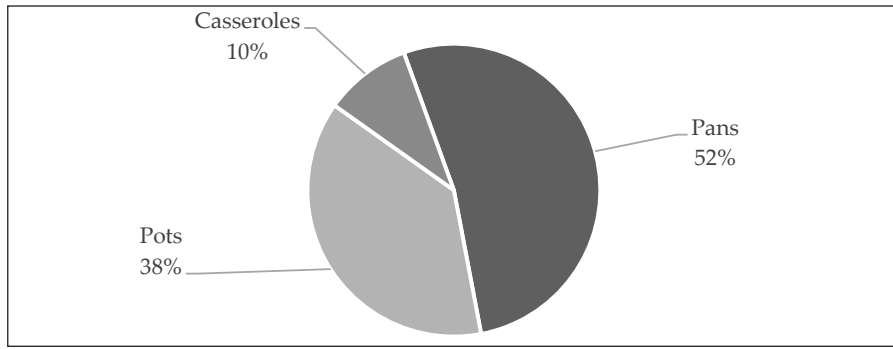

Figure 24. The distribution of vessel classes within the category of cookware.

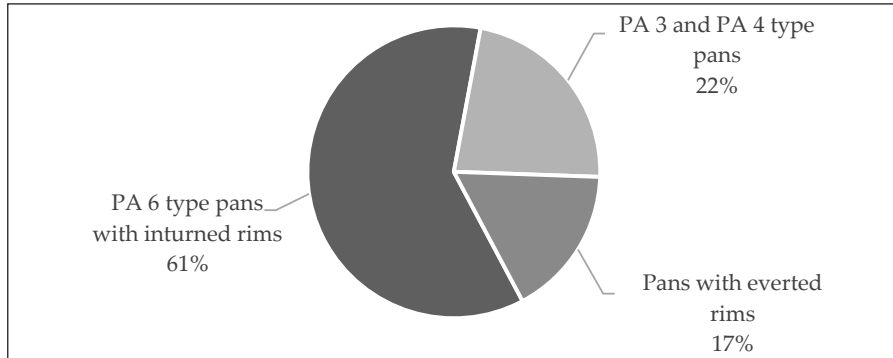

Figure 25. The distribution of forms within the class of pans (PA).

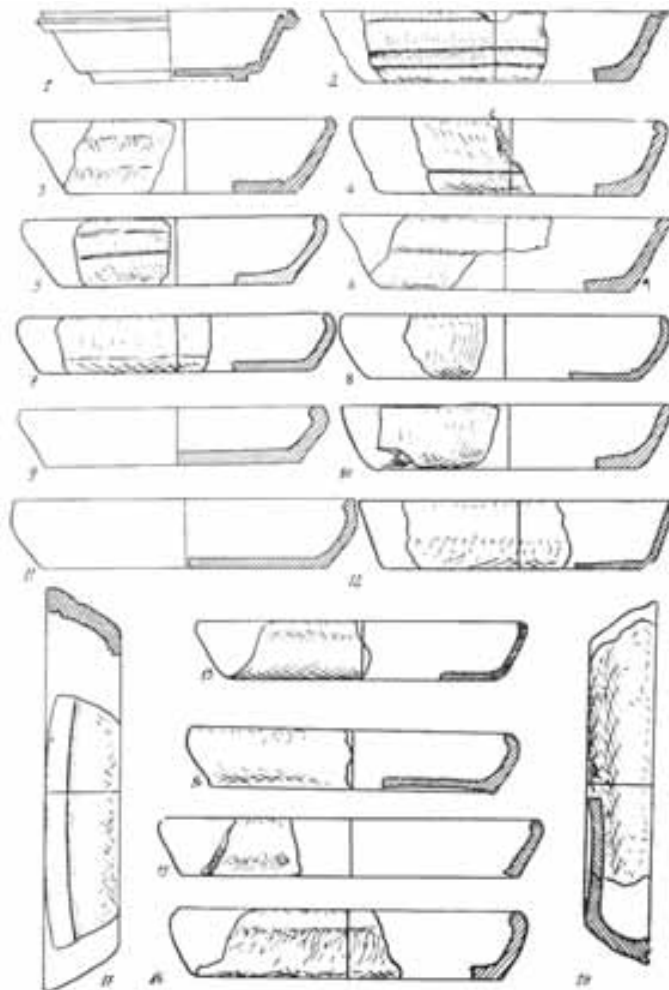

Figure 26. Pans published in the 1972 monograph.

4.2.4. *Non-food-related pottery containers (including lamps)*

The category discussed throughout this section comprises certain types of pottery finds which are traditionally associated in publications with pottery vessel assemblages. The reasons for this connection are manifold, and at least in part can be explained by the vessel-like appearance of these objects. Some of them, such as the 'washing basins' and even lamps technically qualify as vessels in the true sense of the word i.e. hollow containers primarily used to hold liquids, while others, such as the *turibula* can only be regarded as vessels on account of their appearance and production technique (wheel throwing). Even though lamp studies have evolved over the last two decades into a somewhat distinct field of research labelled as 'lychnology', dealing with multiple aspects of artificial lighting prior to the invention of electric illumination,⁴⁵² the connection between the research methods and programmes concerning the pottery vessels and lamps still seems to be quite firm. Furthermore, given the similar technological requirements involved in the production of these pottery goods (wheel throwing, moulding, colour-coating, etc.), and similar marketing trends, and distribution, an integrated approach seems to be justified.⁴⁵³ What is more, in most cases the categories under scrutiny here must have been produced in pottery workshops that primarily manufactured containers employed for the transport, storage, processing, and serving of foods. Conversely, the 'containers' discussed below were admittedly used in various other pursuits, such as ritual activities, possible storage, personal hygiene, and lighting.

4.2.4.1. *Washing basins*

The fairly large hemispherical bowls with free-standing or attached loop handles (either smooth or torsioned), usually made from semifine fabrics and without colour-coating are usually identified as 'washing basins' (*Waschbecken*), and conventionally linked with bathing activities.⁴⁵⁴ The identification is based mainly on the fact that they clearly imitate bronze vessels known to have been produced for this purpose. The bronze prototypes ('hemispherical basins with stand and fixed handles'), included by Eggers in his types 99–100 were produced between 25/35 AD and 115/130 AD.⁴⁵⁵ The pottery variant of this type of basin occurs on a number of military sites across the European sectors of the Limes, on the Danube, the Rhine and in Britain.⁴⁵⁶ There is some degree of morphological variation however, in some cases the handles are attached to the vessel body, while in others they are projecting away from the body in similar fashion with their bronze prototypes.⁴⁵⁷ Some of the occurrences can be linked with the presence of either the main body or detachments of the Legio XI Claudia especially at Vindonissa as well as the Middle and Lower Danube.⁴⁵⁸ Outside this area, the vessel also emerged at the legionary base from Nijmegen and a series of mainly legionary sites from Britain beginning with the period of Hadrian's rule.⁴⁵⁹ According to our current knowledge, a relation between the fort at Buciumi and the abovementioned legion cannot be asserted, the presence of the basin can only be explained as a typical

⁴⁵² See the activity of the International Lychnological Association (<http://www.lychnology.org>).

⁴⁵³ The inclusive take on Roman pottery studies is endorsed and promoted by the official association of Roman pottery specialists, the *Rei Cretariae Romanae Fautores* (<http://www.fautores.org/>).

⁴⁵⁴ Meyer-Freuler 2013, 365.

⁴⁵⁵ Mustață 2017, 131.

⁴⁵⁶ Meyer-Freuler 2013, 368, Fig. 315.

⁴⁵⁷ Meyer-Freuler 2013, 365, Fig. 314/1.

⁴⁵⁸ The list of sites includes: Rottweil (Kastell I), Mirebau, Brigetio (Pannonia) and Drajna de Sus (Lower Moesia), see Meyer-Freuler 2013, 365–366, Fig. 314; 374, Fig. 318.

⁴⁵⁹ Haalebos 1992, 369–370, Abb. 2 (Nijmegen); Swan 2004, 269, Fig. 3/45 (York); 266, Fig. 2/36; 264, Fig. 1/9 (Holt); 266, Fig. 2/36 (Caerleon); 277, Fig. 7/100 (London).

component of ‘legionary ware’ (i.e. ‘military pottery’ used by both the legionaries and auxiliaries) and may be indeed related with the pronounced propensity for hygiene of the Roman army.

Apart from the present vessel (see below), no instances of this category were hitherto reported as such from Roman Dacia, although a survey of previously processed assemblages does reveal the existence of a handful of cases. Accordingly, three such basins were discovered in the auxiliary fort at Samum/Căşieu,⁴⁶⁰ and one in the civilian settlement of the auxiliary fort at Cristeşti.⁴⁶¹ All have spiral grooved handles. As mentioned before, the current assemblage yielded only one such fragmentary hemispherical basin with two loop handles adjoined to the container’s body (Pl. 30/1).⁴⁶² The fabric is semifine, with hardly any temper incorporated (moderate amounts of mica and occasional calcite), light brick-red in colour, unslipped. Diameter: 270 mm, height (partially preserved) 93 mm, wall thickness: 9 mm. The bronze vessel finds from Buciumi also include a washing basin fragment, belonging however to the somewhat later type Eggers 79/83 (‘Steep-walled basins with attachments shaped like grapevine leaves’)⁴⁶³ dated between 160/180 AD and 230/250 AD.⁴⁶⁴ Furthermore two bronze strigils were discovered in barracks no. 5,⁴⁶⁵ as well as a number of finds usually included in the vague and ambiguous category of ‘medical/toilet/domestic objects’,⁴⁶⁶ such as cosmetic palettes, tweezers, spatulas, and based on the catalogue description comprised by the monograph, glass perfume bottles.⁴⁶⁷ At a hypothetical level all of these objects can be related to the general phenomenon of personal hygiene.

The washing basins are not the only category of pottery vessels known to have been used for the maintenance of personal hygiene. The case of the bronze bowls with cylindrical handles or *Griffschale* was already mentioned above (see Chapter 4.1). Pottery versions of these bowls have been reported from a number of sites across Roman Dacia, the largest number coming from Apulum,⁴⁶⁸ although only the two fragments discovered in the Trajanic fort at Draşna de Sus can be clearly linked with a military use.⁴⁶⁹ Given the prevalence of washing basins in the military environment, it might be possible that these basins were actually used as replacements for the *Griffschale* for hand-washing. The small number of pottery washing basins reported from military sites in Roman Dacia, can be ascribed to the fact that these vessels can easily evade the excavators and the authors of the finds reports, as shown by the two abovementioned examples, especially if the handles are missing.

4.2.4.2. Incense burners (*turibula*)

The incense burners or *turibula* are most often associated with incense offerings (incense being scattered on the hot embers held inside the vessels), although there has been some speculation concerning their exact role in rituals, some arguing that they might have been used for libation as well, drawing on the lack soot on some vessels and the occasional presence of holes on the bases.⁴⁷⁰ In

⁴⁶⁰ Cupşa 2009, 460, Nr. 351, 386, 398, Fig. 91, S11a/9.

⁴⁶¹ Information kindly provided by the researcher of the site dr. Nicoleta Man.

⁴⁶² Petruş 2016, 646–647, fig. 4/16.

⁴⁶³ Mustaţa 2017, 134, no. 65, Pl. XXXV/65, LXXXII/65a–b.

⁴⁶⁴ Mustaţa 2017, 134.

⁴⁶⁵ Chirilă et al. 1972, 81, nos. 1–2, Pl. CXII/1–2.

⁴⁶⁶ Gui 2011, 120–121, 124.

⁴⁶⁷ Chirilă et al. 1972, 109–114, Pl. CXXXII–CXXXIV.

⁴⁶⁸ Rusu 1997, 340–344, Taf. I–III. A fragment discovered in the fort at Buciumi in building no. 4 (Chirilă et al. 1972, 52, Pl. XXXVII/4; Rusu 1997, 341, Taf. II/3) was also considered to be a *Griffschale* handle, although its unusual segmentary structure makes this assumption very unlikely.

⁴⁶⁹ See Ştefan 1948, 132, Fig. 14/1–2; Rusu 1997, 341, Taf II/4–5.

⁴⁷⁰ Fiedler/Höpken 2004, 511–512.

addition to this, numerous other potential uses were put forward, both ritual and worldly,⁴⁷¹ ultimately however there is a general agreement concerning the cultic use of this category of vessels. Unfortunately, no detailed observations of base holes and sooting patterns can be made in the case of the finds from Buciumi, given the fragmentary nature of the material. Besides the typical shape and decoration, a further characteristic is the use of very coarse fabrics, essential for withstanding the thermic shock to which these vessels were normally subjected to.

The monograph published in 1972 contains a number of twelve incense burners, all but two coming from the barracks of the fort, with eight from barracks no. 5.⁴⁷² The hitherto unpublished material comprises only ten new incense burners, with seven coming from barracks no. 1 (Figure 27). All in all, a number of twenty-two finds were identified from an incomplete overview of the material from the barracks at Buciumi, the total number being probably much higher. The widespread presence of *turibula* on virtually all types of Roman sites and structures⁴⁷³ can be understood as a reflection of the fact that ritual activities involving incense and possibly myrrh offerings were a fundamental part of everyday life, and as such were not confined to specially designated spaces, being especially common in living quarters, belonging to the basic household kit, the *penus*, according to some literary sources.⁴⁷⁴ This, possibly in conjunction with certain practical uses, such as that of insect repellent, or heater, accounts for their widespread presence.

The extremely fragmentary condition of the unpublished lot hinders any attempts at typological classification (Pl. 30/2–5). Nevertheless, a rich array of forms is suggested by the material published in the monograph. The range of fabrics is quite wide, although the oxidized types make up the clear majority. The commonest fabrics are: OC 5 and OC 2, while the somewhat surprising presence of a semifine fabric type (OS 1) must also be noted. The mouth opening of the vessels ranges between 130 and 260 mm.

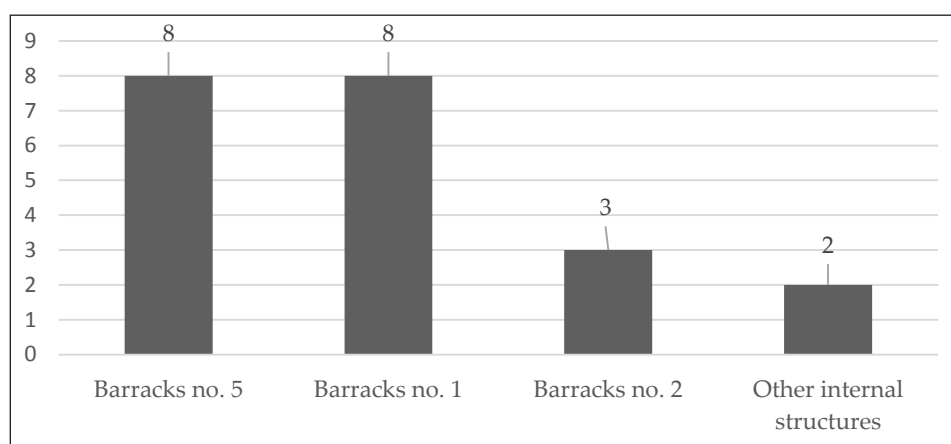

Figure 27. The spatial distribution of incense burners (*turibula*).

4.2.4.3. *Miniature vessels*

The problem of miniature vessels is to this day fraught by ambiguity. The main question is what can and what cannot be included into this category and what primary functionality – if any – can be associated with this group. In the first comprehensive study regarding the miniature votive offerings in the north-western provinces of the Roman Empire, Philip Kiernan defined the category of miniature objects as either the direct reduction of their life-size prototypes, or as

⁴⁷¹ See Harsányi 2006.

⁴⁷² Chirilă et al. 1972, 50–51, Pl. XXV–XXVI.

⁴⁷³ See Mihăilescu-Bîrliba 1996, 97–98.

⁴⁷⁴ See Harsányi 2006, 65–71.

non-functional objects, or objects with considerably modified functionality compared to their prototypes.⁴⁷⁵ The author concluded that in reality the number of pottery vessels which fit this definition is much smaller than that which is usually reported by archaeologist, indeed pots which are very small are not necessarily miniature vessels.⁴⁷⁶ We also have to bear in mind that it was quite natural for potters to produce vessels using the same guidelines, thus a reduction in size did not necessarily mean a change in form.⁴⁷⁷ The exact function of the miniature vessels is far from being straightforward, however, owing to the fact that the vast majority of these objects can be linked to ritual contexts, related mainly to temples and shrines, their cultic function seems to be the most likely possibility. The main question involves their interpretation as either votive offerings or the possibility that they might have played a different role in the ritual process, as containers for oils, perfumes and incense during the anointing of cult statues, or even as vessels for ritual drinking.⁴⁷⁸ Admitting their primary use as votive offerings, it is still very difficult to decide whether the vessels themselves were offered or rather their content. A further scenario draws on the possibility that the potters themselves could have offered some of their specially made products in a votive act.

The assessment of miniature vessels is further hampered by the 'inference' of the equally elusive category of amphora stoppers, small ovoid (*eiförmige Gefässe*) or spindle-shaped (*birnenförmigen Gefässe*, or *amphoriskoi*) containers which often closely resemble miniature vessels. In recent years the very nature of these containers came under question, partly due to the analysis of a large assemblage of 'amphora stoppers' from Vindobona by Rita Chinelli, who found that we are in fact dealing with small multifunctional vessels. The author's argument was based on the fact that the finds from Pannonia are likely to have been locally made, moreover, they never seem to be associated with amphorae within the archaeological contexts.⁴⁷⁹ Among the material hitherto published from Buciumi, a single case of spindle-shaped miniature vessel can be identified.⁴⁸⁰ At any rate, a total of thirteen possible miniature vessels can be assumed in the respective material, consisting mostly of small ovoid cups with one handle.⁴⁸¹ In addition to this, one further unpublished miniature recipient can be added to the list (see below).

The spatial distribution of the finds can be described as follows: nine pieces from barracks no. 5, one piece each in barracks nos. 1, 2, and 4, one piece was discovered in the tower of the main gate (*porta praetoria*), while the exact place of discovery of one vessel is unknown.

71. Miniature beaker. Pl. 30/6.

Probably of local production, unknown dating.

Unpublished. Dm. 40 mm, H. 51 mm, Th. 5 mm. Fabric type: OS 1, without colour-coating, uneven firing. The beaker has one handle, its body is ribbed, the ridges concentrating in the upper part of the vessel and fading away in its lower part.

Barracks no. 1; X. 15–16 m, Y. 3 m, d. 0.3 m.

No inv. no., Mus. Zalău.

⁴⁷⁵ Kiernan 2009, 165

⁴⁷⁶ Kiernan 2009, 167.

⁴⁷⁷ Kiernan 2009, 168.

⁴⁷⁸ Kiernan 2009, 168.

⁴⁷⁹ Chinelli 2005, 156–159. The possible functions of these vessels suggested by the author are: *unguentaria*, candlestick, ceramic building elements for vaulted structures (formwork), dice cup, etc.

⁴⁸⁰ Chirilă et al. 1972, 43, no. 3.

⁴⁸¹ Chirilă et al. 1972, 43, no. 3; 44, nos. 28–38, 40.

4.2.4.4. *The lamps*

The lamps discovered in the fort were hitherto published in numerous studies, including a comprehensive specialist report,⁴⁸² a monograph comprising the lamps from a number of military sites in Dacia Porolissensis,⁴⁸³ as well as a study focusing on the question of illumination in the barracks of legionary and auxiliary soldiers in Roman Dacia.⁴⁸⁴ All in all, around sixty-one lamps were discovered in the fort's various structures, as expected the overwhelming majority (forty-seven) coming from the barracks.⁴⁸⁵ In addition to the hitherto published lamps, further two pieces will be added here. The extensive discussion regarding the classification of forms, their chronology, and the functional and technological aspects (covered in the next section) will not be reiterated, given that sufficient attention was already provided to these topics in the aforementioned studies. Suffice to say that the variety of forms is quite pronounced (Figure 28), the assemblage consisting of both mould-made and wheelthrown types. Notwithstanding the difficulties in assessing the exact place of production of the lamps, based on the general features of the artefacts, and the characteristics of the fabrics, it can be asserted with a high level of certainty that the bulk of the material is of local origin, while the incidence of potential imports is relatively low. The most conspicuous case is a small fragment belonging to the Loeschcke I-C type discovered in barracks no. 4, with a stamped inscription on the shoulder (Pl. 31/10).⁴⁸⁶ The meaning of the fragmentary inscription, consisting of the sequence: [---] RADIC[---], was until recently unknown, indeed similar shoulder inscriptions, containing usually either the producer's name or some sort of aphoristic message, being quite rare.⁴⁸⁷ A closer analysis of the fragment revealed that it probably belongs to a well-defined group of Loeschcke I-C lamps most likely produced in Poetovio/Ptuj (Upper Pannonia) displaying the stamped inscription: *pauperis • cena • pane vinu • radic*, i.e. 'the poor man's meal (consists of), bread, wine and roots (i.e. root vegetables)'.⁴⁸⁸ Given the magnitude of the production in Poetovio/Ptuj, which was one of the major lamp-producing centres of the Empire during the 2nd–3rd centuries AD,⁴⁸⁹ in addition to the fact that the only cases of such lamps were hitherto discovered in the respective site, it is very likely that we are dealing with an imported piece in this case.

With regard to the chronology of the finds, in the overwhelming majority of cases no conclusive data is available for assessments of this nature. In addition to the unreliability of the chronology ascribed to the construction/habitation phases (see the discussion in the previous sections), the inherent chronological value of the 'classical' lamp typologies have only a very limited scope with regard to finds from Dacia. As was asserted before, this is due mainly to the interval of the province's occupation, and the particularities of the local production which does not fit into the general global classifications.⁴⁹⁰ This applies, on slightly different levels, to all of the three large categories of ceramic oil lamps, i.e. the 1) 'picture lamps', 2) the 'Firmalampen' and the 3) 'wheel-made circular lamps' (Figure 30). The lighting devices included in the category of 'picture lamps' (Bildlampen), comprised of Siegfried Loeschcke's types I–VIII, in the context of Italian production (but also some of the 1st century provincial manufactures, see below) exhibit the best chronological indicators.⁴⁹¹ However, their exports, with only a few exceptions, are limited to the 1st century

⁴⁸² Gudea/Cosma 2003; for a revised German edition see Gudea/Cosma 2008.

⁴⁸³ Roman 2006.

⁴⁸⁴ Petruț et al. 2014.

⁴⁸⁵ Petruț et al. 2014, 81, Fig. 10 (the paper features forty-six lamps, two unpublished pieces have emerged since).

⁴⁸⁶ Gudea/Cosma 2003, 23, nr. 2.

⁴⁸⁷ Bailey 1988, 106–108.

⁴⁸⁸ CIL III, 14114, 13a, 13b; Istenič 1999, 137. I wish to thank my colleague Levente Daczó for his help in elucidating the text and the origin of the stamped inscription.

⁴⁸⁹ Istenič 1999, *passim*.

⁴⁹⁰ Petruț et al. 2014, 76–77.

⁴⁹¹ Eckardt 2002a, 22.

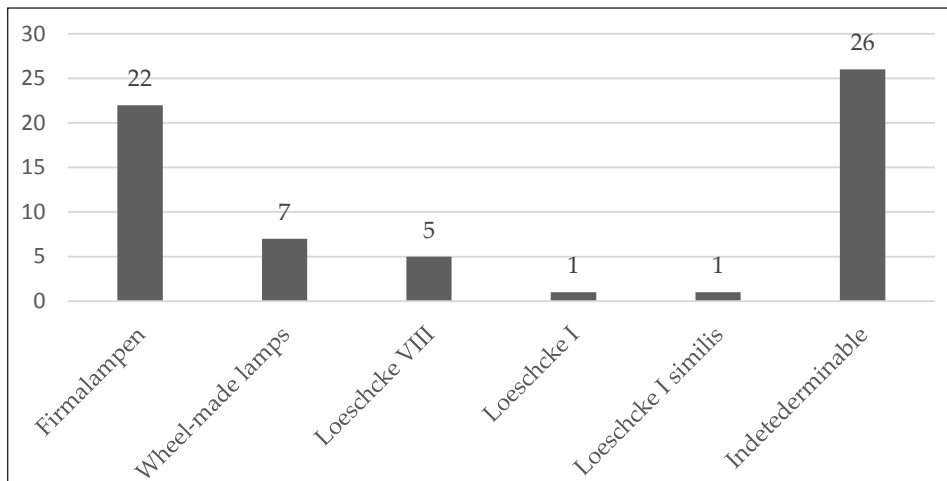

Figure 28. The distribution of lamp types.

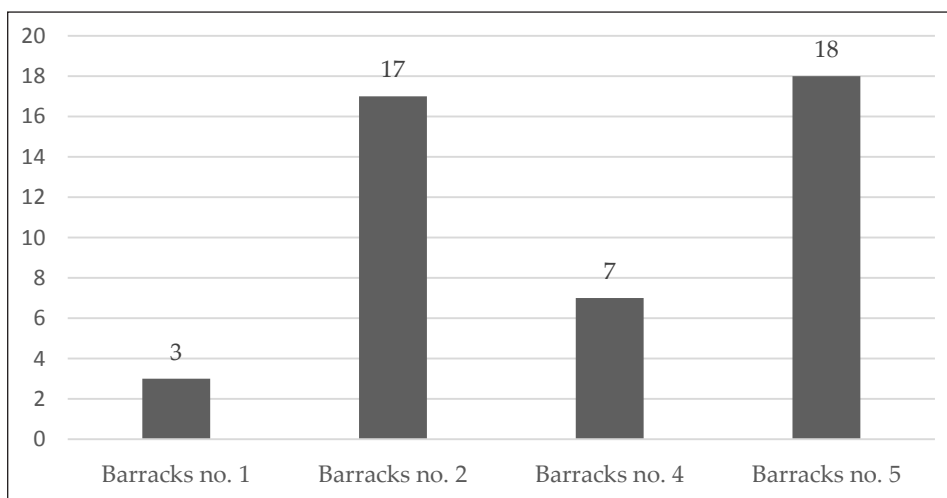

Figure 29. The spatial distribution of pottery lamps.

AD, in the period prior to Dacia's integration into the Empire.⁴⁹² The examples of 'picture lamps', present in relatively high numbers in Dacia and consisting mostly of various provincial variants loosely based on Loeschcke type VIII lamps⁴⁹³ (especially the 'pear-shaped' undecorated lamps, see Figure 30/5), display a time span that covers the entire Roman rule in the territory of Dacia.⁴⁹⁴ The later variants of the volute lamps referred to as Loeschcke type I-B and especially I-C, have a production period which ends in the early Trajanic period in Italy.⁴⁹⁵ Nevertheless, their production seems to continue throughout the 2nd century AD in certain provinces, e.g. Pannonia.⁴⁹⁶

The same is valid for the Firmalampen category. The production of the early variants designated as Loeschcke type IX lamps was halted at the beginning of the 2nd century AD.⁴⁹⁷ Consequently, their presence is very rare in Dacia, although the few examples of this type can be regarded as chronological indicators for the respective period. The later variant (Loeschcke type X), on the other hand, has a time span that encompasses the entire 2nd century AD, with the production continuing throughout much of the 3rd century,⁴⁹⁸ thus its chronological significance in the context of

⁴⁹² Bailey 1980, 314–376.

⁴⁹³ It is highly debatable whether these types can be linked at all to the Loeschcke VIII prototype.

⁴⁹⁴ Roman 2006, 40.

⁴⁹⁵ Bailey 1980, 152.

⁴⁹⁶ Iványi 1935, 29.

⁴⁹⁷ Roman 2006, 41–42.

⁴⁹⁸ Harris 1980, 143–144.

Roman Dacia is quite limited. The case of the so-called ‘wheel-made circular lamps’ is somewhat similar. The emergence of this category is usually ascribed to a change in the manufacture technology (wheel throwing rather than moulding), prompted in part by modifications in lamp usage, which consisted mainly in a shift from vegetal oil fuels to animal fat (tallow) in the 2nd century AD. This type is relatively widespread in Roman Dacia. Contrary to earlier assumptions, its production and propagation started in the 2nd century AD and lasted up to the 4th century,⁴⁹⁹ thus proving less informative with regard to the chronological evolution of the lighting devices from Roman Dacia. A further difficulty in this line of study resides in the fact that the vast majority of lamps in Dacia appear to be local products, partly in accordance with William V. Harris’ concept regarding the preponderance of local production and distribution of ceramic oil lamps,⁵⁰⁰ even though there is still no evidence for the existence of a system of organized branch workshops in this province or elsewhere. For this reason, the provincial variants which make up the bulk of the oil lamps in Dacia are quite distant from the Italian prototypes, but also from other provincial variants, e.g. the lamps coming from Pannonia and Germany in terms of chronology, production technique, decoration, and indeed overall quality.⁵⁰¹

The distribution of the lamps across the barracks (Figure 29) reflects the structure of the soldiers’ quarters, the two double barracks (nos. 2 and 5) yielding more than twice as many lamps as the two simple barracks (nos. 1 and 4).

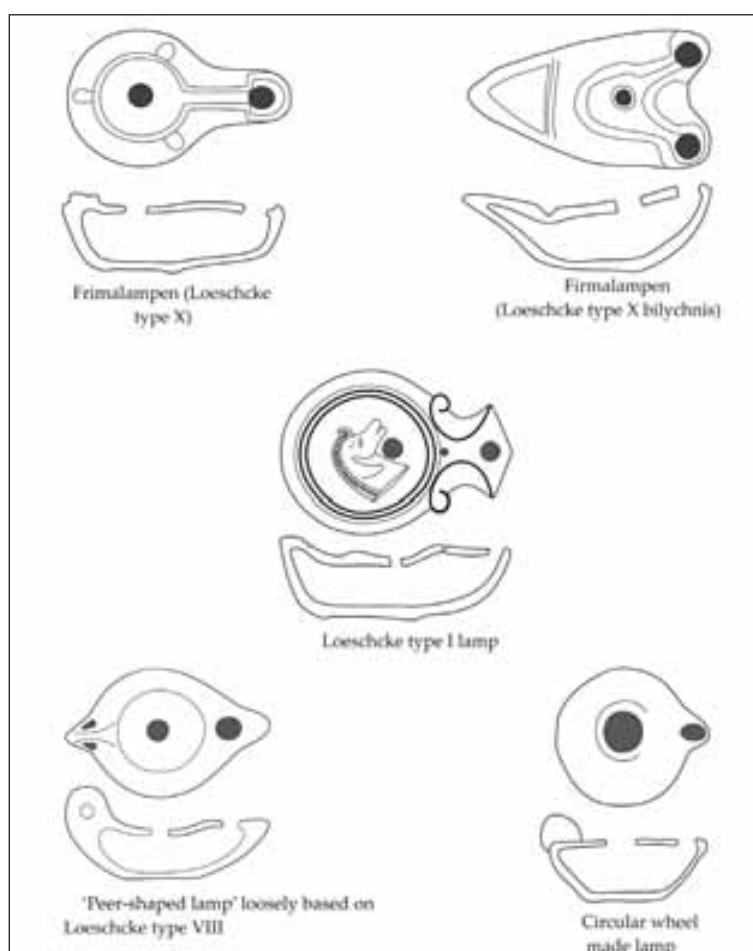

Figure 30. The classification of the most common pottery lamp forms from Roman Dacia.

⁴⁹⁹ Eckardt 2002a, 33; Negru 1996, 76–77; Roman 2000, 122–123; Roman 2006, 26, 30.

⁵⁰⁰ Harris 1980, 134–137.

⁵⁰¹ Bailey 1988.

The finds catalogue of the hitherto unpublished pieces:

72. Wheel-made lamp. Type Roman II A. Pl. 32/1.

Provenance: local product.

Barracks no. 1; X. 3 m; Y. 7 m, d. 0.8 m.

Unpublished; Dm. 50 mm, H. 24 mm, Th. 3 mm, L. 50 mm; fabrics: OF 2, without colour-coating. Circular form, without a nozzle. The filling hole is 13 mm wide.

Inv. no. 319/1973; Mus. Zalău.

73. Wheel-made lamp. Type Roman II A. Pl. 32/2.

Provenance: local product.

Barracks no. 1; X. 3 m, Y. 7 m, d. 0.8 m.

Unpublished. Dm. 57 mm, H. 25 mm, Th. 5 mm. L. 62 mm; fabrics: OC 6, without colour-coating. Circular form with a very short nozzle, thus displaying some affinities with the type Loeschcke VIII. The filling hole is 15 mm wide, allowing the use of tallow as fuel.

Inv. no. 319/1973; Mus. Zalău.

4.2.5. *The assemblage published in the 1972 monograph*⁵⁰²

In assessing the pottery supply (i.e. local production and imports) to the fort at Buciumi, a short incursion into the assemblage published in the 1972 monograph is called for, despite the fact that in addition to barracks' finds it contains the material from other structures as well (*principia*, *praetorium*, etc.). Moreover, the morphological evidence provided by the published material was cited throughout the earlier sections, insofar as it was deemed instructive with regard to the question of the present vessel types. Before putting forward any critical comment with regard to the aforementioned report, it must be underlined that the publication at hand was among the first enterprises of its kind that attempted to construct a valid dataset for the ceramic finds of a military site in Dacia, in a period when the informational value of archaeological finds devoid of textual and iconographic evidence – especially pottery – was still mostly overlooked. A further reason for the necessity of this short review has to do with the nature of the material published nearly half a century ago. Indeed the report contains quite a high number of intact or fully restored vessels, which might prove to be instructive given the extremely fragmentary nature of the present material. The major limitation in this case concerns the character of the illustration which in some cases seems to be less reliable, occasionally producing forms that are not consistent with the features of Roman provincial pottery.

Regardless of this, the pottery assemblage, as are the other finds, is richly illustrated, surpassing the standards of the time in the archaeological literature concerning Roman Dacia. Given the goals set forth in this section, the review will focus on the pottery vessels that comply with the features of local production. Before turning to the composition of the assemblage and its classification, it must be underlined that the amount of finds belonging to certain category or form, and its proportion within the assemblage does not denote any quantitative relevance. Moreover, the respective classification was based exclusively on morphological criteria (i.e. the general shape of the vessels) without taking into account the fabrics of the vessels.

The classification of the local wheel-made pottery vessels comprises the following categories: pots ('oale/Töpfe'), bowls ('străchini/Schüssel'), lids ('capace/Deckel'), 'fruit bowls' ('fructiere/Fruchtschalen', i.e. *turibula*), cups ('pahare/Becher'), jugs ('căni/Kannen'), flagons ('ulcioare/

⁵⁰² The information included in this section is taken from the catalogue description of the local wheel-made pottery assemblage in the monograph: Chirilă et al. 1972, 42–52. References to the exact page numbers and plates are given in brackets in the text.

Krüge'), *dolia* ('chiupuri/Krausengefässe'), *mortaria*, amphorae ('amfore/Amphoren'), and saucepans ('patere/Pateren').

With regard to the pots ('oale/Töpfe'), as expected, the variety of forms is quite considerable, furthermore a group of intact and relatively small-sized examples can be ascribed to the category of jars (see above, Figure 22). Moreover, a group of globular and ovoid beakers, some with handles akin to the Italian thin-walled beakers (see above), can also be identified within this category (Pl. V). Apart from these two groups, the rest of the fragments belonging to this category displays the same features as the pots from the present assemblage (p. 43–45, Pl. VI).

The category termed 'bowls' ('străchini/Schüssel') is in fact an umbrella-term for several forms (p. 45–49). According to the authors of the report, the category consists of three main forms: 1) deep bowls with footring base (i.e. 'bowls' according to our current classification), 2) deep bowls with flat base (i.e. 'casseroles'), and 3) shallow bowls, which are further divided into variants with flat base (i.e. platters and pans, depending on the fabrics), and footring base (i.e. dishes). The authors underline the scarceness of fragments belonging to the category of 'shallow bowls with footring base' (dishes) and the large numbers of variants with flat base (p. 49), although without the grouping of the material according to the fabrics, we have no sense of the proportion between the instances of tableware (i.e. platters) and cookware (i.e. pans). The incense burners are included under the heading 'fruit bowls' with no awareness of their actual functionality (p. 50–51). The case of the jugs and that of the flagons is especially instructive due to the relatively large number of intact or restored vessels which provide a useful informational base for the fragments in the present assemblage (see above, Figures 20, 21). No details are given with regard to the *dolia* and *mortaria* apart from their very low numbers (p. 52). The case of the so-called *paterae* consists of several handle fragments belonging to pottery imitations of bronze saucepans (Figure 35).⁵⁰³

A further category worth mentioning even though it is not represented in the current assemblage is that of the handmade pottery, which according to the authors consists of pots, platters/pans ('shallow bowls with flat base') and one possible instance of 'Dacian mug'. The respective material was interpreted as evidence for the presence of native Dacians in the fort (p. 53–54), an assertion already put forward a few years earlier in a separate paper.⁵⁰⁴ This was of course in line with the official historical narrative of the time (see Chapter 1.4). With regard to this possibility, Mircea Negru in a comprehensive study of handmade vessels from Roman Dacia has shown that a considerable part of these assemblages consist of vessels made according to a Celtic tradition, indicating the activities of Norico-Pannonian settlers, while in other cases we are dealing with the handmade variants of typically Roman forms, such as the pans.⁵⁰⁵ All the same, the proportion of the handmade vessels probably was not particularly high, their absence from the present assemblage being quite telling in this regard. Their presence could be explained by possible deficiencies in the pottery supply most likely in the early stages of the fort's occupation, as well as by certain particular culinary necessities.⁵⁰⁶

Finally, the case of the so-called face pots must be mentioned. All in all, a number of eight fragments belonging to this interesting category must be underlined (p. 42; Figure 31). Although their exact functionality is hitherto unknown, it is quite certain that they were employed in cultic activities together with *turibula*, terracotta statuettes and possibly other objects.⁵⁰⁷ They were directly associated with the cult of Liber Pater, the mask having apotropaic functions.⁵⁰⁸ Given that most

⁵⁰³ Petruț 2016, 644.

⁵⁰⁴ Gudea 1970, 299, 306.

⁵⁰⁵ Negru 2003, 9, 34.

⁵⁰⁶ Negru 2003, 38.

⁵⁰⁷ Braithwaite 2007, 388, 395.

⁵⁰⁸ Braithwaite 2007, 395.

of the vessels from this category are pots, it is likely that they were used for the preparation and mixing of ceremonial drinks.⁵⁰⁹

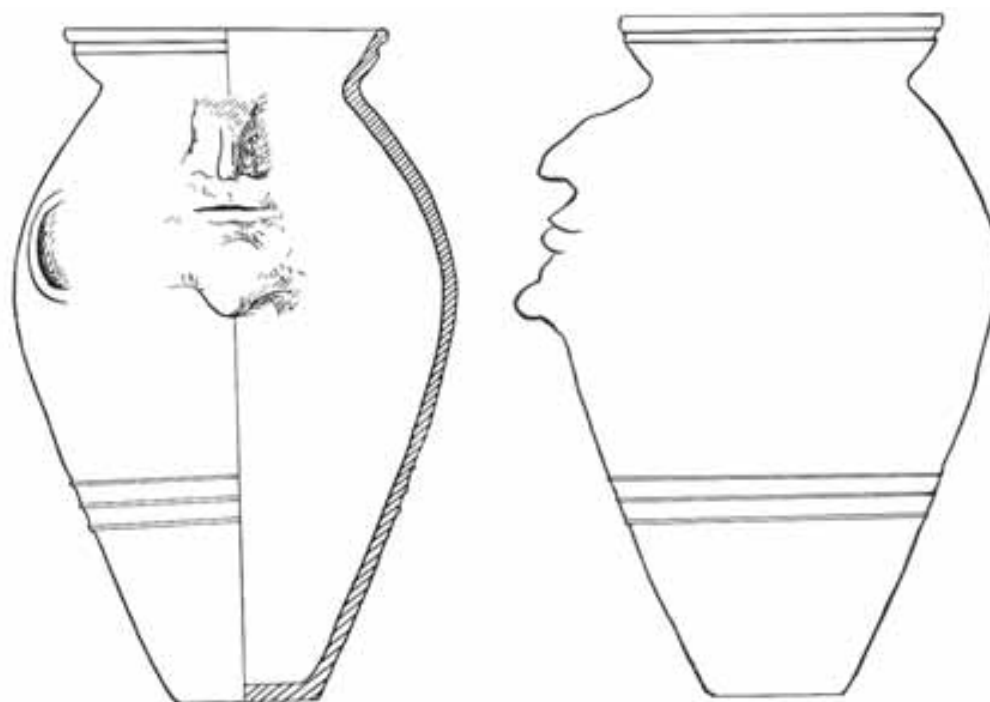

Figure 31. A reconstructed face pot published in the 1972 monograph.

4.3. Functional aspects. Evidence concerning the use of pottery vessels and lamps

The object of the current section is to bring together the technological and morphological evidence which can be translated into data regarding the manner in which the vessels grouped into the classes and forms described above were employed by the members of the fort's garrison throughout the occupation of the base. It is hoped that by pairing this dataset with the physical observations of use (wear and tear, soot accumulation on the vessels' surface, etc.) recorded on each individual fragment and quantified at various levels, will help in obtaining some insight into the role of the different vessels in the culinary process. In addition to this, the roles of the pottery lamps in the illumination of the barracks and practical implications of this process (type of fuel used, the amount and quality of light obtained, the functional possibilities of certain types of lamps) will also be explored briefly. The discussion will include all technological categories which were addressed throughout the previous sections.

4.3.1. *Technological aspects related to functionality*

Given the complex nature of the subject, its investigation relies on a constantly growing number of aspects in tune with the expansion of the prospects and reach of archaeometric methods. The approach is based on the integrated analysis of morphological and technological aspects, involving mainly the quality and the type of fabrics employed.⁵¹⁰ The detailed aspects of functionality can be investigated at the level of an individual vessel or sherd insofar as the respective finds provide enough data in this regard, and even more so if the contextual information is instructive in terms of the vessels' use. Unfortunately, in the majority of cases no useful contextual information is

⁵⁰⁹ Braithwaite 2007, 395.

⁵¹⁰ Orton et al. 1993, 217–222.

available. All the same, the quantification of the data obtained through the individual observations can lead to the understanding of the functional implications inherent to certain classes and forms of vessels.⁵¹¹

Notwithstanding the obvious limits of conferring valid quantitative significance to the proportion between the categories which make up the assemblage (see above), the breakdown of the three main functional groups displays a somewhat balanced situation (Figure 32), although we have no way of knowing to what extent this reflects a realistic situation. Even though its quantification is problematic, the extremely low incidence of drinking vessels, amounting for less than 5% of the entire assemblage is perhaps the most conspicuous element of this analysis. The respective figure results from adding certain forms such as Drag. 33 terra sigillata imports which were possibly not manufactured primarily as drinking vessels, or potentially had a double functionality, i.e. that of dipping bowl (*acetabulum*) and drinking cup. It is difficult to assume that this does not reflect at least in part the realities of pottery vessel usage in the fort, although, as mentioned in the previous sections, the assemblage published in the monograph does contain some globular and ovoid beakers (see above). Accordingly, we can assume a possible preference for glass drinking vessels, which unfortunately cannot be properly documented, as a specialist report covering the glass finds has not been published so far. At any rate, the 130 glass vessel fragments included in the monograph catalogue comprise a certain number of drinking vessels based on the published photographs.⁵¹²

The close link between the quality of the fabrics and the direct functionality of the vessels can be examined at many levels. First of all, we can assume a connection between the type of firing and the vessel's function, as reduced fabrics were only employed on a larger scale in the case of the cookware, while their share within the tableware and utilitarian ware falls well short of the oxidized fabrics (Figure 7). Still, while the type of firing and implicitly the colour of the finished vessel was mostly a matter of the potter's choice and of the market's demand, the composition and quality of the fabrics was decisive in terms of their actual use. This is perfectly illustrated by the distribution of the fabric types across the three main functional groups (see Chapter 4.2). Accordingly, coarse fabrics make up the overwhelming majority of the cookware, semifine fabrics dominate clearly within the category of utilitarian ware, while fine fabrics make up the majority within the tableware, with semifine fabrics falling just short of half (Figure 9). In the case of the cookware, the use of coarse fabrics, most often heavily tempered with quartz grains was essential in order for the vessels to endure the constant thermic shock they were subjected to. This requirement was clearly not imposed on the production of utilitarian ware. Furthermore, given the fact that vessels from this category were not typically used for serving foods and drinks (with the exception of some flagon types) there was no immediate need which justified the use of fine fabrics, which presumably took more effort and time to prepare.

All in all, the category of utilitarian ware is quite uniform from a technological point of view, the overwhelming majority of jugs and flagons being made from semifine fabrics. The most notable exception is the case of vessels belonging to type JU 5 termed 'water jugs', produced from coarse oxidized fabrics. The ethnographic evidence shows that such large jugs were used for the storage of drinking water, the increased permeability of the coarse porous fabrics stimulating the evaporation process, which in turn resulted in maintaining the vessel's contents at a cool temperature.⁵¹³ In the case of the tableware, the incidence of semifine fabrics is only slightly lower than that of the fine fabrics, a situation potentially determined by the difference in price and the exigency of the buyers.

⁵¹¹ Tyers 1996, 42.

⁵¹² Chirilă et al. 1972, 109–114, Pl. CXXXIV.

⁵¹³ Orton et al. 1993, 220–221.

4.3.2. *The physical traces of use*

A further method of investigating the functional aspects of pottery vessels and assemblages consists of systematic and quantified observations regarding the physical traces of use visible on the vessels' surface. The principle is that certain types of surface wear and tear are directly linked with the usual usage of the vessels, and are caused by constant and sometimes prolonged employment in the culinary process of adjacent activities. In the case of the cookware the traces usually consist of soot accumulation, alteration in the colour of the fabrics, and fissure in the vessels' walls, caused by the exposure to thermic shock.⁵¹⁴ The presence or absence of secondary burning traces is usually viewed as an indicator for the function of the respective vessels. There are however several limitations to this method, probably the most significant one being the limited applicability in the case of fragmentary material, as the soot resulted from culinary activities is not evenly distributed on the vessels' surface, instead being concentrated to certain areas depending on the cooking method employed.⁵¹⁵ Furthermore, it must be underlined that these aspects are not regularly noted in the publications concerning Roman Dacia, thus hindering the integration of this data at a larger scale.

As mentioned above, the pattern of sooting is regarded as being potentially indicative as to the cooking method employed. Therefore, in the case of vessels suspended or placed on various types of supports (tripod, hearth, or grill) above the heat source, the soot accumulation is regularly formed on the lower part of the vessel. Conversely, in situations when the vessels are placed directly in the hot ash or among the embers, the sooting is concentrated in the lower half of the vessel excepting the base, as well as on the outer surface of the rims, in the case of vessels with everted, outplayed or outcurved rims.⁵¹⁶ In the case of the present assemblage, only a part of the fragments display signs of secondary burning, a significant amount of fragments belonging to the category of cookware being devoid of sooting traces. This situation can be best explained by the extremely fragmentary character of the assemblage, composed overwhelmingly of rim fragments. This effectively means that only the fragments of vessels used in a specific way have preserved the traces of soot accumulation. In the case of the pots, these traces can be seen on the shoulders and the upper part of the vessels' rims, including the inner surface. Moreover, there is also the possibility that some vessels or fragments were affected by secondary burning after they were discarded, a scenario which is difficult to document and quantify in the case of such fragmentary material.

Other possible signs of wear and tear include scratches and abrasion on the inner surface of open vessels produced by the use of various utensils such as knives and spoons, or simply caused by the prolonged use of the vessels. The study of wear and tear on Roman period pottery vessels, not surprisingly has hitherto concentrated on finewares, especially terra sigillata, given the special interest exhibited generally in this category in addition to the fact that due to the good quality of the fabrics and of the slip, the traces of use are more meaningful and usually can be easily documented.⁵¹⁷ The studies that have so far addressed this issue, were usually based on three types of evidence: 1) cut marks (scratches) on the inner surface of the vessel produced by the use of knives, 2) abrasion of the slip on the underside of the base, most often on the footring, indicating prolonged and possibly 'intense' use (such as in the case of *mortaria*), and 3) abrasion of the slip on the interior of the vessel, indicating stirring and possibly grinding.⁵¹⁸ The latter is usually visible in the form of small chippings of the slip grouped together in a ring-shaped pattern on the interior of the base.

Not surprisingly, with regard to the present assemblage such traces are only visible in the case

⁵¹⁴ Orton et al. 1993, 222–223.

⁵¹⁵ Cool 2006, 39–42.

⁵¹⁶ Orton et al. 1993, 222.

⁵¹⁷ Peña 2007, 59–60.

⁵¹⁸ Peña 2007, 59–60.

of the terra sigillata. It should be underlined from the outset that several fragments exhibit a ring-shaped abrasion pattern (nos. 29, 52, 55,), similar to the sort described above, however a closer look makes it clear that we are not dealing with instances of wear and tear, instead the traces are the result of the staking process inside the kiln prior to firing.⁵¹⁹ This kind of surface damage could be related to the practice of sprinkling the foot-rings of the vessels stacked together in the kiln with sand in order to ensure that they will not stick together during firing, which can occasionally cause a ring-shaped imprint on the vessel-floor.⁵²⁰ A further possibility is that the feature is in fact the imprint of a stacking ring used to ensure that the vessels remain separated inside the kiln.⁵²¹ At any rate, the feature present on at least three fragments (nos. 29, 52, 55,) from the current assemblage was clearly produced when the slip was still soft, and therefore it can only be linked to the process of production. The situation is quite different in the case of base fragments displaying abrasion of the slip on the footrings (nos. 29, 26, 52, 54, 55,). In most cases the abrasion is limited to the edge of the footrings, i.e. the part which was constantly in contact with the surface of the table or any other working surface. Given the good quality and durability of Gaulish and Rhenish sigillata slip, it is possible that intense stirring and grinding typical for the use of *mortaria* has contributed to the respective surface damage which otherwise would not have ensued. Cut marks and chippings of the surface on the basal interior of the vessels can be also observed in a few cases (nos. 29, 53, 55).

The evidence from Roman Britain indicates that the incidence of vessels with heavy traces of wear and tear as well as signs of repair increases in periods marked by shortages in the supply of terra sigillata.⁵²² As already mentioned above, some signs of wear and tear indicate alternative or secondary uses of some vessels.⁵²³ Such a situation can be implied in the case of a Drag. 35 dipping-bowl (no. 34) with barbotine decoration on its rim. A close observation of the fragment reveals that the barbotine stripes are affected by abrasion, suggesting that the vessel may have been used upside down, perhaps as a lid. Unfortunately, there is no possibility to further verify this hypothesis.

4.3.3. Aspects regarding the culinary practices and evidence of conviviality

The current section is dedicated to the analysis of evidence concerning the processes of food preparation and consumption within the community of soldiers from Buciumi. Once again it has to be underlined that the low resolution of the contextual data hinders any attempt of isolating certain groups of vessels within the assemblage which might have been used together possibly as sets, instead the discussion will be based on the totality of the material. As mentioned in the previous sections, the cookware commonly used in the Danubian provinces throughout the 2nd and 3rd centuries AD typically consisted of three main classes of vessels: pots (*olla*), casseroles (*caccabus*), and pans (*patina*, *patella*).⁵²⁴ Notwithstanding the chronological fluctuations of their use (see above), for the most part these types of vessels were used in a complementary fashion.⁵²⁵ It is suggested here that this complementarity can be illustrated in the case of the present assemblage through the comparison of the data referring to the dimensions of the respective vessels. It is for this reason that the fragments of pots and pans were quantified according to their mouth opening, the threshold being set at 200 mm. Although the value is clearly artificial, it potentially marks the transition between vessels used for individual and communal purposes.

⁵¹⁹ Petruț 2014, 18.

⁵²⁰ Biddulph 2008, 93.

⁵²¹ Martin 2010, 17.

⁵²² Peña 2007, 59–60.

⁵²³ Peña 2007, 61–209.

⁵²⁴ Meylan-Krause 2002, 122.

⁵²⁵ Meylan-Krause 2002, 122–124.

A further point of discussion refers to the exact functionality of the cooking vessels, which can to a certain extent be deduced from the same dataset. With regard to the pots, the quantification shows that the proportion of the vessels with mouth openings equal or higher than 200 mm amounts to merely 15%, while the smaller vessels make up the bulk of the material with 85% (Figure 36). The result is somewhat surprising and might indicate that the employment of these vessels might have been somewhat less varied than previously thought. The case of the pans shows exactly the opposite situation, with only 5% of the vessels having mouth openings below 200 mm (Figure 37). This is somewhat unsurprising considering the primary function ascribed to this type. As mentioned above, there is a direct connection between the provincial types of pans and the so-called ‘Pompeian-red ware’, most likely used for baking bread (*panis focacius*) by immersing the lidded vessel into the hot ash of a hearth.⁵²⁶ It has to be pointed out however that up to this point there is no physical evidence in the present assemblage for the type of lids usually associated with ‘Pompeian-red ware’.⁵²⁷ Needless to say, the identification of lids is even more difficult in the case of a fragmentary material such as the one at hand. Indeed it cannot be excluded that some of the shallow vessels considered here were in fact used as lids, or that regular pot lids with knobs were employed.

Until assemblages are published containing both the vessels and their corresponding (and fitting) lids, we will lack any certainty in this respect, however it is also possible that this versatile and quite possibly multifunctional form was in fact used with more than one type of lid. The range of forms is quite wide, the majority having clear correspondents in the repertoire of forms ascribed to Pompeian-red ware.⁵²⁸ If indeed their primary function was linked to bread baking, this would provide an explanation for the high proportion of the type within the assemblage. The bread baking technique known as ‘*sub testu*’ in the ancient literary record,⁵²⁹ which made use of the hot ashes of the hearth and either a metal or pottery pan⁵³⁰ or the bell-shaped cover (*clibanus*) had clear benefits over the classical use of bread oven, which first of all needed to be constructed. This technique effectively meant that the soldiers were provided with a portable oven which required only the setting up of a hearth. Still there is no reason to exclude the multifunctional use of pottery pans, which in addition to making bread could have been employed for cooking meats or vegetables. At any rate, their high number suggests a quite intense usage.

With regard to the pots, given their small dimensions, it is unrealistic to presume that they could be used for preparing more than one portion at a time. Most often pots are linked with the preparing of various type of porridge (*puls*),⁵³¹ a staple food in both the civilian and the military environment, which could effectively be used as a quicker and more convenient substitute for bread.⁵³² It is reasonable thus to presume that pots were used for cooking individual portions of *puls*. The low number of casseroles in turn could be linked with their lower degree of versatility, and possibly the fact that their use required the existence of some sort of a suspension system, most likely tripods or portable hearths, which could have acted as a disincentive in this case.

With respect to the serving vessels, a similar survey is aimed at defining the role of the so-called ‘communal vessels’ within the category of tableware. This category is especially significant considering that we are dealing with the highly cohesive communities of *contubernales*,

⁵²⁶ There is no clear consensus hitherto in the literature regarding the functionality of these vessels (Peña 1990, 648, footnote 4) however their primary use as ‘bread pans’ seems the most likely scenario, see Junkelmann 1997, 129–130.

⁵²⁷ Peacock 1977b, 156–157; Tyers 1996, 157–159.

⁵²⁸ Peacock 1977b, 157, Fig. 3.

⁵²⁹ Junkelmann 1997, 130; Cool 2006, 52.

⁵³⁰ For circular bronze bread pans see Junkelmann 1997, 130, Abb. 68.

⁵³¹ Meylan-Krause 2002, 122.

⁵³² Junkelmann 1997, 128.

who, according to our knowledge, prepared their food together. The social significance of communal food consumption translated into instances of conviviality cannot be overvalued as it was one of the key cohesion factors for a wide range of communities in the cultural context of the Roman Empire.⁵³³ Studies, based especially on various types of terra sigillata have pinpointed the phenomenon whereby the overall dimensions and especially the mouth opening of the dishes and bowls tend to increase starting with the late-2nd century in unison with the general drop in the production of sigillata throughout the Empire.⁵³⁴ This tendency was linked with the changes occurring in the practice of conviviality illustrated by the consumption of meals from communal vessels.⁵³⁵

Accordingly, the vessels belonging to the category of tableware were quantified based on the diameters of their mouth openings. This time the threshold was set at 300 mm. In the case of vessels with a mouth opening equal or higher than this value, it is reasonable to assume communal, rather than an individual use.⁵³⁶ The results show that 36% of the analysed vessels fit in this category (Figure 33). With over a third of the assemblage the percentage is considerable as it is, but it is sufficient only to slightly lower the threshold and the percentage rises exponentially, suggesting that the real proportion of communal vessels might have been even higher. Furthermore, over half (58%) of the 'communal vessels' belong to the type BO 2 (so-called 'Bowls with central cordon') inspired from the Drag. 44 type (Figure 34). This data can be interpreted as an illustration of the conviviality within the groups of *contubernales*, although the assemblage does not allow further assertions in this regard.

What is also clear is that some of the vessels were used for individual dining by their owners, as shown by the dimensions of some of these containers and more manifestly by a DI 1 type dish with an ownership mark *graffito* incised on its side, revealing the name of the vessel's proprietor and the *centuria* to which he belonged: '*Zanax, milis 7(centuria) Genia[elis]*'.⁵³⁷ At this stage it is quite impossible to effectively assess the ownership of the vessels within the barracks *contubernia* in general, however it is safe to assume that these issues were not necessarily very strictly regulated.

Further evidence of conviviality can be deduced from the presence of so-called saucepans ('*Kasserollen*'). These bowl-like vessels with horizontal handles, made from both bronze and silver, were used primarily for wine-mixing,⁵³⁸ and based mainly on iconographic evidence, it is often claimed that they were part of the marching equipment of soldiers on campaign.⁵³⁹ A recent analysis of the metal vessels in Dacia Porolissensis has revealed four fragments of bronze saucepans discovered in barracks nos. 2, 4, and 5.⁵⁴⁰ Additionally, three fragments of pottery saucepans were also identified in the fort's barracks, the pottery variants of these metal vessels being quite common in Dacia.⁵⁴¹ All in all, the seven instances suggesting the use of wine-mixing bowls (Figure 35) can potentially increase our insight into the question of wine consumption and conviviality in the fort at Buciumi.

The data provided by the utilitarian ware in terms of their role in the culinary and consumption process is somewhat limited in comparison with the other two functional groups discussed above. First of all the presence of the hemispherical and conical 'strainers' has to be noted. As

⁵³³ Dunbabin 2003, 11–18.

⁵³⁴ Hawthorne 1998, 164–167, Fig. 2–3.

⁵³⁵ Hawthorne 1998, 165–168; for the general context see Dunbabin 2003, *passim*.

⁵³⁶ The threshold was set in Hawthorne's (1998, 167, fig. 3) analysis between 200 and 250 mm. For reasons of precaution, in the current study it was raised to 300 mm.

⁵³⁷ Dana/Petruț 2015.

⁵³⁸ Petrovsky 1993, 85–88; Mustață 2017, 85–86 ('casserole').

⁵³⁹ Junkelmann 1997, 88–89, Abb. 37.

⁵⁴⁰ Mustață 2017, 184–185.

⁵⁴¹ Chirilă et al. 1972, 52, Pl. XXXVII/2, 3, 5; Petruț 2016, 644–646, Fig. 3/1, 2.

already mentioned, previous studies have effectively shown the link between these vessels and cheese-making, demonstrating that in fact we are dealing with cheese-presses. A further point worth making concerns the conspicuously low number of *mortaria*, all the more so as the affinity for the use of *mortaria* is directly linked with the military. On a different note, the large number of *dolia* combined with the considerable dimensions exhibited by some of the examples from the assemblage (mouth opening of 450 mm) suggest that large quantities of liquids (water, wine, olive oil, etc.) were stored in the barracks at Buciumi. Furthermore, it is quite likely that water was usually stored in large jugs made from coarse fabrics in order to ensure that it maintained a low temperature (see above).

4.3.4. *Military pottery?*

The question of military pottery, or ‘legionary ware’⁵⁴² (see Chapters 1.3 and 1.4) as it is commonly known in the literature, essentially revolves around two questions. First of all, are there any verifiable and consistent (therefore recurring) differences between the pottery assemblages of the civilian urban environment and those of the military bases? Secondly: are there any palpable differences in terms of pottery production and usage between the various military units making up the Roman army, or at least between the legions and the auxiliary units? The answer to both questions is surely affirmative, even though a superficial review will usually conclude that Roman pottery was the same in all corners and environments of Dacia. The reason for this lies usually in the subtle nature of these variations which in most cases are only reflected in the proportion of types and categories comprised by these assemblages and not always in the presence of certain culturally specific vessels produced and used exclusively or mainly by the army or particular units, although this argument can be made in some cases (see below). In this regard the overwhelming prevalence of bowls inspired from the Drag. 44 types noted in the recently investigated barrack blocks of the legionary fortress at Potaissa/Turda is relevant,⁵⁴³ as is the massive dominance of bowls among the tableware (around 70%) in comparison with dishes noted in the case of the auxiliary forts at Bologa and Samum/Căseiu.⁵⁴⁴ The same tendencies can be highlighted in the case of the present assemblage (see Chapter 4.2.1.1). Moreover, the presence of washing basins (see Chapter 4.2.4.1) and the so-called ‘handled pots’ described as pots with two or three handles made from coarse oxidized fabrics without traces of soot and used for the transport and storage of water, most likely corresponding to the containers termed ‘water jugs’ in the present assemblage (type JU 5),⁵⁴⁵ might also be indicative of military ware. The second question, i.e. the issue of the potential variations between assemblages belonging to different units is even more elusive. This phenomenon hypothetically reflects the particularities of the troops’ cultural background and therefore can be traced back to the region from where the soldiers were recruited.⁵⁴⁶ Indeed, ‘Roman pottery’ is far from being a monolithic and uniform reality, consisting not only of Italian and more widely Mediterranean pottery, but also incorporating to varying degrees local Late Iron Age traditions reflected by the presence of particular production techniques and vessel forms. In the case of the aforementioned assemblage from Potaissa/Turda a clear connection was found with the products of the workshops operating around Troesmis in Lower Moesia, which was the previous base of Legio V Macedonica.⁵⁴⁷

⁵⁴² The terms ‘military pottery’ or ‘military ware’ are more adequate for reasons highlighted in Chapter 1.3 as well as in the current section.

⁵⁴³ See Nemeti et al. 2017, 99. (L. Nedelea)

⁵⁴⁴ See Cupşa 2009, 778.

⁵⁴⁵ See Cupşa 2009, 32–33.

⁵⁴⁶ See the discussion at the end of Chapter 1.3.

⁵⁴⁷ See Nemeti et al. 2017, 84–85. (L. Nedelea)

With regard to the possible differences between legionary and auxiliary units in terms of the potter assemblages associated with the two categories of military sites, probably the most obvious aspect involves the question of imported pottery containers. The longstanding view of Roman provincial archaeology whereby the legions enjoyed differential treatment in terms of the supply of certain commodities, especially amphora-borne products (olive oil, wine and *garum*) usually seems to be corroborated by the archaeological record (see Chapter 4.2.2.2). Unfortunately, this hypothesis cannot be properly tested against the realities of the material culture of Roman Dacia, since very few amphorae have been hitherto published from Apulum and Potaissa, the two long-term legionary bases of the province. Similar tendencies can be suspected with regard to so-called 'luxury commodities' such as terra sigillata, although the reasons for this are probably more complex than the differences between the pay grades of legionaries and that of auxiliaries.

'Legionary ware' is typically discussed in terms of production and industry, however the phenomenon should also be viewed in terms of functionality,⁵⁴⁸ as it reflects both certain tastes of the military consumers, but also various sets of needs generated by a particular lifestyle within these military communities. In the case of the present material, both the affinity of the tableware for terra sigillata forms (see above), and the massive preponderance of red slip ware (Figure 8) amounting to roughly 85% of the tableware, is in concordance with the general patterns of military consumption and indeed, 'legionary ware'.⁵⁴⁹ Furthermore, the presence of tableware decorated in the so-called cut-glass technique, with close analogies at military production sites in Britain and elsewhere (particularly at Holt, in the vicinity of Deva/Chester in North Wales) (see above, the description of type BO 1), of pottery imitations of wine-mixing bowls (the so-called saucepans), of pottery washing basins, and of the so-called face-pots, is highly indicative of military pottery, or legionary ware, reflecting phenomena such as military conviviality, personal care and hygiene, and possible cultic activities characteristic to the military.⁵⁵⁰ Furthermore, the lid-seated, necked type pots/jars with prominent shoulders affiliated to a Mediterranean tradition, are also commonly linked with a military-style consumption, hence the term *Militärkochtöpfe*.⁵⁵¹

With regard to the assemblage discovered in the legionary fortress at Apulum/Alba Iulia, and published in 2006 by Mihaela Ciaușescu, the author asserted that the first ceramic industry at the aforementioned site was established by craftsmen closely associated with Legio XIII Gemina, who arrived with the troops, and consequently whose products display a clear affinity with the pottery produced in Pannonia at that time, the province where the unit served prior to its departure for the Dacian Wars.⁵⁵² The establishment of the pottery industry by civilian manufacturers, who accompanied the troops during their relocations, and the subsequent dissemination of their style of production to the urban civilian environment, as seems to be the case of Dacia, indicates that the military supply could not rely on the local, pre-Roman production. It would be thus interesting to consider, whether this situation can offer an explanation for the general characteristics of what is normally viewed as Roman pottery in the province of Dacia, i.e. the conspicuously high degree of similarity with what elsewhere may be considered 'legionary ware', often defined with the label 'Romanized'⁵⁵³ in provincial contexts, and the very low incidence of material reflecting any local pre-Roman pottery tradition.⁵⁵⁴ The situation seems to be contrary in character to the pottery of

⁵⁴⁸ Petruț 2016, 648.

⁵⁴⁹ Ciaușescu 2006, 144; Petruț 2016.

⁵⁵⁰ See the discussion in Petruț 2016.

⁵⁵¹ Meyer-Freuler 2013, 368.

⁵⁵² Ciaușescu 2006, 146–147.

⁵⁵³ Ciaușescu/Mustață 2009, 250, 254.

⁵⁵⁴ Negru 2003, *passim*.

most western provinces, such as Britain, dominated by large local industries rooted in the Late Iron Age ceramic tradition.⁵⁵⁵ At any rate, the role of the military in introducing a new ceramic tradition in the fledgling province of Dacia must have been quite significant, and the matter needs to be awarded more attention in the future if we are to unravel the genesis and evolution of pottery manufacture in Roman Dacia.

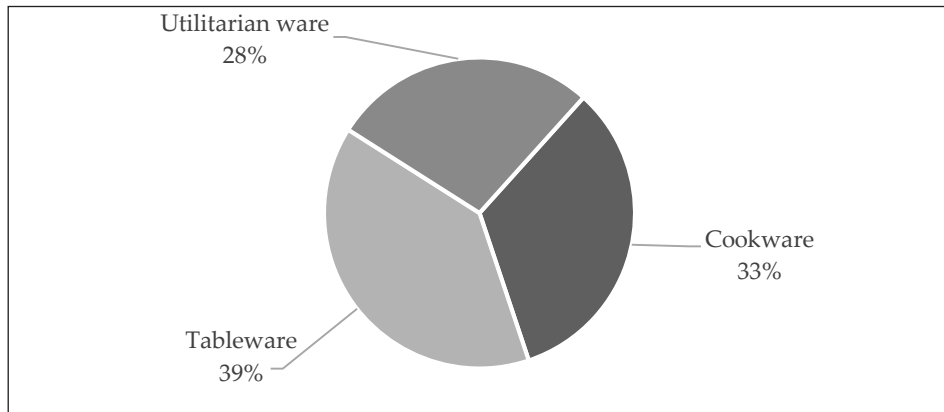

Figure 32. The distribution of functional categories within the assemblage.

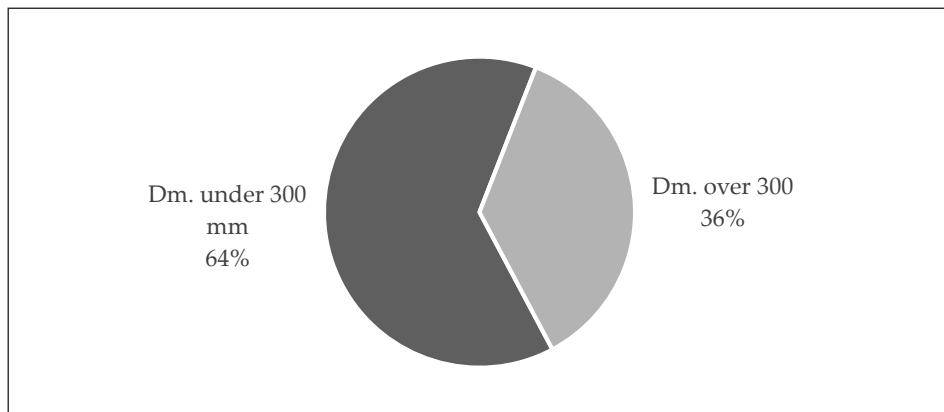

Figure 33. The distribution of 'communal vessels' (mouth Dm. over 300 mm) within the category of tableware.

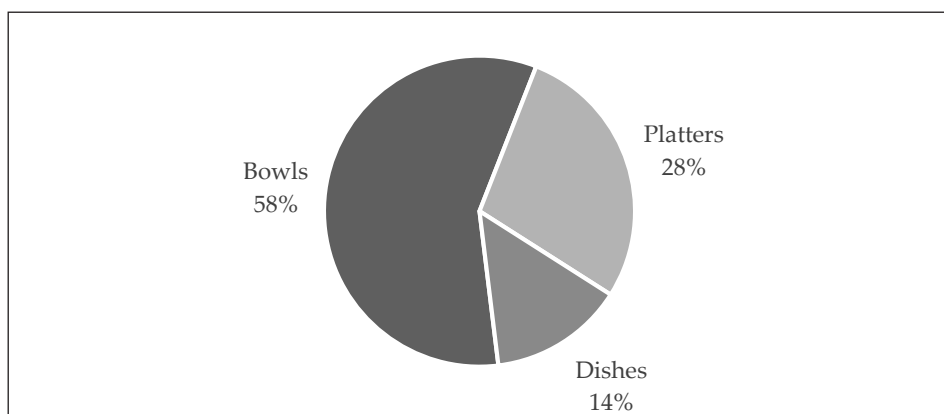

Figure 34. The composition of 'communal vessels'.

⁵⁵⁵ Tyers 1996, passim.



Figure 35. Pottery 'saucepan' handles published in the 1972 monograph.

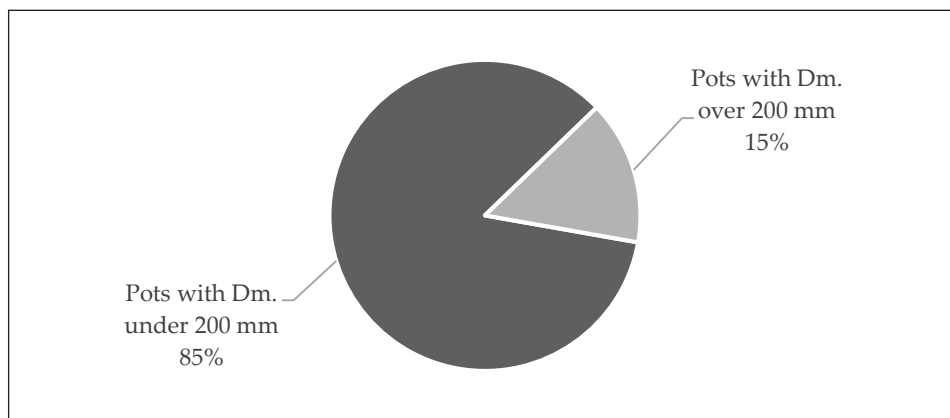

Figure 36. The distribution of pots according to the mouth openings (Dm.).

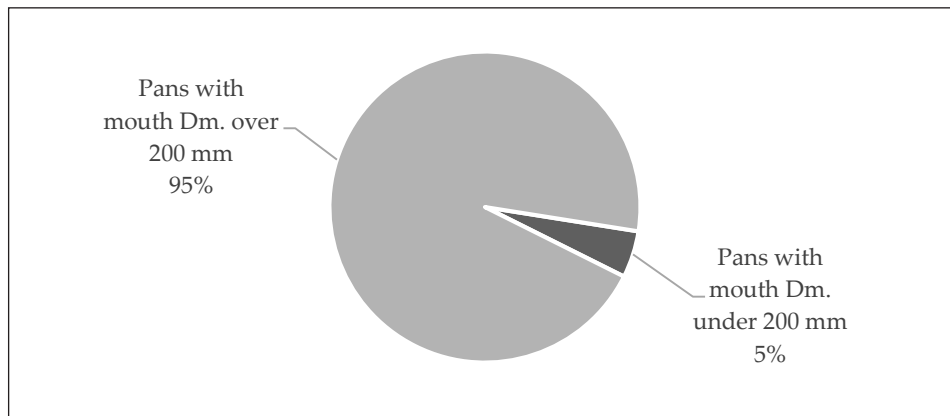

Figure 37. The distribution of pans according to the mouth openings (Dm.).

4.3.5. The evidence related to the use of artificial lighting

According to our current knowledge of soldiers' barracks in the aforementioned period, the architectural features of these structures did not provide access to a suitable amount of natural light; therefore, the need to attend to this shortcoming by means of artificial lighting would seem evident. In fact, the barracks reconstructions from South Shields in Britain and Saalburg in Upper Germany display structures with rather dim interior spaces, where hardly any activity would be possible without artificial lighting. Conversely, the question of lighting in the barracks has only rarely been addressed so far through the systematic analysis of the lighting devices associated with

these buildings.⁵⁵⁶ More recent studies have drawn attention to the fact that the use of oil lamps in a Roman provincial setting was not commonplace as previously thought, and in all probability alternative methods (torches, candles, dried pine branches and hearth light) were employed to a larger extent.⁵⁵⁷ While this view seems to be gaining increasing acceptance, the oil lamps represent by far the most significant archaeological evidence for artificial lighting in this period. The analysis of oil lamp usage on certain sites may prove instructive, as the use of these lighting implements displays a high degree of both spatial (i.e. between provinces and sites) and chronological variation, for which a wide range of possible explanations have been put forward so far. In a complex study by Hella Eckardt,⁵⁵⁸ the fluctuation of lamp usage and its distribution patterns according to military, civilian (i.e. large towns) and rural sites (i.e. small towns and countryside) is comprehensively analysed at the level of an entire province. Nevertheless, the significance of these changing patterns is not treated in terms of the effect it had on the lifestyle of individual military or civilian communities. Instead, emphasis is placed on the social and economic implications of artificial lighting and the relationship between the effects of ‘supply and availability’ on the one side, and the impact of cultural factors on the use of a typically Roman manner of artificial lighting, on the other.

Returning to Buciumi, the fact that the double barracks (nos. 2 and 5) yielded more than twice as many lamps as the simple ones (nos. 1 and 4) can be relevant with regard to the current discussion. However, the situation is complicated by the fact that barracks no. 5, which produced the most lamps, may not have functioned as living quarters during the entire course of the fort’s occupation, as suggested by the great number of crucibles, tools and slag discovered inside, by its unusual plan, and by the presence of several hearths.⁵⁵⁹ Actually, it contains more tools, lighting devices, arms and armour than any other excavated structure in the fort, but the outcome is at least partly due to the fact that it has yielded the most material. The high number of lamps could indeed point to the function of *fabrica*, at least during one of the fort’s phases. As for barracks no. 4 being a hospital or a stable, there is no evidence to support these views, and alternative functions were apparently put forward because an internal partition could not be clearly observed.⁵⁶⁰

The investigation so far has shown that the conspicuously low number of lamps discovered in the barracks of the fort was probably insufficient to provide alone a suitable amount of artificial light.⁵⁶¹ The use of alternative sources of light, as asserted in other cases, must be considered here as well, though there is little archaeological evidence to substantiate this. All the same, it is important to bear in mind, that while the formation of the archaeological record is indeed the result of a meaningful process (see the discussion in Chapter 4.1) when dealing with sites which ended with an organized abandonment – rather than a more or less sudden destruction – the quantitative analysis of artefacts such as lamps may not reflect the everyday realities of life within the analysed structures. Indeed, the process of abandonment must have greatly influenced both the spatial and the quantitative distribution of the artefacts.⁵⁶² Accordingly, it is safe to say that the amount of lamps discovered in the barracks is unrealistically low, and does not reflect an actual patterns of use.

Due to research deficiencies in this field, it is nearly impossible to establish chronological tendencies in the lamp usage inside the barracks. The compared figures from the military sites discussed in a survey of military ‘lamp consumption’ in Dacia, indicate some potential differences

⁵⁵⁶ With regard to Dacia see Petruț et al. 2014.

⁵⁵⁷ Eckardt 2002a; Eckardt 2002b, 15; Crnobrnja 2008, 409-411; Eckardt 2011.

⁵⁵⁸ Eckardt 2002a.

⁵⁵⁹ Chirilă et al. 1972, 57-58, 77-86; see also Landes-Gyemant/Gudea 2001, 147.

⁵⁶⁰ Gudea 1997b, 29.

⁵⁶¹ Petruț et al. 2014, 87.

⁵⁶² See Petruț et al. 2014, 82.



Figure 38. The 3D model of the 3.5 × 3.5 m chamber designed in Autodesk 3ds Max from different angles, with the points of interest where lighting was measured.

between the auxiliary and the legionary environment.⁵⁶³ The finds from the legionary fortress at Potaissa/Turda clearly show considerably more intensive lamp consumption compared with the auxiliary forts discussed. It is likely that this discrepancy is not simply a consequence of the difference in the dimensions of the respective military facilities, and might be connected with the idea that legionary fortresses have enjoyed a more prolonged and relatively constant olive oil supply. Studies regarding the situation from Britain have emphasized the low number of such lighting devices discovered in forts in general (and especially in the barracks), the internal structures with the highest rate of lamp finds being the hospital buildings (*valetudinaria*).⁵⁶⁴

The high number of lamps adapted to the use of tallow and other animal fats from the auxiliary fort at Buciumi could indicate a shortage in the olive oil supply. This phenomenon can be observed on a total of fifteen lamps, including all wheel-made lamps in addition to eight Firmalampen type pieces with enlarged filling holes by partial or total removal of the *discus* while already in use (e.g. Pl. 31/1, 2).⁵⁶⁵ A further important functional aspect is the presence of handles on some lamps, which were presumably produced with the intent to facilitate their portability and ‘mobile’ (‘on the move’) use, possibly even outside of the barracks.⁵⁶⁶ Only five such cases could be identified within the current assemblage, although this figure is clearly determined by the fragmentary nature of the material. It is a well-known fact that the only way to increase the oil lamps’ lighting efficiency was to increase the number of nozzles. The fact that only one such case can be identified in the present material indicates that there was only a minimal effort to increase the lamps’ efficiency by using the so-called *multilychnis* variants (e.g. Pl. 31/3).

The virtual light intensity simulations put forward in the aforementioned study have suggested that the lamps within the individual *contubernia* could not provide sufficient light for activities that required focus on detail (such as reading or gaming), even if these activities were centred in the

⁵⁶³ Petruț et al. 2014, *passim*.

⁵⁶⁴ Hodgson 2003, 140; Giles 2012, 60–61, Table 14.

⁵⁶⁵ Petruț et al. 2014, 83.

⁵⁶⁶ Eckardt 2011, 186.

immediate vicinity of two or more lamps hypothetically situated on a table. Even as the number of lamps was gradually increased, reaching in the end four simultaneously working pieces, the overall effect can be described as insubstantial (Figure 38). Light availability was highly localised and restricted to the immediate vicinity of the lamps. Based on this and previous enquiries on the subject, our view on the use of lamps can be slightly adjusted. It is fair to assume that oil lamps in the context of enclosed spaces, such as the *contubernia*, could not have ensured the continuation of day-time activities after sunset even if we consider the adaptability of the human eye, as well as the addition of alternative means of lighting. Therefore, the primary purpose of these items can be more adequately established as devices that facilitated orientation and movement within these rooms after dusk.⁵⁶⁷

⁵⁶⁷ Petruț et al. 2014, 84–87.

5 • The pottery small finds

5.1. Introduction

An exact definition of the concept of ‘small finds’ is difficult to put forward, approaches and opinions on what can and should be understood under this term do reveal occasionally a high degree of variety, especially between its use in published specialist reports and on-site finds registration and processing.⁵⁶⁸ The general picture that emerges from the publication of material assemblages, especially monographs, suggests that small finds comprise of objects possessing an intrinsic and individual informational value (in terms of function, chronology, and provenance), and hence are treated separately from well-established categories such as: the pottery assemblages, coins, CBM, archaeozoological assemblages, etc.⁵⁶⁹ At a closer look however, we see that the small find label is mostly a matter of quantity, and monograph chapters under this heading usually encompass a wide range of artefacts classified according to their material and brought together by their scarce representation within the studied material assemblage. The latter aspect effectively hinders the separate discussion of these artefacts based on functional and typological classifications, hence imposing a qualitative, rather than a quantitative approach. At a general level however, drawing on the abovementioned notion of intrinsic value, the small finds concept includes an extremely wide range of artefacts which excludes the ‘common’ – i.e. locally produced – pottery assemblages usually present in abundant quantities on Roman sites, ceramic building material (CBM), and animal bone assemblages.⁵⁷⁰ Depending on the quantity and proportion of certain imported pottery containers, such as terra sigillata, amphorae or certain thin-walled drinking vessels, these are either processed separately or together with the rest of the pottery assemblage.

The current chapter brings together a series of finds usually dissociated from the pottery assemblages in publications. Even though assessing functionality is probably the most important and most problematic aspect related to small finds, especially considering the ever-present possibility of multifunctional use,⁵⁷¹ the current material can be ascribed (with varied degrees of certainty) to a wide range of activities from metal-working (numerous crucibles and a casting mould piece), textile-making (spindle whorls), gaming (pottery counters), specific combat techniques (sling-shots) and possible cultic activities (terracotta statuette). Although pottery lamps do qualify as small finds, their assessment was integrated into the previous chapter due to their strong connection to pottery vessels over multiple aspects, such as production, distribution, and use (e.g. the question regarding the types of fuel employed and its connections to issues related to diet and food supply).

⁵⁶⁸ For a general methodology of small find studies, see Crummy 2007.

⁵⁶⁹ See for instance the structure of the monograph concerning the fort at Housesteads (Rushworth 2009). See also Gui 2012 (with the cited bibliography).

⁵⁷⁰ This is common practice on an increasing number of Roman sites across Europe and beyond.

⁵⁷¹ Gui 2012, 39–41.

5.2. Bronze casting tools

The present pottery assemblage yielded three new objects linked to bronze casting (in addition to the ones highlighted by the monograph)⁵⁷² comprised of two crucibles (74, 75) and a fragment of a casting mould (76). The crucibles display certain differences in shape, one of them being fitted with a spout. Traces of use are visible in both cases, the outer surface of the walls displaying signs of vitrification, while signs of bronze accumulation can be seen on the interior. With regard to the third object, it was probably part of a system of valves, employed for the lost-wax casting of certain bronze objects, which typically involved the use of composite moulds.⁵⁷³ The present fragment, based on its half-funnel shape, was probably used in conjunction with further two valves which together made up the upper part of the composite mould where the molten metal was poured. The piece displays a series of channels, some visible in cross-section, others being internal. Given that the elements of the mould's lower part are missing, it is difficult to assess the exact nature of the artefacts it was designed to produce. In all probability the mould was used and subsequently broken to recover the cast object, as suggested by the bronze accumulations found in the interior of the analysed piece.⁵⁷⁴ A similar mould was discovered in the workshops of the auxiliary fort at Housesteads on Hadrian's Wall, and according to the published specialist report it was most likely used for the production of spoons and brooches.⁵⁷⁵

In D.P. Davidson's comprehensive work on the barracks of the Principate, the author includes among the regular activities that took place in the barracks the repair and even the production of basic pieces pertaining to the military equipment of the soldiers.⁵⁷⁶ According to the evidence of the archaeological record, the existence of small workshops probably confined to the space of individual *contubernia* can be asserted in some, if not all barracks. Thus, the emergence of metalworking tools inside virtually all of the barracks in Buciumi should not be surprising. The excavations carried out over the period between 1963 and 1970 produced a total of thirty-three pottery crucibles, three of them intact. The overwhelming majority of finds come from Barracks no. 5 (eighteen fragments), with only one piece coming from structures other than the barracks. Furthermore, the fact that all of the comprehensively researched barracks (nos. 1, 2, 3, 4, 5) have produced such finds, seems to corroborate the fact that metal-working activities were not confined to an individual *fabrica* (if one existed in the fort at all), but were carried out in small workshops based in the barracks.

The finds catalogue:

74. Crucible. Pl. 32/4.

Unpublished. Dm. 40 mm, H. 46 mm, Th. 6 mm.

Barracks no. 2. X. 18–22 m, d. 0.6–1 m. 'Under the southern wall'.

Handmade pottery crucible, its body is cone-shaped and is fitted with a spout. The fabric is coarse, its outer surface displaying signs of vitrification, while bronze accumulation can be observed on the interior.

Inv. No. 330/1973, Mus. Zalău.

75. Crucible. Pl. 32/5.

Unpublished. Dm. 47 mm, H. 47 mm, Th. 11 mm, Lg. 45 mm.

⁵⁷² Chirilă et al. 1972, 57–58.

⁵⁷³ Bayley/Budd 1998, 195.

⁵⁷⁴ Bayley/Budd 1998, 195.

⁵⁷⁵ Dungworth/Starley 2009, 580–581, Fig. 20.1.

⁵⁷⁶ Davison 1989, 242.

Barracks no. 1. No further spatial information available.

Handmade pottery crucible, its body is globular with an inturned rim and thick walls. The fabric is coarse, its outer surface displaying signs of vitrification, while bronze accumulation can be observed on the interior.

Inv. No. 81/1979, Mus. Zalău.

76. Fragment (valve) of a composite mould. Pl. 32/3, 33/2.

Unpublished. H. 60 mm. Lg. 56 mm. Fabrics code: OC 2.

Barracks no. 1. No further spatial information available.

Inv. No. 396/1972, Mus. Zalău.

5.3. Pottery counters

The disc-shaped pottery objects carved from the walls or bases of discarded and subsequently recycled pottery vessels⁵⁷⁷ have been ascribed to a wide range of functions, although they are most often interpreted as gaming counters used in various dice games. Similar objects albeit more elaborately crafted from bone, glass or stone were most likely employed in a similar fashion. This is corroborated by the discovery in funerary context of sets of glass and bone counters in conjunction with wooden gaming boards.⁵⁷⁸ According to Lindsay Allason-Jones, the discs displaying diameters between 17 and 25 mm can be interpreted as gaming counters with a high degree of certainty.⁵⁷⁹ If one applies this standard to the material from Dacia however, the overwhelming majority of finds would need to be reassessed in terms of their functionality (see below). The presence of such finds is quite frequent on all categories of sites across the Roman Empire. Based on the evidence of shipwrecks from the Adriatic Sea it was suggested that similar pottery discs were employed as amphora stoppers. As the analysis of Theodore Peña shows however, in most cases the respective stoppers were made from amphora walls and displayed diameters in excess of 50 mm.⁵⁸⁰ All the same, it cannot be ruled out that such discs were in fact used as stoppers for various types of jugs and flagons. It is safe to say that without access to clear contextual data, the functional interpretation of these objects is somewhat equivocal, although the finds coming from the military environment often indicate a clear connection with gaming activities, as shown by the Ravenglass and Porolissum discoveries (see Chapter 1). Even so, a survey of such finds in Britain has revealed that the majority of pottery counters come from the headquarters buildings (*principia*) of the forts, contrary to our expectations the barracks yielding somewhat low numbers of such finds, compared to other structures of the forts.⁵⁸¹ The pottery discs coming from the *principia* are usually interpreted as accounting implements.⁵⁸²

In the case of Buciumi, the monograph has reported the discovery of thirty-four such pottery counters, according to the authors, five pieces being produced as such in pottery workshops, while the remainder were carved out of discarded vessels.⁵⁸³ The subsequent period (1971–76) has produced at least seventeen counters, all produced exclusively from the recycling of various containers. Unfortunately, only six pieces display inventory numbers, thus their exact place of discovery is not revealed. Given however that during the respective period excavations were confined to the barracks, all of the objects can be ascribed to these structures. Consequently, the distribution of

⁵⁷⁷ Peña 2007, 153–159.

⁵⁷⁸ Allason-Jones 2011, 234.

⁵⁷⁹ Allason-Jones 2011, 233–234.

⁵⁸⁰ Peña 2007, 154–58.

⁵⁸¹ Giles 2012, 60.

⁵⁸² Giles 2012, 60; Allason-Jones 2011, 234 (with the cited bibliography).

⁵⁸³ Chirilă et al. 1972, 58–59.

the total of fifty-one pottery counters discovered in the fort at Buciumi is as follows: thirty-seven pieces come from the four barracks researched extensively (see above), ten pieces were discovered in various other structures of the fort (the *praetorium*, the two side gates, the towers, and buildings nos. 1 and 4), while a further four pieces have unknown places of discovery (Figure 39). The massive prevalence of counters discovered in the barracks is in accordance with notions regarding the gaming activities carried out by soldiers most often in and around the barracks. In addition to the pottery counters, the monograph also includes nineteen carved bone discs – some of them perforated in the centre and decorated with concentric circles – also usually attributed to instances of gaming.⁵⁸⁴ Furthermore, the published material also includes fragments of pottery gaming boards,⁵⁸⁵ typically employed for the game known as *ludus latrunculorum*, very popular among the soldiers.⁵⁸⁶ Unfortunately there is no clear indication of the exact place of discovery in the case of the boards.

Certain technical observations are in place with regard to the present body of pottery counters, even though a classification of the fabrics was carried out only in the case of the hitherto unpublished seventeen pieces (see the catalogue below). It is probably not accidental that only ten out of the total of fifty-one counters were carved out of vessels fired in reducing environments, the vast majority being produced from oxidized vessels (Figure 40). It is even more conspicuous that a single piece (out of the unpublished seventeen) displays coarse fabrics, suggesting that it was carved out of a cooking vessel (pot, pan, or casserole). It might be implied that there was a preference – possibly of aesthetical nature – for vessels made from fine and semifine fabrics. Moreover, the majority of the present counters display linear protuberances created by the potters during wheel throwing, typical for the interior surface of closed forms such as jugs, flagons, jars, and pots. This apparent uniformity is in contradiction however with the needs of games such as *ludus latrunculorum* and *duodecim scripta*. One possible solution for this inconsistency could have been the alternate use of the counter's two sides, which displayed quite marked differences, especially in the case of the closed vessels.

*The finds catalogue:*⁵⁸⁷

77. Pottery counter. Pl. 33/1.

Fabrics code: RF 1. Dm. 50 mm, Th. 8 mm. The vessel displayed stamped decoration, the counter incorporating a stamped motif consisting of a column and a series of rosettes. Unpublished. Barracks no. 1. X. 8–9 m, Y. 0–4 m, d. 0.5 m. Inv. no. 658/1973, Mus. Zalău.

78. Pottery counter. Pl. 33/1.

Fabrics code: RC 3. Dm. 41 mm, Th. 5 mm. Carved from the body of a vessel. Unpublished. Unknown inv. no., no planimetric information.

79. Pottery counter. Pl. 33/1.

Fabrics code: OS 3. Dm. 43 mm, Th. 8 mm. Carved from the footring base of a small bowl or cup. Unpublished. Unknown inv. no., no planimetric information.

80. Pottery counter. Pl. 33/1.

Fabrics code: OS 1. Dm. 48 mm, Th. 9 mm. Carved from the body of a vessel. Unpublished.

⁵⁸⁴ Chirilă et al. 1972, 85.

⁵⁸⁵ Chirilă et al. 1972, 60.

⁵⁸⁶ Paki/Cociș 1993, 150–15.

⁵⁸⁷ All pieces were carved out of discarded pottery containers.

Unknown inv. no., no planimetric information.

81. Pottery counter. Pl. 33/1.

Fabrics code: OF 1. Dm. 41 mm, Th. 6 mm. Carved from the body of a vessel. Unpublished.
Unknown inv. no., no planimetric information.

82. Pottery counter. Pl. 33/1.

Fabrics code: OS 3. Dm. 42 mm, Th. 10 mm. Carved from the body of a vessel. Unpublished.
Unknown inv. no., no planimetric information.

83. Pottery counter. Pl. 33/1.

Fabrics code: OS 1. Dm. 45 mm, Th. 6 mm. Carved from the body of a vessel. Unpublished.
Unknown inv. no., no planimetric information.

84. Pottery counter. Pl. 33/1.

Fabrics code: OS 1. Dm. 41 mm, Th. 7 mm. Carved from the body of a vessel. Unpublished.
Unknown inv. no., no planimetric information.

85. Pottery counter. Pl. 33/1.

Fabrics code: OS 3. Dm. 37 mm, Th. 5 mm. Carved from the body of a vessel. Unpublished.
Barracks no. 2. X. 45–80 m, Y. 6–11 m, d. 1 m. Inv. no. 660/1973, Mus. Zalău.

86. Pottery counter. Pl. 33/1.

Fabrics code: RF 1. Dm. 26 mm, Th. 6 mm. Carved from the body of a vessel. Unpublished.
Unknown inv. no., no planimetric information.

87. Pottery counter. Pl. 33/1.

Fabrics code: OS 1. Th. 6. Unpublished.
Barracks no. 2. X. 35 m, Y. 45 m, d. 0.5–1.2 m. Inv. no. 404/1973, Mus. Zalău.

88. Pottery counter. Pl. 33/1.

Fabrics code: OS 2. Dm. 35 mm, Th. 7 mm. Carved from the footring base of a small bowl or cup.
Unpublished.
Barracks no. 2. X. 43–53 m, Y. 0–5.5 m, d. 0.8–1.5 m. Inv. no. 437/1973. Mus. Zalău.

89. Pottery counter. Pl. 33/1.

Fabrics code: OS 3. Dm. 44 mm, Th. 5 mm. Carved from the body of a vessel. Unpublished.
Unknown inv. no., no planimetric information.

90. Pottery counter. Pl. 33/1.

Fabrics code: RS 1. Dm. 44 mm, Th. 5 mm. Carved from the body of a vessel. Unpublished.
Unknown inv. no., no planimetric information.

91. Pottery counter. Pl. 33/1.

Fabrics code: RS 1. Dm. 22 mm, Th. 7 mm. Carved from the body of a vessel. Unpublished.
Unknown inv. no., no planimetric information.

92. Pottery counter. Pl. 33/1.

Fabrics code: OF 1. . Dm. 45 mm, Th. 7 mm. Carved from the body of a vessel. Unpublished.
Barracks no. 1. X. 43–46 m, Y. 0–4 m, d. 1 m. Inv. no. 647/1973, Mus. Zalău.

93. Pottery counter. Pl. 33/1.

Fabrics code: OF 1. Dm 30 mm, Th. 5 mm. Carved from the body of a vessel. Unpublished.

Barracks no. 1. X. 15–16 m, Y. 3 m. 'Balk no. 1 from the daub layer'. Inv. no. 409/1973, Mus. Zalău.

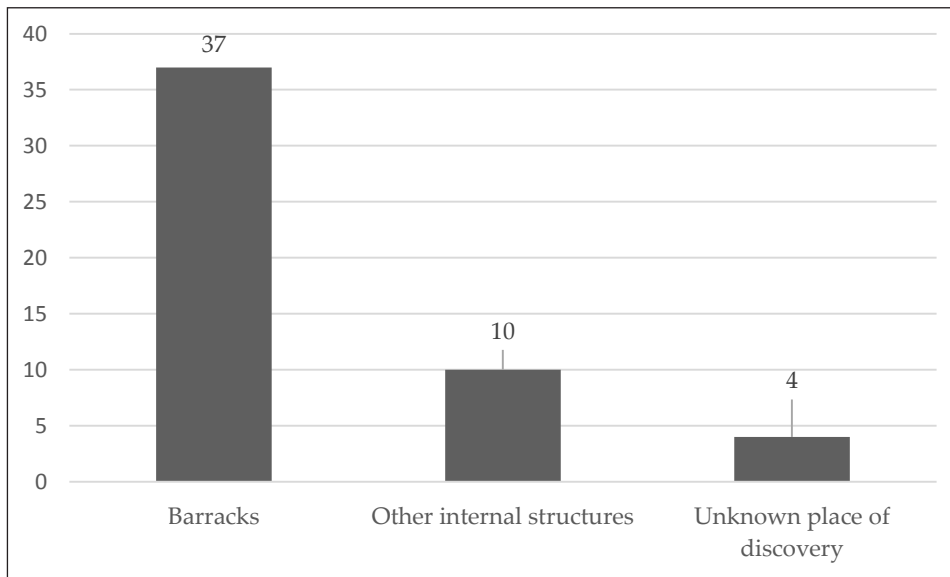

Figure 39. The spatial distribution of the pottery counters.

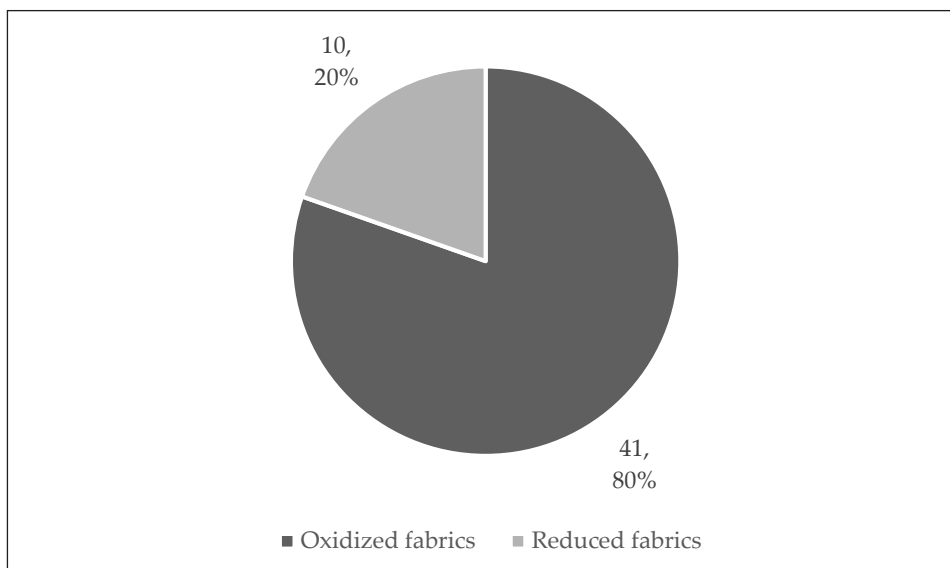

Figure 40. The compared proportion of oxidized and reduced fabrics.

5.4. Pottery sling-shots (*glandes*)

The pottery sling-shots are probably among the most ignored small finds in the Roman military environment. Even so, at Buciumi a fairly consistent group of objects was published in the 1972 monograph to which a further lot of hitherto unpublished finds can be added here. It was claimed that professional slingers (*funditores*) were introduced to the Roman army as a result of influence from Greek military arts which had a long tradition of employing the sling (*funda*) on the battlefield.⁵⁸⁸ As we know, there is no epigraphic evidence for the existence of units specialized in the said fighting technique, there is however a rich array of literary sources describing the skills

⁵⁸⁸ Greep 1987, 189–190.

of slingers from various parts of the Empire, the most accolades being awarded to the natives of the Balearic Islands.⁵⁸⁹ The archaeological record – especially the distribution of the related finds – suggests that this fighting technique was employed by both the legions and the auxiliary units.⁵⁹⁰ Even so, it seems that only certain units incorporated slingers, as only a limited number of forts and fortresses have produced evidence for the use of such weapons. Furthermore, the primary use of slings for hunting cannot be entirely ruled out. It was also suggested that the employment of this fighting technique was more widespread in the eastern regions of the Empire especially since some six thousand pottery sling-shots were discovered in the legionary fortress at Lambaesis in North Africa.⁵⁹¹ During the Republic it would appear that the use of lead plummet was commonplace, their deadly efficiency being noted by the some ancient authors.⁵⁹² This practice however may have mostly been abandoned during the Principate, as evidence for the use of lead projectiles after the mid-1st century AD has only been produced by excavations in Britain.⁵⁹³ It is safe to say that pottery sling-shots began to be intensely used after the said period. In terms of shape and size, the pottery projectiles clearly rely on their lead prototypes, most pieces having a rhomboidal cross-section – effectively resulting in almond-shaped objects – in similar fashion with S.J. Greep's Type One lead missiles.⁵⁹⁴ Furthermore, acorn-shaped and spherical variants can also be noted, however these can be explained in terms of production flaws whereby the craftsmen failed to produce the desired shape. Even so, this does not seem to have hindered their use. The pottery projectiles from Buciumi were handmade from almost pure clay with no added tempers, usually applied around a small pebble which constituted the core of the object, thus increasing its weight.⁵⁹⁵

A classification of the sling-shots according to their material would include the following three categories: lead-, pottery-, and stone missiles. The latter usually consist of unworked water-worn pebbles of suitable size, rarely also including projectiles carved from certain easily workable rocks, such as limestone.⁵⁹⁶ Needless to say, the identification of sling-stones is highly problematic, and only in instances when they are associated contextually in larger numbers, preferably together with pottery or lead missiles, can they be confidently classified as such.⁵⁹⁷ The 1972 monograph includes forty-four sling-shots, eight of which consisting of pebbles and limestone splinters, the rest being made from pottery.⁵⁹⁸ The current survey has produced an extra twenty-seven unpublished pieces (twenty pottery pieces and seven stone ones). In terms of the shapes, all of the three abovementioned variants can be observed, and while assessing their shape involves a high degree of relativity, it is probably safe to say that most pieces belong to the acorn-shaped types. It is interesting to note that most pieces have preserved the fingerprints of the craftsmen. The fabrics were not classified, as they differ from the material of the vessels, lacking the tempers which were essential to the production and use of pottery containers. In terms of the firing, once again a prevalence of the oxidized objects can be noted, as only twelve of the fifty pottery projectiles discovered in the fort were fired in a reducing environment (Figure 42).

In terms of the projectile's spatial distribution it is important to note that among the total seventy-one finds – incorporating both the published and unpublished pottery and stone pieces – only three come from structures other than the barracks in addition to six objects with unknown

⁵⁸⁹ Greep 1987, 192.

⁵⁹⁰ Griffiths 1989, 269–271.

⁵⁹¹ Griffiths 1989, 258.

⁵⁹² Griffiths 1989, 267–269.

⁵⁹³ Greep 1987, 190; Griffiths 1989, 258.

⁵⁹⁴ Greep 1987, 191.

⁵⁹⁵ Griffiths 1989, 258.

⁵⁹⁶ Griffiths 1989, 258.

⁵⁹⁷ Griffiths 2009, 482.

⁵⁹⁸ Chirilă et al. 1972, 65–66.

place of discovery. All of the extensively researched barracks have produced sling-shots, barracks nos. 4 and 5 yielding the highest quantities with eighteen and seventeen finds (Figure 41). Given the relatively high number of finds directly linked to the fighting technique of the *funditores*, it is theoretically possible to interpret this as a typical feature of a unit recruited in Britain, i.e. the Cohors II Nervia Brittonum, given the apparent affinity of the respective province's army for this fighting technique. All the same, the fact that local recruitment changed the ethnic composition of the unit during its spell in Lower Pannonia and Dacia also has to be taken into consideration, therefore the only possibility for it to maintain its original fighting characteristics was through tradition.

*The finds catalogue:*⁵⁹⁹

94. Pottery sling-shot. Pl. 33/3.

Rhomboidal section. H. 35 mm, Lg. 34 mm. Oxidized firing. Unpublished.
Barracks no. 1. X. 42 m, Y. 4 m, d. 0.8 m. Inv. no. 166/1973, Mus. Zalău.

95. Pottery sling-shot. Pl. 33/3.

Rhomboidal section. H. 41 mm, Lg. 34 mm. Reduced firing. Unpublished.
Barracks no. 1. X. 42 m, Y. 4 m. Inv. no. 166/1973. Mus. Zalău.

96. Pottery sling-shot. Pl. 33/3.

Rhomboidal section. H. 39 mm, Lg. 33 mm. Oxidized firing. Unpublished.
Without planimetric data. No. inv. no. Mus. Zalău.

97. Pottery sling-shot. Pl. 33/3.

Rhomboidal section. H. 43 mm, Lg. 42 mm. Oxidized firing. Unpublished.
Without planimetric data. No. inv. no. Mus. Zalău.

98. Pottery sling-shot. Pl. 33/3.

Acorn-shaped. H. 49 mm, Lg. 38 mm. Oxidized firing. Unpublished.
Barracks no. 1. Without exact planimetric data. Inv. no. 560/1973. Mus. Zalău.

99. Pottery sling-shot. Pl. 33/3.

Rhomboidal section. H. 38 mm, Lg. 39 mm. Reduced firing. Unpublished.
Barracks no. 1. Without exact planimetric data. Inv. no. 560/1973. Mus. Zalău.

100. Pottery sling-shot. Pl. 33/3.

Rhomboidal section. H. 39 mm, Lg. 34 mm. Oxidized firing. Unpublished.
Barracks no. 1. Without exact planimetric data. Inv. no. 560/1973. Mus. Zalău.

101. Pottery sling-shot. Pl. 33/3.

Rhomboidal section. H. 44 mm, Lg. 44 mm. Oxidized firing. Unpublished.
Barracks no. 2. X. 10 m. 'Under the southern wall'. Inv. no. 343/1973. Mus. Zalău.

102. Pottery sling-shot. Pl. 33/3.

Acorn-shaped. H. 35 mm, Lg. 34 mm. Oxidized firing. Unpublished.
Barracks no. 2. d. 0.5–1 m. 'Under the southern wall'. Inv. no. 332/1973. Mus. Zalău.

⁵⁹⁹ For the sake of extensiveness, in addition to the pottery projectiles, the stone sling-shots were also included in the catalogue below.

- 103.** Pottery sling-shot. Pl. 33/3.
Rhomboidal section. H. 40 mm, Lg. 35 mm. Reduced firing. Unpublished.
Without precise planimetric data. Inv. no. 283/1973. Mus. Zalău.
- 104.** Pottery sling-shot. Pl. 33/3.
Spherical. Dm. 30 mm. Oxidized firing. Unpublished.
Barracks no. 1. X. 16 m, Y. 2 m, d. 1 m. Inv. no. 613/1973. Mus. Zalău.
- 105.** Pottery sling-shot. Pl. 33/3.
Spherical. Dm. 32 mm. Oxidized firing. Unpublished.
Barracks no. 2. d. 1.2–1.4. Without precise planimetric data. Inv. no. 414/1973. Mus. Zalău.
- 106.** Pottery sling-shot. Pl. 33/3.
Rhomboidal section. H. 34 mm, Lg. 31 mm. Oxidized firing. Unpublished.
X. 5.8 m, Y. 11 m, d. 0.5 m. 'Near the *via sagularis*'. Inv. no. 597/1973. Mus. Zalău.
- 107.** Pottery sling-shot. Pl. 33/3.
Rhomboidal section. H. 38 mm, Lg. 34 mm. Oxidized firing. Unpublished.
X. 5.8 m, Y. 11 mm, d. 0.5 mm. 'Near the *via sagularis*'. Inv. no. 597/1973. Mus. Zalău.
- 108.** Pottery sling-shot. Pl. 33/3.
Rhomboidal section. H. 37 mm, Lg. 34 mm. Oxidized firing. Unpublished.
Without precise planimetric data. Inv. No. 276/1973. Mus. Zalău.
- 109.** Pottery sling-shot. Pl. 33/3.
Spherical. Dm. 36 mm. Oxidized firing. Unpublished.
Without precise planimetric data. Inv. no. 276/1973. Mus. Zalău.
- 110.** Pottery sling-shot. Pl. 33/3.
Acorn-shaped. H. 47 mm, Lg. 38 mm. Oxidized firing. Unpublished.
Barracks no. 1. d. 0.6 m. 'Transversal balk no. 1'. Inv. no. 327/1973. Mus. Zalău.
- 111.** Pottery sling-shot. Pl. 33/3.
Acorn-shaped. H. 35 mm, Lg. 25 mm. Oxidized firing. Unpublished.
Barracks no. 1. d. 0.6 m. 'Transversal balk no. 1'. Inv. no. 327/1973. Mus. Zalău.
- 112.** Pottery sling-shot. Pl. 33/3.
Acorn-shaped. H. 35 mm, Lg. 33 mm. Reduced firing. Unpublished.
Barracks no. 1. X. 45–48 m, Y. 4–8 m, d. 1.5 m. Inv. no. 326/1973 m. Mus. Zalău.
- 113.** Pottery sling-shot. Pl. 33/3.
Acorn-shaped. H. 38 mm, Lg. 33 mm. Reduced firing. Unpublished.
Barracks no. 2. X. 13 m, Y. 13–14 m, d. 0.8 m. Inv. no. 523/1973. Mus. Zalău.
- 114.** Stone sling-shot. Pl. 33/3.
Acorn-shaped, worked limestone. H. 37 mm, Lg. 35 mm. Unpublished.
Barracks no. 2. d. 1.5 m. 'Near the *via sagularis*'. Inv. No. 405/1973. Mus. Zalău.
- 115.** Stone sling-shot. Pl. 33/3.

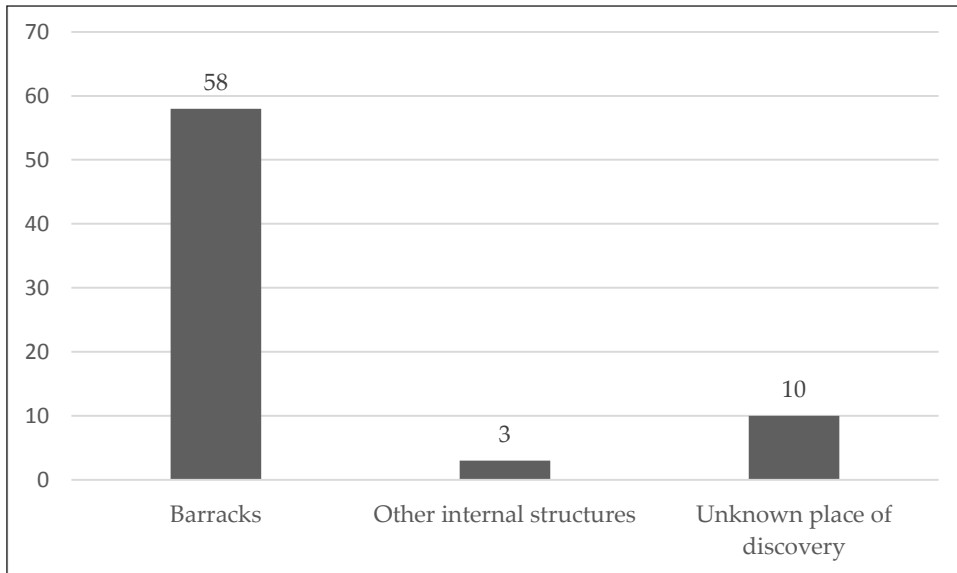

Figure 41. The spatial distribution of sling-shots.

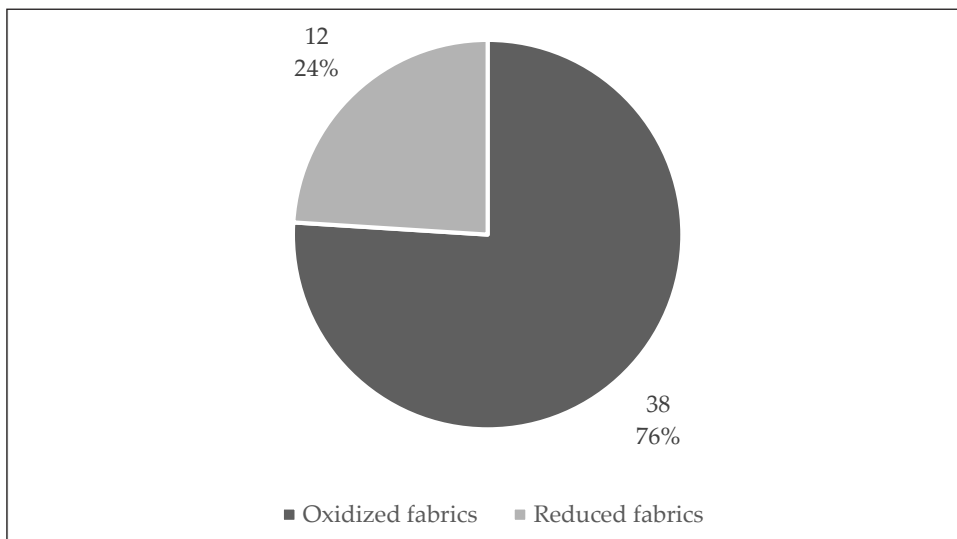

Figure 42. The compared proportion of oxidized and reduced fabrics (pottery sling-shots).

Acorn-shaped, worked limestone. H. 41 mm, Lg. 35 mm. Unpublished.
Barracks no. 2. 'Near the *via sagularis*'. Inv. no. 408/1973. Mus. Zalău.

116. Stone sling-shot. Pl. 33/3.

Acorn-shaped, worked limestone. H. 40 mm, Lg. 36 mm. Unpublished.
Barracks no. 1. d. 0.6 m. 'Transversal balk no. 1'. Inv. no. 327/1973. Mus. Zalău.

117. Stone sling-shot. Pl. 33/3.

Acorn-shaped, unworked pebble. H. 40 mm, Lg. 30 mm. Unpublished.
Barracks no. 1. X. 16 m, Y. 31 m, d. 0.8 m. Inv. no. 451/1973. Mus. Zalău.

118. Stone sling-shot. Pl. 33/3.

Rhomboidal section, worked limestone. H. 28 mm, Lg. 22 mm. Unpublished.
Barracks no. 1. M1. 32-49 m, M2. 4-8 m, d. 0.6-0.8 m. Inv. no. 317/1973. Mus. Zalău.

119. Stone sling-shot. Pl. 33/3.

Acorn-shaped, worked limestone. H. 34 mm, Lg. 26 mm. Unpublished.
Barracks no. 1. X. 16–31 m, Y. 4–8 m, d. 0.6–0.8 m. Inv. no. 460/1973. Mus. Zalău.

120. Stone sling-shot. Pl. 33/3.

Unworked pebble. Acorn-shaped. H. 41 mm, Lg. 38 mm. Unpublished.
Without exact planimetric data. No. inv. no. Mus. Zalău.

5.5. Spindle whorls

Spindle whorls, used in the process of wool spinning are usually reported under the form of perforated circular pottery objects, either discs similar to the counters (see above) or truncated bicones. Despite their frequent emergence within the material assemblages of forts and fortresses, their functionality was often deemed to be inconsistent with the traditional views regarding the military lifestyle inside these bases.⁶⁰⁰ All the same, their presence in the military environment is in accordance with the recurrent production and repair activities taking place here, which surely included work with textiles as well. The finds catalogue of the 1972 monograph contains a total of seven such finds, all but one coming from the barracks.⁶⁰¹ Subsequent research has produced two further finds bringing the total to nine objects. Their distribution across the barracks is as follows: barracks no. 1: one, barracks no. 2: three, barracks no. 5: one, barracks no. 5: three.

The finds catalogue:

121. Spindle whorl. Pl. 32/7.

Truncated bicone shape, handmade. Dm. 40 mm, H. 26 mm, hole: 70 mm. Reduced firing, coarse fabric (inclusions: frequent medium size quartz and calcite grains), dark grey colour. Unpublished.
Barracks no. 1, d. 0.5 m. Without precise planimetric data. Inv. no. 84/1971. Mus. Zalău.

122. Spindle whorl. Pl. 32/6.

Pottery disc crudely cut from a vessel. Dm. 70 mm, Lg. 63 mm, Th. 11 mm. Fabrics code: RC 2. Traces of strong secondary burning. Unpublished.
Barracks no. 2, d. 0.5 m. Without precise planimetric data. Inv. no. 298/1973. Mus. Zalău.

5.6. Terracotta figurines

The finds catalogue of the monograph includes a total of five terracotta (pipeclay) figurines.⁶⁰² Only one additional unpublished object can be added here at this time, the respective mouldmade statuette displaying a somewhat poor depiction of Venus. The features of the figurine, especially its compact, static shape and lack of details, suggest that it was produced in a single bi-valve mould,⁶⁰³ which must have been quite worn, judging from the lack of detail on the statuette. The iconographic type characterised by the standing figure of the goddess holding a wreath in her left hand was identified as a variant of the 'Venus of Cnidus' type, two close analogies – albeit both of considerably better quality – coming from the auxiliary fort at Gherla.⁶⁰⁴

The affinity of soldiers for the cult of Venus is well-known, and is reflected in archaeological terms primarily in the high number of terracotta, bronze and marble figurines depicting the

⁶⁰⁰ See the discussion in Vass 2010, 128–132, 137–138.

⁶⁰¹ Chirilă et al. 1972, 59.

⁶⁰² Chirilă et al. 1972, 107–108.

⁶⁰³ Higgins 1976, 105–106.

⁶⁰⁴ Antal 2012, 102, Nr. 18, 19, Pl. IV/2, 4;

goddess, found in military bases, especially in the barracks.⁶⁰⁵ Judging from the archaeological record, we are most certainly dealing with private (possibly votive) manifestations of the soldiers' devotion for the divinity, who was also known to be a protector against death.⁶⁰⁶

The finds catalogue:

123. Terracotta (pipeclay) figurine depicting the goddess Venus. Pl. 34/1a–b.

H. 130 mm, Th. 8 mm, Lg. 52 mm. No colour-coating. Traces of strong secondary burning. Unpublished.

The figure is half-nude on a pedestal. It wears a diadem or a veil on its head, holding a wreath in her left hand and an unidentifiable object in the other.

Barracks no. 1. X. 17 m, Y. 5 m, d. 0.6 m. Inv. no. 161/1973. Mus. Zalău.

⁶⁰⁵ Antal 2012, 92–93.

⁶⁰⁶ Antal 2012, 102, 98.

6. Conclusions. Pottery and everyday life in the fort at Buciumi

As already mentioned at the beginning, the present study can be most effectively described as an attempt at exploring the most suitable means of analysing a pottery assemblage with low resolution contextual data according to a set of aspects that are potentially indicative of the realities behind the day-to-day functioning and cohesion mechanisms of a community of auxiliary soldiers. These aspects converge on the questions of 1) supply of goods to the fort, i.e. the 'local' pottery production, probably based in the civilian settlement (*vicus*) founded in the vicinity of the fort and meant to meet the needs of the local garrison (see the case of the so-called 'legionary ware'), the import of mostly Gaulish and Rhenish finewares (*sigillata*), combined with what was probably occasional imports of Raetian (Westerdorf) and Italian *sigillata*, pottery lamps from Poetovio, and probably North Italian thin-walled vessels, in addition to the import of typically Mediterranean amphora-borne commodities, such as olive oil and wine; 2) culinary activities (military diet) and conviviality among the troops; 3) day-to-day activities within the garrison (e.g. cult-related pursuits), including the prerequisites for any kind of sustained activity within the barracks, namely the supply of artificial lighting.

Regarding the question of pottery supply (i.e. local production and imports), not surprisingly the bulk of the material can be ascribed to the local industry, the imported fineware accounting for a small percentage of the assemblage. Furthermore, certain elements within the material seem to be consistent with the category of so-called 'legionary ware', which, for the sake of accuracy, should be referred to as 'military ware' or 'military pottery'. The possibility of viewing this much-discussed category in terms of functionality and manner of use should also be considered. The lifestyle, the communal military identity and the social environment of the Roman military base certainly determined to a great extent the choice of material culture and its manner of use. Introducing these aspects may help the better understanding of legionary ware. The popularity of the bowls based on the Drag. 44 form (type BO 2 in the current assemblage), generally large vessels with wide mouth openings, may have been influenced by the practice of communal eating in the *contubernia* of the barracks. Furthermore, the imitation of bronze vessels linked with washing and bathing activities such as the 'washing basin' (*Waschbecken*) and the hand-washing set, the so-called '*Kanne und Griffschale*' may be indeed related with the pronounced propensity for hygiene of the Roman army.

With regard to the terra *sigillata* imports, the bulk of the material comes from Central Gaulish producers, based mainly at Lezoux, although the XRF analysis has revealed the existence of vessels produced in the South Gaulish centre at La Graufesenque. With regard to the chronological distribution of the assemblage, it is evident that period III, covering the latter half of the 2nd century AD, is by far the most well-represented, probably accounting for a peak in the supply of terra *sigillata* to the fort. The review of the material's spatial distribution, although the available data is limited, has revealed the tendency of the finds concentrating in the centurion's quarter, suggesting

perhaps that these products were more accessible to the officers than the rank and file. A similar situation can be asserted with regard to the amphorae, which are present in conspicuously low numbers.

As to the question of military diet and conviviality, the quantification of the vessels belonging to the tableware has revealed a clear predisposition for food consumption from so-called 'communal vessels', consisting mainly of bowls with wide mouth openings. Accordingly, studies based especially on various types of terra sigillata have pinpointed the phenomenon whereby the overall dimensions and especially the mouth opening of the dishes and bowls tend to increase starting with the late-2nd century in unison with the general drop in the production of sigillata throughout the Empire. This tendency was also linked with the changes occurring in the practice of conviviality illustrated by the consumption of meals from communal vessels. With regard to the culinary activities within the barracks, the composition of the cookware category reveals that over half of the cooking vessels are represented by pans, while the proportion of casseroles is the lowest. Given the high number of pans and pots, as well as the fact that they were clearly used for the preparation of different types of meals, it is possible that the two vessel types were assigned complementary purposes within cooking sets, possibly together with certain meal containers.

Very little evidence can be cited with regard to the cultic activities within the barracks beyond the existence of the pottery incense burners (*turibula*), while the exact function of the miniature vessels is open for debate. On the other hand, a closer look at the lamp finds, correlated with virtual lighting simulations, has revealed some potentially relevant information with regard to the question of light availability inside the barracks. Based on this, and previous enquiries on the subject, our view on the use of lamps can be slightly adjusted. It is fair to assume that the oil lamps in the context of enclosed spaces, such as the *contubernia*, could not have ensured the continuation of day-time activities after sunset even if we consider the adaptability of the human eye, as well as the addition of alternative means of lighting. Therefore, the primary purpose of these items can be more adequately established as devices that facilitated orientation and movement within these rooms after dusk. Furthermore, the artefacts included under the heading 'small finds' further present instances of metal-working, textile-making, gaming, the employment of specific fighting techniques, and possible cultic activities.

All in all, it is fair to say that despite the lack of high resolution contextual data, the pottery assemblage discussed throughout the present study can be effectively used for putting forward answers and assertions for questions regarding the daily life of Roman soldiers stationed in this part of the Empire. It is also reasonable to say that this seems only possible against the backdrop of the historical (and partly archaeological) narrative produced by the review of the sub-literary record. While we are aware that 'hammering' together the historical and archaeological narratives does not result in the emergence of a unified and valid discourse, in such cases the direct written evidence produced by the military communities can offer a foundation for the better understanding of disjointed archaeological assemblages. Furthermore, while throughout the book there is constant reference to various social, economic and political phenomena and changes occurring at any one time at the level of the Empire, and their possible correlations with some traits of the assemblage under scrutiny, it should not be forgotten that every assertion made here possesses first and foremost a local relevance, and is revealing with regard to the military community based at Buciumi. At any rate, insofar as this book has managed to show that there is more potential in the study of similar assemblages than usually acknowledged, its main goal has been reached.

List of figures

- Figure 1.** The plan of a typical auxiliary barracks block during the 2nd–3rd centuries AD (after Johnson 1983).
- Figure 2.** 3D model of a 3.5 × 3.5 m barracks chamber (*contubernium*) designed in Autodesk 3ds Max (Petruț et al. 2014, 87, fig. 12). Author: Horea Trîncă.
- Figure 3.** The main stages of the barracks' research history in the auxiliary fort at Buciumi.
- Figure 4.** The distribution of the main groups of vessels within the assemblage.
- Figure 5.** The distribution of the vessels based on the type of firing employed (oxidised wares and reduced wares).
- Figure 6.** The distribution of the main fabrics categories within the group of oxidised wares.
- Figure 7.** The distribution of the main fabrics categories within the group of reduced wares.
- Figure 8.** The proportion of oxidised/reduced wares according to the main functional categories.
- Figure 9.** The distribution of the fabrics categories according to the main functional groups.
- Figure 10.** The distribution of the main vessel classes within the category of tableware.
- Figure 11.** The distribution of BO 2 type 'bowls with central cordon', based on terra sigillata form Drag. 44.
- Figure 12.** The distribution and proportion of bowls derived from terra sigillata forms.
- Figure 13.** The distribution and proportion of dishes derived from terra sigillata forms.
- Figure 14.** The distribution of forms within the category of terra sigillata.
- Figure 15.** The distribution of the terra sigillata vessels according to production centres.
- Figure 16.** The chronological distribution of the terra sigillata vessels.
- Figure 17.** The spatial distribution of the terra sigillata vessels discovered in Barracks no. 2.
- Figure 18.** The spatial distribution of the terra sigillata vessels discovered in Barracks no. 1.
- Figure 19.** The distribution of vessel classes within the category of utilitarian ware.
- Figure 20.** Jugs and storage vessels published in the 1972 monograph (Chirilă et al. 1972, Pl. XXVIII).
- Figure 21.** Jugs and storage vessels published in the 1972 monograph (Chirilă et al. 1972, Pl. XXVII).
- Figure 22.** Jars/pots published in the 1972 monograph (Chirilă et al. 1972, Pl. IV).
- Figure 23.** The distribution of amphora types.
- Figure 24.** The distribution of vessel classes within the category of cookware.
- Figure 25.** The distribution of forms within the class of pans (PA).
- Figure 26.** Pans published in the 1972 monograph (Chirilă et al. 1972, Pl. XX).
- Figure 27.** The spatial distribution of incense burners (*turibula*).
- Figure 28.** The distribution of lamp types.
- Figure 29.** The spatial distribution of pottery lamps.
- Figure 30.** The classification of pottery lamp forms from Roman Dacia (based on Petruț et al. 2014, 80, Fig. 9).
- Figure 31.** A reconstructed face pot published in the 1972 monograph (Chirilă et al. 1972, Pl. LII–LIII).
- Figure 32.** The distribution of functional categories within the assemblage.
- Figure 33.** The distribution of 'communal vessels' (mouth Dm. over 300 mm) within the category of tableware.

Figure 34. The composition of 'communal vessels'.

Figure 35. Pottery 'saucepan' handles published in the 1972 monograph (Chirilă et al. 1972, Pl. XXXVII).

Figure 36. The distribution of pots according to the mouth openings (Dm.).

Figure 37. The distribution of pans according to the mouth openings (Dm.).

Figure 38. The 3D model of the 3.5 × 3.5 m chamber designed in Autodesk 3ds Max from different angles, with the points of interest where lighting was measured (Petruț et al. 2014, 86, Fig. 11).
Author: Horea Trîncă.

Figure 39. The spatial distribution of the pottery counters.

Figure 40. The compared proportion of oxidized and reduced fabrics (pottery counters).

Figure 41. The spatial distribution of slingshots.

Figure 42. The compared proportion of oxidized and reduced fabrics (pottery slingshots).

List of plates

- Plate 1.** The map of Roman Dacia based on the latest surveys, the fort at Buciumi being situated on the north-western sector of the Limes of Dacia Porolissensis. The permanent frontier line of the province is rendered with red. Source: <https://limesromania.ro/>.
- Plate 2.** The plan of the fort, redrawn after Gudea/Landes 1981. A: the headquarters building (*principia*); B 1–6: the barracks; C 1–2: storage buildings; C 3–4: the commanders' residence (*praetorium*); C 5–6: the granaries (*horrea*).
- Plate 3.** The plan of barracks nos. 1 and 2 during the three identified construction/habitation phases (1a, 1b, and 2). Redrawn after Gudea 1997b.
- Plate 4.** The classification of the bowls (BO). 1–2: type BO 1; 3–4: type BO 2.
- Plate 5.** The classification of the bowls (BO). 1: type BO 3; 2: type BO 4; 3: type BO 5; 4: type BO 6; 5: type BO 7; 6: type BO 1.
- Plate 6.** The classification of the bowls (BO). 1: type BO 1 with cut-glass decoration; 2: type BO 8; 3: type BO 9; 4: type BO 10; 5: possible bowl (unclassified).
- Plate 7.** The classification of the dishes (DI). 1–2: type DI 1 (no. 1 depicts a vessels displaying an ownership inscription, after Dana/Petruț 2015); 3–4: type DI 2; 5: type DI 3.
- Plate 8.** The classification of the dishes (DI), platters (PL), beakers (BE), and cups (CU). 1: type DI 4; 2: type DI 5; 3: type PL 1; 4: type BE 1; 5–6: type CU 1; 7: type CU 2; 8: type CU 3.
- Plate 9.** Relief-decorated terra sigillata vessel fragments discovered between 1963 and 1970 (after Isac 1977). The catalogue numbers are given in brackets.
- Plate 10.** Terra sigillata vessel fragments with potter's stamps discovered between 1963 and 1970, in addition to a restored intact container (8) and a roulette-decorated fragment (9) (after Isac 1977). The catalogue numbers are given in brackets.
- Plate 11.** Drag. 37 type bowl produced at Les Martres-de-Veyre (after Petruț 2014). The catalogue number is given in brackets.
- Plate 12.** Relief-decorated terra sigillata vessel fragments discovered between 1971 and 1976. The catalogue numbers are given in brackets.
- Plate 13.** Drag. 37 type terra sigillata vessel fragments discovered between 1971 and 1976. The catalogue numbers are given in brackets.
- Plate 14.** Terra sigillata plainware vessel fragments discovered between 1971 and 1976. The catalogue numbers are given in brackets.
- Plate 15.** Barbotine-decorated (1) and plainware terra sigillata vessel fragments discovered between 1971 and 1976. The catalogue numbers are given in brackets.
- Plate 16.** Terra sigillata plainware vessel fragments, thin-walled (8), and lead-glazed vessels (9 and 10) discovered between 1971 and 1976. The catalogue numbers are given in brackets.
- Plate 17.** Relief-decorated terra sigillata vessel fragments discovered between 1971 and 1976. The catalogue numbers are given in brackets.
- Plate 18.** Barbotine-decorated (8) and plainware terra sigillata vessel fragments discovered between 1971 and 1976. The catalogue numbers are given in brackets.

- Plate 19.** Terra sigillata plainware vessel fragments discovered between 1971 and 1976, in addition to fragments of lead-glazed ware (8) and local cut-glass-decorated tableware (9, 10). The catalogue numbers are given in brackets.
- Plate 20.** The classification of the jugs (JU). 1: type JU 3; 2: type JU 2; 3: type JU 3; 4: type JU 4; 5: type JU 5; 6: type JU 6; 7: type JU 7.
- Plate 21.** The classification of the jugs (JU) and flagons (FL). 1: type JU 8; 2: type JU 9; 3: type JU 10; 4: type FL 1; 5: type FL 2.
- Plate 22.** The classification of the flagons (FL) and jars (JA). 1: type FL 3; 2: type FL 4; 3: type FL 5; 4: type FL 6; 5: type FL 7; 6: type FL 8; 7: type FL 9; 8: type JA 1; 9: type JA 2; 10: type JA 3; 11: type JA 4.
- Plate 23.** The classification of the *dolia* (DO). 1: type DO 1; 2: type DO 2; 3: type DO 3; 4: type DO 4; 5: type DO 5; 6: type DO 6.
- Plate 24.** The classification of the strainers (ST) and *mortaria* (MO). 1: strainer wall fragment (unclassified); 2: type ST 1; 3–4: type ST 2; 5: type MO 1; 6: type MO 2; 7: type MO 3.
- Plate 25.** The classification of the amphorae. 1: Aquincum 78; 2–3: Dressel 6B; 4–5: Zeest 90/Dressel 24. The catalogue numbers are given in brackets.
- Plate 26.** The classification of the amphorae. 1: Aquincum 78; 2–3: Dressel 6B; 4–5: Zeest 90/Dressel 24. The catalogue numbers are given in brackets.
- Plate 27.** The classification of the pots (PO). 1: type PO 1; 2: type PO 2; 3: type PO 3; 4: type PO 4; 5: type PO 5; 6: type PO 6; 7: type PO 7; 8: type PO 8.
- Plate 28.** The classification of the casseroles (CA). 1: type CA 1; 2: type CA 2; 3: type CA 3; 4: type CA 4; 5: type CA 5.
- Plate 29.** The classification of the pans (PA). 1–2: type PA 1; 3: type PA 2; 4: type PA 3; 5: type PA 4; 6–7: type PA 5; 8: type PA 6; 9: type PA 7.
- Plate 30.** Non-food-related containers. 1: hemispherical washing basin; 2–5: incense burners (*turibula*); 6: miniature beaker. The catalogue numbers are given in brackets.
- Plate 31.** The main lamp types discovered between 1963 and 1970 (after Gudea/Cosma 2008). 1–3: Firmalampen (Loeschcke type IX–X); 4–5: Provincial ‘pear-shaped’ lamps; 6: Picture lamp fragment; 7–8: wheel-made lamps; 9: provincial Loeschcke type II lamp; 10: imported Loeschcke type I lamp with inscription; 11: provincial Loeschcke type I lamp.
- Plate 32.** Small finds discovered between 1971 and 1976. 1–2: wheel-made lamps; 3: bronze casting mould fragment; 4–5: crucibles; 6–7: spindle whorls. The catalogue numbers are given in brackets.
- Plate 33.** Small finds discovered between 1971 and 1976. 1: pottery counters; 2: bronze casting mould fragment; 3: pottery and stone sling-shots. The catalogue numbers are given in brackets.
- Plate 34.** Terracotta (pipeclay) figurine depicting the goddess Venus. The catalogue number is given in brackets.
- Plate 35.** The classification of the oxidized coarse (OC) fabrics.
- Plate 36.** The classification of the oxidized coarse (OC) and oxidized semifine (OS) fabrics.
- Plate 37.** The classification of the oxidized semifine (OS) and oxidized fine (OF) fabrics.
- Plate 38.** The classification of the oxidized fine (OF) and reduced coarse (RC) fabrics.
- Plate 39.** The classification of the reduced coarse (RC) and reduced semifine (RS) fabrics.
- Plate 40.** The classification of the reduced fine (RF) fabrics.

Abbreviations used in the text and the catalogues

H.	Height
Th.	Thickness
W.	Width
Lg.	Length
Dm.	Diameter
X.	Axis along the barracks' length
Y.	Axis along the barracks' width
d.	Depth
Pl.	Plate
Déch.	Déchelette 1904 (figure type codes; see bibliography)
Osw.	Oswald 1937 (figure type codes; see bibliography)
SR	Samian Research (see bibliography)
Inv. no.	Inventory number.
Mus. Zalău	County Museum of History and Art Zalău (Zilah), Sălaj County, Romania.

Bibliography

Abbreviations

Acta MN	Acta Musei Napocensis, Cluj-Napoca.
Acta MP	Acta Musei Porolissensis, Zalău.
Acta RCRF	Acta Rei Cretariae Romanae Fautorum.
AEM	Archaeologisch-Epigraphische Mittheilungen aus Oesterreich, Wien.
AJA	American Journal of Archaeology, Princeton.
AJP	American Journal of Philology, Baltimore.
ANRW	H. Temporini (ed.), Aufstieg und Niedergang der römischen Welt.
Archaeologia Bulgarica	Archaeologia Bulgarica, Sofia.
Archaeological Dialogues	Archaeological Dialogues, Cambridge.
Archeológiai Értesítő	Archeológiai Értesítő, Budapest.
AUA Ser. Hist.	Annales Universitatis Apulensis. Series Historica, Alba Iulia
BAR	British Archaeological Reports, Oxford.
Bericht RGK	Bericht der Römisch-Germanischen Kommission, Frankfurt a. M.
BMN	Bibliotheca Musei Napocensis, Cluj-Napoca.
BMP	Bibliotheca Musei Porolissensis (Zalău).
Britannia	Britannia. A journal of Romano-British and kindred studies, London.
Comptes Rendus	Comptes rendus des séances de l'Académie des Inscriptions et Belles-Lettres, Paris.
Dacia	Dacia. Recherches et découvertes archéologiques en Roumanie, București.
Dissertationes Pannonicae	Dissertationes Pannonicae ex Instituto Numismatico et Archaeologico Universitatis de Petro Pázmány nominatae Budapestinensis provenientes, Budapest.
Ephemeris Napocensis	Ephemeris Napocensis, Cluj-Napoca.
IEC	Interferențe etnice și culturale în mileniile I a. Chr.–I p. Chr. / Ethnic and cultural interferences in the 1st millennium B.C. to the 1st millennium A.D. Cluj-Napoca.
Instrumentum	Instrumentum. Bulletin du Groupe de travail européen sur l'artisanat et les productions manufacturées dans l'Antiquité, Chauvigny.
Jahrbuch RGZM	Jahrbuch des Römisch-Germanischen Zentralmuseums, Mainz.
Jahresbericht GpV	Jahresbericht Gesellschaft Pro Vindonissa, Brugg.
JRA	Journal of Roman Archaeology, Portsmouth, Rhode Island.
JRS	Journal of Roman Studies, London.
Limes	Limes, Frontierele Imperiului Roman în România, Cluj-Napoca.
Lucerna	Lucerna. Roman finds group newsletter.
Marisia	Marisia. Studii și materiale arheologie, Târgu Mureș.
Metalla	Metalla. Journal of Science and Technology, Deutsches Bergbau Museum (Bochum).
MTA Évkönyvei	A Magyar Tudományos Akadémia Évkönyvei, Budapest.

OJA	Oxford Journal of Archaeology, Oxford.
PAT	Patrimonium Archaeologicum Transylvanicum, Cluj-Napoca.
Revista Bistriței	Revista Bistriței, Bistrița.
Saalburg Jahrbuch	Saalburg Jahrbuch, Bad Homburg vor der Höhe.
SCIV	Studii și cercetări de istorie veche și arheologie, București.
Sonderschriften ÖAI	Sonderschriften des Österreichischen Archäologischen Institutes, Wien.
SAA	Studia Antiqua et Archaeologica, Iași.
SUBB Historia	Studia Universitatis Babeș-Bolyai, Historia, Cluj-Napoca.
Syria	Syria. Revue d'Art Orientale et d'Archéologie, Paris.
Tyche	Tyche. Beiträge zur Alten Geschichte, Papyrologie und Epigraphik, Wien.
Veröffentlichungen GpV	Veröffentlichungen der Gesellschaft Pro Vindonissa, Brugg.

Adams 1999

J.N. Adams, The poets of Bu Njem: language, culture and the centurionate, *JRS* 89, 1999, 109–134.

Allason-Jones 2011

L. Allason-Jones, 'Recreation'. In: L. Allason-Jones (ed.), *Artefacts in Roman Britain. Their purpose and Use*, Cambridge 2011, 219–242

Allison 1999

P.M. Allison, Labels for ladles: interpreting the material culture of Roman households. In: P.M. Allison (ed.), *The archaeology of household activities*, London and New York 1999, 57–77.

Allison 2005

P.M. Allison, Mapping artefacts and activities within Roman forts. In: *LIMES XIX*, 833–846.

Allison 2006

P.M. Allison, Mapping for gender. Interpreting artefact distribution inside 1st and 2nd-century A.D. forts in Roman Germany, *Archaeological Dialogues* 13/1, 2006, 1–20.

Allison 2007

P.M. Allison, Artefact distribution within the auxiliary fort at Ellingen: evidence for building use and for the presence of women and children, *Bericht RGK* 87, 2006, 387–452.

Allison 2013

P.M. Allison, *People and spaces in Roman military bases*, Cambridge 2013.

Alston 1995

R. Alston, *Soldier and Society in Roman Egypt. A Social History*, London and New York 1995.

Antal 2012

A. Antal, The cult of Venus within the forts from Dacia, *ActaMN* 47–48/I 2010–2011 (2012), 91–113.

Ardeț 2006

A. Ardeț, *Amforele din Dacia romană*, Timișoara 2006.

Auriemma/Quiri 2004

R. Auriemma, E. Quiri, Importazioni di anfore orientali nell'Adriatico tra primo e medio impero. In: J. Eiring, J. Lund (eds.), *Transport amphorae and trade in the Eastern Mediterranean*, Monographs of the Danish Institute at Athens 5, Athens 2004, 43–55.

Bahn 1989

P.G. Bahn, *Bluff your way into archaeology*, Horsham 1989.

Bailey 1980

D.M. Bailey, *A catalogue of the lamps in the British Museum II. Roman lamps made in Italy*, London 1980.

Bailey 1988

D.M. Bailey, *A catalogue of the lamps in the British Museum III. Roman provincial lamps*, London 1988.

Baranowski et al. 2015

M. Baranowski, M. Daszkiewicz, D. Petruț, G. Schneider, Moesian or Dacian sigillata – A provenance study by WD-XRF and P-XRF. In: T. Gluhak, S. Greiff, K. Kraus, M. Prange (Hrsg.), *Archäometrie und Denkmalpflege 2015*, Jahrestagung an der Johannes-Gutenberg-Universität, Mainz (25–28 März 2015). Metalla Sonderheft 7, 95–97.

Barrett 2006

J.C. Barrett, Agency, the duality of structure and the problem of the archaeological record. In: I. Hodder (ed.), *Archaeological theory today*, Cambridge 2006, 141–164.

Bayley/Budd 1998

J. Bayley, P. Budd, 'The clay moulds'. In: H.E.M. Cool, C. Philo (eds.), *Roman Castleford. Excavations 1974–85. Volume I. The small finds*, Wakefield 1998, 195–222.

Bejinariu et al. 2016

I. Bejinariu, H. Pop, D. Culic, E. Pripon, D. Băcuciu-Crișan, D. Deac, Buciumi, jud. Sălaj – Castrul roman. Punct: Grădiște, Cetate. In: I. Opreș, Z.K. Pinter, F. Matei-Popescu (ed.), *Cronica cercetărilor arheologice din România. Campania 2015*, Târgu-Jiu 2016, 124–125.

Bémont/Jacob 1986

C. Bémont, J.-P. Jacob (eds.), *La terre sigillée Gallo-Romaine. Lieux de production du Haut Empire: implantations, produits, relations*, Document d'archéologie française 6, Paris 1986.

Bernal Casasola 2006

D. Bernal Casasola, Alimentos béticos, cerámicas y militares en Dacia. Reflexiones y líneas de investigación. In: D. Bondoc (ed.), *In honorem Gheorghe Popilian*, Craiova 2006, 97–115.

Bezczky 1997

T. Bezczky, Amphorae from the auxiliary fort of Carnuntum. In: H. Stiglitz, *Das Auxiliarkastell Carnuntum 1*, Sonderschriften ÖAI 29, Wien 1997, 147–178.

Bezczky 1998

T. Bezczky, *The Laecanius amphora stamps and villas of Brijuni*, Österreichische Akademie der Wissenschaften, Philosophisch-Historische Klasse Denkschriften 261, Wien 1998.

Bezczky 2005

T. Bezczky, Roman amphorae from Vindobona. In: Fr. Krinzinger, *Vindobona. Beiträge zu ausgewählten Keramikgattungen in ihrem topographischen Kontext*, Österreichische Akademie der Wissenschaften, Philosophisch-Historische Klasse, Denkschriften 328, Archäologische Forschungen 12, Wien 2005, 35–83, Pl. 1–23.

Biddulph 2008

E. Biddulph, Form and Function: The Experimental Use of Roman Samian Ware Cups, *OJA* 27(1), 2008, 91–100.

Birley 1997

A.R. Birley, Supplying the Batavians at Vindolanda. In: LIMES XVI, 273–280.

Birley 2002a

A.R. Birley, *Garrison life at Vindolanda. A band of brothers*, Stroud 2002.

Birley 2002b

A.R. Birley, The Roman army in the Vindolanda tablets. In: LIMES XVIII, 925–930.

Bishop 1985

M.C. Bishop, The military *fabrica* and the production of arms in the early Principate. In: M.C. Bishop (ed.), *The Production and Distribution of Roman Military Equipment. Proceedings of the second Roman Military Equipment Research Seminar*, BAR International Series 275, 1985. Oxford 1985, 1–42.

Bishop/Coulston 2006

M.C. Bishop, J.C.N. Coulston, *Roman military equipment from the Punic Wars to the fall of Rome*, Second edition, Oxford 2006.

Bowman 1994

A.K. Bowman, *Life and letters on the Roman frontier. Vindolanda and its people*, London 1994.

Bowman/Thomas 1983 (= TV I)

A.K. Bowman, J.D. Thomas, *Vindolanda: the Latin writing-tablets*, Britannia Monograph Series 4, London 1983.

Bowman/Thomas 1994 (= TV II)

A.K. Bowman, J.D. Thomas, *The Vindolanda writing-tablets (Tabulae Vindolandenses II)*, London 1994.

Bowman/Thomas 2003 (= TV III)

A.K. Bowman, J.D. Thomas, *The Vindolanda writing-tablets (Tabulae Vindolandenses) Volume III*, London 2003.

Bowman et al. 2010 (= TV IV/1)

A.K. Bowman, J.D. Thomas, R.S.O. Tomlin, The Vindolanda writing-tablets (*Tabulae Vindolandenses IV*, Part 1), *Britannia* 41, 2010, 187–224.

Braithwaite 2007

G. Braithwaite, *Faces from the Past: A Study of Roman Face Pots from Italy and the Western Provinces of the Roman Empire*, BAR International Series 1651, Oxford 2007.

Breeze 1977

D.J. Breeze, The fort at Bearsden and the supply of Pottery to the Roman army. In: J. Dore, K. Greene (eds.), *Roman Pottery Studies in Britain and Beyond*, BAR Supplementary Series 30, Oxford 1977, 133–145.

Breeze 1993

D. J. Breeze, The organisation of the career structure of the *immunes* and *principales* of the Roman army. In: D.J. Breeze, B. Dobson (eds.), *Roman Officers and Frontiers*, Mavors Roman Army Researches 10, Stuttgart 1993, 11–58.

Breeze 2000

D.J. Breeze, Supplying the army. In: G. Alföldy, B. Dobson, W. Eck (Hrsg.), *Kaiser, Heer und Gesellschaft in der Römischen Kaiserzeit. Gedenkschrift für Eric Birley*, Heidelberger Althistorische Beiträge und Epigraphische Studien 31, Stuttgart 2000, 59–64.

Campbell 1994

B. Campbell, *The Roman army 31 BC–AD 337. A sourcebook*, London and New York 1994.

Carreras Monfort 2002

C. Carreras Monfort, The Roman military supply during the Principate. Transportation and staples. In: P. Erdkamp (ed.), *The Roman army and the economy*, Amsterdam 2002, 70–89.

Carroll 2005

M. Carroll, The preparation and consumption of food as a contributing factor towards communal identity in the Roman army. In: LIMES XIX, 363–372.

CSD

B.S. Turner (ed.), *The Cambridge dictionary of sociology*, Cambridge 2006.

Chinelli 2005

R. Chinelli, Eiförmige und birnenförmige Gefäße aus Wien. In: Fr. Krinzing, *Vindobona. Beiträge zu ausgewählten Keramikgattungen in ihrem topographischen Kontext*, Österreichische Akademie der Wissenschaften. Philosophisch-Historische Klasse, Denkschriften 328, Archäologische Forschungen 12, Wien 2005, 143–170.

Chirilă et al. 1972

E. Chirilă, N. Gudea, V. Lucăcel, C. Pop, *Das Römerlager von Buciumi. Beiträge zur Untersuchung des Limes der Dacia Porolissensis*, Cluj 1972.

Ciauşescu 2006

M. Ciauşescu, A Roman pottery assemblage from the legionary fortress at Apulum. In: D. Bondoc (ed.), *In honorem Gheorghe Popilian*, Craiova 2006, 142–162.

Ciauşescu/Mustaţă 2009

M. Ciauşescu, S. Mustaţă, Ceramica din aşezarea romană / The pottery from the Roman settlement. In: S. Mustaţă, Fl. Gogâltan, S. Cociş, A. Ursuţiu (eds.), *Cercetări arheologice preventive la Floreşti–Polus Center, jud. Cluj (2007) / Rescue Excavations at Floreşti–Polus Center, Cluj County (2007)*, PAT 1, Cluj-Napoca 2009, 243–278.

CIL III

Corpus Inscriptionum Latinarum III, Berlin 1873 (Supplementum: 1902).

Clarke 1997

S. Clarke, Abandonment, rubbish disposal and ‘special’ deposits at Newstead. In: K. Meadows, C. Lemke, J. Heron (eds.), *Proceedings of the 6th Annual Theoretical Roman Archaeology Conference, held at the University of Sheffield*, Oxford 1997, 73–81.

Clarke 2000

S. Clarke, In search of a different Roman period: The finds assemblage at the Newstead military complex. In: G. Fincham, G. Harrison, R. Holland, L. Revell (eds.), *Proceedings of the 9th Annual Theoretical Roman Archaeology Conference, held at the University of Durham*, Oxford 2000, 22–29.

Conspectus

E. Ettlinger, B. Hedinger, B. Hoffmann, Ph. Kenrick, G. Pucci, K. Roth-Rubi, G. Schneider, S. v. Schnurbein, C.M. Wells, S. Zabehlicky-Scheffenecker, *Conspectus formarum terrae sigillatae Italico modo confectae*, Materialien zur Römisch-Germanischen Keramik 10, Bonn 1990.

Cool 2006

H.E.M. Cool, *Eating and drinking in Roman Britain*, Cambridge 2006.

Coulston 2004

J.C.N. Coulston, Military identity and personal self-identity in the Roman army. In: L. De Ligt, E.A. Hemelrijk, H.W. Singor (eds.), *Roman Rule and Civic Life: Local and Regional Perspectives*, Proceedings of the fourth workshop of the international network Impact of Empire (Roman Empire, c. 200 B.C.–A.D. 476), Leiden June 25–28, 2003, Impact of Empire 4, Amsterdam 2004, 133–152.

Crnobrnja 2008

A.N. Crnobrnja, Economic aspects of the use of Roman oil lamps in Moesia Superior. In: D. Gergova, A. Bozhkova, Chr. Popov, M. Kuzmanov (eds.), *Phosphorion. Studia in honorem Mariae Čičikova*, Sofia 2008, 408–412.

Crummy 2007

N. Crummy, Six honest men: a basic methodology for the study of small finds. In: R. Hingley, S. Willis (eds.), *Roman finds: Context and Theory, Proceedings of a conference held at the University of Durham*, Oxford 2007, 59–66.

Cupșa 2009

C.G. Cupșa, *Ceramica din castrele romane de la Bologa și Cășeiu. Considerații asupra vaselor de uz casnic*, Unpublished PhD thesis, Babeș-Bolyai University, Cluj-Napoca 2009.

Dana/Petruț 2015

D. Dana, D. Petruț, A military graffito on a pottery plate from the auxiliary fort at Buciumi (Roman Dacia), *Tyche* 30, 2015, 19–24, Taf. 3–4.

Dannell 1987

G.B. Dannell, 'Coarse Pottery'. In: G.B. Dannell, J.P. Wild, *Longthorpe II. The Military Works-Depot: An Episode in Landscape History*, Britannia Monographs Series 8, London 1987, 133–167.

Daszkiewicz et al. 2018

M. Daszkiewicz, G. Schneider, M. Baranowski, D. Petruț, V. Rusu-Bolindeț, N. Man, Moesian and Dacian sigillata – exploring regional patterns (A methodological approach using chemical analysis by WD-XRF and p-ED-XRF), *Acta RCRF* 45, 2018, 541–549.

Davies 1971

R. W. Davies, The Roman military diet, *Britannia* 2, 1971, 122–142.

Davies 1974

R.W. Davies, The daily life of the Roman soldier under the Principate, *ANRW* 2/1, Tübingen 1974, 299–334.

Davison 1989

D.P. Davison, *The barracks of the Roman army from the 1st to 3rd centuries A.D. A comparative study of the barracks from fortresses, forts and fortlets with an analysis of building types and construction, stabling and garisons*, BAR International Series 472 (I–II), Oxford 1989.

Déchelette 1904 (= Déch.)

J. Déchelette, *Les vases céramiques ornés de la Gaule Romaine* I–II, Paris 1904.

Deetz 1996

J. Deetz, *In small things forgotten: An archaeology of early American life*, Revised edition, New York 1996.

Döhner et al. 2011

G. Döhner, M. Fiedler, C. Höpken, Chr. Merzenich, Sz.P. Pánczél, V. Stürmer, Zs. Vasáros, Forschungen im Kastell von Porolissum. Bericht zur Kampagne 2009, *Marisia* 30, 2011, 115–126.

v. Driel-Murray 1997

C. v. Driel-Murray, Women in forts? *Jahresbericht GpV* 1997, 55–62.

DSU

F. Gresle, M. Panoff, M. Perrin, P. Tripier, *Dicționar de științe umane: antropologie/sociologie*, (Trad. I. Negrea, M. Gabriel-Florin), București 2000.

Dunbabin 2003

K.M.D. Dunbabin, *The Roman Banquet. Images of conviviality*, 2003 Cambridge.

Dungworth/Starley 2009

D.B. Dungworth, D. Starley, 'The metalworking debris'. In: Rushworth 2009, 579–588.

Dyczek 2001

P. Dyczek, *Roman amphorae of the 1st and 3rd centuries AD found on the Lower Danube. Typology*, Warszawa 2001.

Eckardt 2002a

H. Eckardt, *Illuminating Roman Britain*, Monographies Instrumentum 23, Montagnac 2002.

Eckardt 2002b

H. Eckardt, Candlesticks in Roman Britain, *Lucerna* 24, 15–16.

Eckardt 2011

H. Eckardt, 'Heating and lighting', In: L. Allason-Jones (ed.), *Artefacts in Roman Britain. Their purpose and use*, Cambridge 2011, 180–193.

Egri 2008

M. Egri, Roman campaigns in the Danube region. The olive oil supply from Augustus to Trajan, *Ephemeris Napocensis* 18, 2008, 45–56.

Egri/Inel 2006

M. Egri, C. Inel, Inscriptions on amphorae and the military supply. In D. Bondoc (ed.), *In honorem Gheorghe Popilian*, Craiova 2006, 191–195.

EHA

Ch.E. Orser, Jr. (ed.), *Encyclopedia of historical archaeology*, London and New York 2002.

ESCA

A. Barnard, J. Spencer (eds.), *Encyclopedia of social and cultural anthropology*, London and New York 2002.

Ettlinger 1951

E. Ettlinger, Legionary Pottery from Vindonissa, *JRS* 41, 1951, 105–111.

Fiedler/Höpken 2004

M. Fiedler, C. Hopken, Wein oder Weihrauch – "Turibula" aus Apulum. In: L. Ruscu, C. Ciongradi, R. Ardevan, C. Roman, C. Găzdac (eds.), *Orbis antiquus. Studia in honorem Ioannis Pisonis*, BMN 21, Cluj-Napoca, 510–516.

Filip 2008

C.C. Filip, *Ceramica ștampilată de la Porolissum*, Porolissum. Un complex arheologic daco-roman la marginea de nord a Imperiului Roman 5, Cluj-Napoca 2008.

Fink 1942

R.O. Fink, Mommsen's Pridianum: BGU, 696, *AJPh* 63/1, 1942, 61–71.

Fink 1958

R.O. Fink, Hunt's Pridianum: British Museum Papyrus 2851, *JRA* 48, 1/2, 1958, 102–116.

Fink 1971 (= RMR)

R.O. Fink, *Roman military records on papyrus*, Philological Monographs of the American Philological Association 26, Cleveland 1971.

Fink et al. 1940

R.O. Fink, A.S. Hoey, W.F. Snyder, *The Feriale Duranum*, Yale Classical Studies 7, New Haven 1940.

Fischwick 1988

D. Fishwick, Dated inscriptions and the Feriale Duranum, *Syria* 65/3–4, 1988, 349–361.

Freeman 1996

P.W.M. Freeman, Roman frontier studies: what's new? *Britannia* 27, 1996, 465–470.

Fulford 2010

M. Fulford, Roman Britain: immigration and material culture. In: H. Eckardt (ed.), *Roman diasporas. Archaeological approaches to mobility and diversity in the Roman Empire*, JRA Supplementary Series 78, Portsmouth, Rhode Island 2010, 67–78.

Freeman 2007

P.W.M. Freeman, *The best training-ground for archaeologists. Francis Haverfield and the invention of Romano-British archaeology*, Oxford 2007.

Gabler 2006

D. Gabler, *Terra Sigillata, a rómaiak luxuskerámiaja*, Museion sorozat 6, Budapest 2006.

Gamble 2001

C. Gamble, *Archaeology: the basics*, London and New York 2001.

Gardner 2007a

A. Gardner, *An archaeology of identity. Soldiers and society in late Roman Britain*, 2007.

Gardner 2007b

A. Gardner, Artefacts, Contexts and the Archaeology of Social practices. In: R. Hingley, S. Willis (eds.), *Roman finds: Context and Theory, Proceedings of a conference held at the University of Durham*, Oxford 2007, 129–139.

Gassner/Jilek 1997

V. Gassner, S. Jilek, Zum Problem der 'Legionswäre' und ihrer Verbreitung von Germanien bis Moesien. In: *LIMES XVI*, 301–309.

Găzdac/Pripon 2012

C. Găzdac, E. Pripon, *The Roman fort at Buciumi (Roman Dacia, Romania). Coins in Archaeological context*, BAR International Series 2381, Oxford 2012.

Giles 2012

R.D. Giles, *Roman soldiers and the Roman army. A study of military life from archaeological remains*, BAR British Series 562, Oxford 2012.

Gilliam 1986

J.F. Gilliam, The Moesian "Pridianum". In: J.F. Gilliam, *Roman Army Papers*, Amsterdam 1986, 263–272.

Greene 1977

K. Greene, Legionary pottery and the significance of Holt. In: J. Dore, K. Greene (eds.), *Roman pottery studies in Britain and beyond*, BAR Supplementary Series 30, Oxford 1977, 113–132.

Greep 1987

S.J. Greep, Lead slingshots from Windridge Farm, St. Albans and the use of the sling by the Roman army in Britain, *Britannia* 18, 1987, 183–200.

Griffiths 1989

W.B. Griffiths, The sling and its place in the Roman Imperial army. In: C. van Driel-Murray (ed.) *Roman Military Equipment: The sources of Evidence. Proceedings of the Fifth Roman Military Equipment Conference*, BAR International Series 476, Oxford 1989, 255–279.

Griffiths 2009

W.B. Griffiths, 'Stone missiles'. In: Rushworth 2009, 482.

Grünewald 1986

M. Grünewald, *Keramik und Kleinfunde des Legionslagers von Carnuntum*, Der römische Limes in Österreich 34, Wien 1986.

Gudea 1970

N. Gudea, Ceramica dacică din castrul roman de la Buciumi (jud. Sălaj), *SCIV* 21/2, 1970, 299–311.

Gudea 1982

N. Gudea, Despre câteva donaria și aplici de disc cu inscripție din Dacia, *Acta MP* 6, 1982, 51–57.

Gudea 1984

N. Gudea, Din nou despre câteva fragmente de diplome militare romane și plăcuțe de bronz cu inscripție din Dacia Porolissensis, *Acta MP* 8, 211–218.

Gudea 1995

N. Gudea, Über die Produktion von glasierten Gefäßen in den dakischen Provinzen, *Acta RCRF* 34, 1995, 115–120.

Gudea 1997a

N. Gudea, Der Dakische Limes. Materialien zu seiner Geschichte, *Jahrbuch RGZM* 44, 1997, 1–113.

Gudea 1997b

N. Gudea, *Castrul roman de la Buciumi / Das Römergrenzkastell von Buciumi*, Ghid al monumentelor arheologice din Dacia Porolissensis / Führer zu archäologischen Denkmäler aus Dacia Porolissensis 2, Zalău 1997.

Gudea 1997c

N. Gudea, *Castrul roman de pe dealul Pomiet-Moigrad / Das Römergrenzkastell von Moigrad-Pomet. Porolissum I*, Ghid al monumentelor arheologice din Dacia Porolissensis / Führer zu archäologischen Denkmäler aus Dacia Porolissensis 5, Zalău 1997.

Gudea 2000

N. Gudea, Dacia Porolissensis. I. Contribuții la o bibliografie a istoriei militare și la un scurt istoric al cercetărilor, *Revista Bistriței* 14, 2000, 355–78.

Gudea 2005

N. Gudea, Despre consumuri ale armatei romane din Dacia Porolissensis. Necesități, producție locală și importuri – Studiu preliminar. In: C. Cosma, A. Rustoiu (ed.), *Comerț și civilizație. Transilvania în contextul schimburilor comerciale și culturale în antichitate*, IEC 7, Cluj-Napoca 2005, 211–268.

Gudea 2009

Al. Gudea, *Soldatul roman în Dacia (106–275 p. Chr.)*. Studiu arheozoologic privind creșterea animalelor și regimul alimentar în armata romană, IEC 15, Cluj-Napoca 2009.

Gudea/Bajusz 1991

N. Gudea, I. Bajusz, Ace de păr din os de la Porolissum. Câteva observații în legătură cu acele de păr din os din provinciile dacice, *Acta MP* 14–5, 1990–1991, 81–126.

Gudea/Bajusz 1992

N. Gudea, I. Bajusz, Instrumente medicale și ustensile folosite de medicii și farmaciștii romani din Dacia Porolissensis. Contribuții la studiul medicinei romane, *Acta MP* 16, 1992, 249–291.

Gudea/Cociș 1995

Gudea, S. Cociș, Fibule romane din castrul de la Buciumi și Bologa (Dacia Porolissensis), *Acta MP* 19, 1995, 49–59.

Gudea/Cosma 2003

N. Gudea, C. Cosma, Opaitele din castrul roman de la Buciumi (Dacia Porolissensis). In: C. Firea (ed.), *Artă, istorie, cultură: studii în onoarea lui Marius Porumb*, Cluj-Napoca 2003, 21–38.

Gudea/Cosma 2008

N. Gudea, C. Cosma, Die Lampen aus dem Römerkastell von Buciumi (Dacia Porolissensis). In: C. A. Roman, N. Gudea (eds.), *Lychnological Acts 2. Trade and local production of lamps from the prehistory until the Middle Age*, PAT 2, Cluj-Napoca 2008, 117–128, Pl. 85–97.

Gudea/Landes 1981

N. Gudea, A. Landes, Propuneri pentru o reconstituire grafică a castrului roman de la Buciumi III. Barăcile, *Acta MP*, 1981, 247–271.

Gudea/Matei 1981

N. Gudea, A. V. Matei, Chei romane în Muzeul de Istorie și Artă din Zalău, *Acta MP* 5, 1981, 191–223.

Gui 2011

M. Gui, Evidence for medical and personal care in the case of the Roman army in Dacia, *Ephemeris Napocensis* 21, 2011, 115–130.

Gui 2012

M. Gui, Small finds – What are they good for? *AUA Ser. Hist.* 16/1, 2012, 37–45.

Gui/Petruț 2018

M. Gui, D. Petruț, Soldiers and their monuments for posterity. Manifestations of martial identity in the funerary iconography of Roman Dacia. In: G. Cupcea, R. Varga (eds.), *Social interactions and status markers in the Roman World*, Archaeopress Roman Archaeology 37, Oxford 2018, 115–138.

Haalebos 1992

J. K. Haalebos, Italische Töpfer in Nijmegen (Niederlande)? *Acta RCRF* 31/32, 1992, 365–382.

Harris 1980

W.V. Harris, Roman terracotta lamps: the organization of an industry, *JRS* 70, 1980, 126–145.

Harsányi 2006

E., Harsányi, A füstölők és a füstölés szokása a császárkorban, *Antik Tanulmányok* 50, 2006, 57–73.

Hartley 2007

B.R. Hartley, 'Samian ware'. In: W.S. Hanson, *Elginhaugh: A Flavian Fort And Its Annexe*, vol. 1–2, Britannia Monograph Series 23, London 2007, 379–395.

Hawthorne 1998

J.W.J. Hawthorne, Pottery and paradigm in the early Western Empire. In: C. Forcey, J. Hawthorne, R. Witcher (eds.), *TRAC 97, Proceedings of the 7th annual Theoretical Roman Archaeology Conference, University of Nottingham*, Oxford 1998, 160–172.

Hayes 1997

J.W. Hayes, *Handbook of Mediterranean Roman Pottery*, London 1997.

Haynes 1999a

I. Haynes, Introduction. In: A. Goldsworthy, I. Haynes (eds.), *The Roman Army as a Community*, JRA Supplementary Series 34, Portsmouth, Rhode Island 1999, 7–14.

Haynes 1999b

I. Haynes, Military service and cultural identity in the *auxilia*. In: A. Goldsworthy, I. Haynes (eds.), *The Roman Army as a Community*, JRA Supplementary Series 34, Portsmouth, Rhode Island 1999, 165–174.

Herz 2002

P. Herz, Die Logistik der Kaiserzeitlichen Armee. Strukturelle Überlegungen. In: P. Erdkamp (ed.), *The Roman army and the economy*, Amsterdam 2002, 19–46.

Higgins 1976

R. Higgins, 'Terracottas'. In: D. Strong, D. Brown (eds.), *Roman Crafts*, London 1976, 105–109.

Hilgers 1969

W. Hilgers, *Lateinische Gefäßnamen. Bezeichnungen, Funktion und Form römische Gefäße nach den antiken Schriftquellen*, Beihefte der Bonner Jahrbuch 31, Düsseldorf 1969.

Hodgson 2002

N. Hodgson, 'Where did they put the horses?' revisited: the recent discovery of cavalry barracks in the Roman forts at Wallsend and South Shields on Hadrian's Wall. In: *LIMES XVIII*, 887–894.

Hodgson 2003

N. Hodgson, *The Roman Fort at Wallsend (Segedunum). Excavations in 1997-98*, Tyne and Wear Museums Archaeological Monograph 2, Newcastle upon Tyne 2003.

Hodgson/Bidwell 2004

N. Hodgson, P.T. Bidwell, Barracks in a new light: Recent discoveries on Hadrian's Wall, *Britannia* 35, 2004, 121–157.

Hoffmann 1995

B. Hoffmann, The quarters of legionary centurions of the Principate, *Britannia* 26, 1995, 107–151.

Hope 1997

V.M. Hope, Words and pictures: the interpretation of Romano-British tombstones, *Britannia* 28, 245–258.

Hope 2001

V.M. Hope, *Constructing identity: the Roman funerary monuments of Aquileia, Mainz and Nimes*, BAR International Series 960, Oxford 2001.

Hüsen 1992

C.M. Hüsen, Grabungen und Forschungen der letzten 40 Jahre im obergermanischen und rätischen Limesgebiet. In: *Der römische Limes in Deutschland: 100 Jahre Reichs-Limeskommission*, Stuttgart 1992, 33–70.

IDR Appendix I

I. Piso, D. Deac, *Inscriptiones Daciae Romanae. Appendix I: Inscriptiones laterum Musei Zilahensis*, Cluj-Napoca 2016.

Ionescu/Ghergari 2007

C. Ionescu, L. Ghergari, Caracteristici mineralogice si petrografice ale ceramicii romane din Napoca. In: *Rusu-Bolindeț 2007*, 434–462.

Isaac 1992

B. Isaac, *The limits of Empire. The Roman army in the East*, Revised version, Oxford 1992.

Isac 1977

D. Isac, Terra sigillata din castrul roman de la Buciumi, *Acta MP* 1, 1977, 155–172.

Isac 2006

D. Isac, Archaeological interpretations: the relationship between artefacts and the functionality of some of the buildings within the forts (*spatha* and the spurs from a *stabulum* of the fort from Samvm-Cășeu). In: C. Gaiu, C. Găzdac (eds.) *Fontes Historiae. Studia in honorem Demetrii Protase*, Cluj-Napoca 2006, 437–453.

Isac et al. 1994

D. Isac, P. Hügel, D. Andreica, Praetoria in dakischen Militäranlagen, *Saalburg Jahrbuch* 47, 1994, 40–64.

Istenič 1999

J. Istenič, *Poetovio, zahodna grobišča I: grobne celote iz Deželnega muzeja Joanneuma v Gradcu*, Katalogi in Monografije 32, Ljubljana 1999.

Iványi 1935

D. Iványi, *Die pannonischen Lampen. Eine typologisch-chronologische Übersicht*, Dissertationes Pannonicae 2.2, Budapest 1935.

James 1999

S. James, The community of the soldiers: a major identity and centre of power in the Roman empire. In: P. Baker, C. Forcey, S. Jundi, R. Witcher (eds.), *TRAC 98, Proceedings of the eight Annual Theoretical Roman Archaeology Conference, University of Leicester, April 1998*, Oxford 1999, 14–25.

James 2004

S. James, *The Excavations at Dura-Europos conducted by Yale University and the French Academy of Inscriptions and Letters 1928 to 1937. Final Report VII. The arms and armour and other military equipment*, London 2004.

Johnson 1983

A. Johnson, *Roman forts of the 1st and 2nd centuries AD in Britain and the German provinces*, London 1983.

Josephus, JW

Josephus Flavius, *The Jewish War, Books I–III*, Translated by H. St. J. Thackeray, Loeb Classical Library, London – Cambridge, Massachusetts 1927.

Junkelmann 1997

M. Junkelmann, *Panis militaris. Der Ernährung des römischen Soldaten oder Grundstoff der Macht*, Mainz 1997.

Jurišić 2000

M. Jurišić, *Ancient shipwrecks of the Adriatic: maritime transport during the first and second centuries AD*, BAR International Series 828, Oxford 2000.

Kiernan 2009

Ph. Kiernan, *Miniature votive offerings in the North-Western Provinces of the Roman Empire*, Mainz 2009.

Lander 1984

J. Lander, *Roman stone fortifications. Variation and change from the first century A.D. to the fourth*, BAR International Series 206, 1984, Oxford 1984.

Landes 1979

A. Landes, Propuneri pentru o reconstituire a castrului roman de la Buciumi (I) Sistemul defensiv, *Acta MP* 3, 1979, 411–426.

Landes/Gudea 1980

A. Landes, N. Gudea, Propuneri pentru o reconstituire grafică a castrului roman de la Buciumi (II). Clădirea comandamentului, *Acta MP* 4, 1980, 211–227.

Landes-Gyémánt/Gudea 1984

A. Landes-Gyémánt, N. Gudea, Castrul roman de la Buciumi, propuneri pentru o reconstituire grafică, I–IV, *Acta MP* 8, 1984, 165–210.

LIMES XVI

W. Groenman-v. Waateringe, B.L. v. Beek, W.J.H. Willems, S.L. Wynia (eds.), *Limes XVI. Proceedings of the XVIth International Congress of Roman Frontier Studies 1995*, Oxbow Monograph 91, Oxford 1997.

Limes XVIII

Ph. Freeman, J. Benett, Z.T. Fiema, B. Hoffmann (eds.), *Limes XVIII. Proceedings of the 18th International Congress of Roman Frontier Studies held in Amman, Jordan (September 2000)*, BAR International Series 1084 (I–II), Oxford 2002.

LIMES XIX

Zs. Visy (ed.), *Limes XIX. Proceedings of the XIXth International Congress of Roman Frontier Studies held in Pécs, Hungary, September 2003*, Pécs 2005.

Limes XXII

L. Vagalinski, N. Sharankov (eds.), *Limes XXII. Proceedings of the 22nd International Congress of Roman Frontier Studies, Ruse, Bulgaria, September 2012*, Bulletin of the National Archaeological Institute 42, Sofia 2015.

Luttwak 1979

E. N. Luttwak, *The grand strategy of the Roman Empire. From the first century A.D. to the third*, 2nd edition, Baltimore and London 1979.

Macmullen 1960

R. Macmullen, Inscriptions on armour and the supply of arms in the Roman Empire, *AJA* 64/1, 1960, 23–40.

Macrea et al. 1969

M. Macrea, E. Chirilă, N. Gudea, V. Lucăcel, C. Pop, Castrul roman de la Buciumi, *Acta MN* 1969, 149–157

Manning 1975

W.H. Manning, Roman military timber granaries in Britain, *Saalburg Jahrbuch* 32, 1975, 105–129.

Marcu 2004

F. Marcu, Military tile-stamps as a guide for the garrisons of certain forts in Dacia. In: L. Ruscu, C. Ciongradi, R. Ardevan, C. Roman, C. Găzdac (eds.), *Orbis Antiquus. Studia in honorem Ioannis Pisonis*, BMN 21, Cluj-Napoca 2004, 570–594.

Marcu 2009

F. Marcu, *The internal planning of Roman forts of Dacia*, BMN 30, Cluj-Napoca 2009.

Marcu 2016

F. Marcu, Frontierele Imperiului Roman în România, *Limes* 1, 2016, 4–10.

Marichal 1979

R. Marichal, Les ostraca de Bu Njem, *Comptes Rendus* 123/3, 1979, 436–452.

Marichal 1992

R. Marichal, *Le ostraca de Bu Njem*, Tripoli 1992.

Martin 2010

A. Martin, Observations on Italian sigillata: Ephesos, *Acta RCRF* 41, 2010, 17–21.

Maxfield 2003

V.A. Maxfield, Ostraca and the Roman army in the eastern desert. In: J.J. Wilkes (ed.), *Documenting the Roman army. Essays in honour of Margaret Roxan*, London 2003, 153–174.

Meyer-Freuler 2005

Chr. Meyer-Freuler, Essen und Trinken in Vindonissa im Spiegel der Keramik in der Vorlagerzeit und frühe Lagerzeit. In: *LIMES XIX*, 381–390.

Meyer-Freuler 2013

Chr. Meyer-Freuler, Keramik. In: J. Trumm, M. Flück (Hrsg.), *Am Südtor von Vindonissa Die Steinbauten der Grabung Windisch-Spillmannwiese 2003–2006 (V.003.1) im Süden des Legionslagers*, Veröffentlichungen GpV 22, 2013 Brugg, 340–381.

Meylan-Krause 2002

M.F. Meylan-Krause, La céramique culinaire d'Aventicum. Influences romaines, traditions celtiques et innovations gallo-romaine, *Bulletin de l'Association Pro Aventico* 44, 2002, 121–136.

Mihăilescu-Bîrliba 1996

V. Mihăilescu-Bîrliba, Turibula: concerning the origin and the utilization of a pottery category from the Lower Danube, *Acta RCRF* 33, 97–102.

Mustață 2011

S. Mustață, Remarks on the use and misuse of Latin terms in the study of Roman bronze vessels. In: C. Cosma (ed.), *Studii de arheologie și istorie. Omagiu profesorului Nicolae Gudea la 70 de ani / Studies in Archaeology and History. An anniversary volume to professor Nicolae Gudea on his 70th birthday*, IEC 20, Cluj-Napoca 2011, 233–239.

Mustață 2017

S. Mustață, *The Roman metal vessels from Dacia Porolissensis*, PAT 12, Cluj-Napoca 2017.

Mustață et al. 2014

S. Mustață, Sz.-P. Pánczel, D. Petruț, K. Sidó, Drinking and gaming in the Roman fort of Porolissum. Preliminary data offered by the excavation at building C3, *SUBB Historia* 59.1, 2014 ('*Banquets of gods, banquets of men. Conviviality in the ancient world*'. *Proceedings of the 16th International Conference of the Department of Ancient History and Archaeology, November 23rd–24th 2012, Cluj-Napoca, Romania*), 215–238.

Negru 1996

M. Negru, Some aspects of the lamps discovered in the Roman forts of Muntenia, *Acta RCRF* 33, 75–80.

Negru 2003

M. Negru, *The native pottery of Roman Dacia*, BAR International Series 1097, Oxford 2003.

Nemeti 2014

S. Nemeti, *Finding Arcobadara. Essay on the geography and administration of Roman Dacia*, Cluj-Napoca 2014.

Nemeti et al. 2017

S. Nemeti, I. Nemeti, (eds.), M. Andone-Rotaru, D. Bindea, D. Blaga, I. Fábíán, Fl.-Gh. Fodorean, M. Munteanu, L. Nedelea, *Studii asupra granițelor romane din Dacia. Castrul legionar de la Potaișa. I. Centuriae din praetentura sinistra*, Comisia Națională Limes, Studii și cercetări asupra frontierelor Imperiului Roman de pe teritoriul României, vol. 2, Cluj-Napoca.

Nicoară 2002

T. Nicoară, *Clio în orizontul mileniului trei: explorări în istoriografia contemporană*, Cluj-Napoca 2002.

Niculescu 2002

Gh. Al. Niculescu, Nationalism and the representation of society in Romanian archaeology. In: *Nation and national ideology past, present and prospects*, Proceedings of the International Symposium held at the New Europe College, Bucharest April 6–7, 2001, Bucharest 2002, 209–234.

NOTS

B.R. Hartley, B.M. Dickinson, *Names on terra sigillata – an index of makers' stamps and signatures on Gallo-Roman terra sigillata (samian ware)*, vol. 1–9, London 2008.

Nuber 1973

H.U. Nuber, *Kanne und Griffschale. Ihr Gebrauch im täglichen Leben und die Beigabe in Gräbern der römischen Kaiserzeit*, Bericht RGK 53, 1972 (1973).

Olcese 2003

G. Olcese, *Ceramiche comuni a Roma e in area romana: produzione, circolazione e tecnologia (Tarda età repubblicana – prima età imperiale)*, Documenti di Archeologia 28, Mantova 2003.

Oldenstein 1977

J. Oldenstein, Zur Ausrüstung römischer Auxiliareinheiten. Studien zu Beschlägen und Zierat an der Ausrüstung der römischen Auxiliareinheiten der obergermanisch-raetischen Limesgebietes aus dem zweiten und dritten Jahrhundert n.Chr., *Bericht RGK* 57, 1976, Mainz 1977, 49–284.

Opaïț 1996

A. Opaïț, *Aspecte ale vieții economice din provincia Scythia (secolele IV–VI p. Ch.). Producția ceramicii locale și de import*, Bibliotheca Thracologica 16, București 1996.

Opaiț 2004

A. Opaiț, *Local and imported ceramics in the Roman Province of Scythia (4th–6th centuries AD). Aspects of Economic Life in the Province of Scythia*, BAR International Series 1274, Oxford 2004.

Opreanu/Lăzărescu 2016

C. Opreanu, V. A. Lăzărescu (eds.), *Landscape archaeology on the northern frontier of the Roman Empire at Porolissum. An interdisciplinary research project*, Porolissum Monographs 2, Cluj-Napoca 2016.

Popa/Ó Ríagáin 2012

C.N. Popa, R. Ó Ríagáin, Archaeology and nationalism in Europe: two case studies from the northwest and southeast of Europe. In: R. Ó Ríagáin, C.N. Popa (eds.), *Archaeology and the (de)construction of national and supra-national polities*, Archaeological Review from Cambridge 27/2, Cambridge 2012, 51–70.

Orton et al. 1993

C. Orton, P. Tyers, A. Vince, *Pottery in Archaeology*, Cambridge Manuals in Archaeology, Cambridge 1993.

Oswald 1937 (= Osw.)

F. Oswald, *Index of figure-types on terra sigillata ('samian ware')*, Liverpool 1937.

Paki/Cociș 1993

A. Paki, S. Cociș, Dacia ludens, *Ephemeris Napocensis* 3, 1993, 149–161.

Pánczél 2015

Sz.-P. Pánczél, The Roman fort from Călugăreni (Mureș County, Romania). In: LIMES XXII, 909–916.

Pánczél et al. 2012

Sz.-P. Pánczél, L. Lenkey, M. Pethe, N. Laczkó, Updating our knowledge about the Roman fort from Brâncovenești, Mureș County, *Marisia* 32, 2012, 105–116.

Peacock 1977a

D.P.S. Peacock, Ceramics in Roman and Medieval Archaeology. In: D.P.S. Peacock (ed.), *Pottery in early commerce: characterization and trade in Roman and later ceramics*, London 1977, 21–34.

Peacock 1977b

D.P.S. Peacock, Pompeian Red Ware. In: D.P.S. Peacock (ed.), *Pottery in early commerce: characterization and trade in Roman and later ceramics*, London 1977, 147–162.

Peacock 1982

D.P.S. Peacock, *Pottery in the Roman World: an ethnoarchaeological approach*, Longman Archaeology Series, London and New York 1982.

Peacock/Williams 1986

D.P.S. Peacock, D.F. Williams, *Amphorae and the Roman economy: an introductory guide*, London 1986.

Pearce 2002

J. Pearce, Food as substance and symbol in the Roman army: a case study from Vindolanda. In: LIMES XVIII, 931–944.

Peña 1990

J.Th. Peña, Internal red-slip cookware (Pompeian Red Ware) from Cetamura del Chianti, Italy: mineralogical composition and provenience, *AJA* 94, 1990, 647–661.

Peña 2007

J.Th. Peña, *Roman Pottery in the archaeological record*, Cambridge 2007.

Petculescu 1987

L. Petculescu, Roman Military Granaries in Dacia, *Saalburg Jahrbuch* 43, 1987, 66–76.

v. Petrikovits 1975

H. v. Petrikovits *Die Innenbauten römischer Legionslager während der Prinzipatzeit*, Düsseldorf 1975.

Petrovsky 1993

R. Petrovsky, *Studien zu römischen Bronzegefäßen mit Meisterstempeln*, Kölner Studien zur Archäologie der Römischen Provinzen 1, Buch am Erlbach 1993.

Petruţ 2012

D. Petruţ, Everyday life in military context. Aspects of everyday life in the research concerning the Roman army in the Western European part of the Empire and the province of Dacia, *Ephemeris Napocensis* 22, 2012, 91–112.

Petruţ 2013

D. Petruţ, *Habitat și viață cotidiană în castrul auxiliar de la Buciumi (jud. Sălaj) în lumina cercetărilor arheologice*, PhD Thesis, Babeş-Bolyai University, Cluj-Napoca 2013.

Petruţ 2014

D. Petruţ, A Central Gaulish terra sigillata bowl with multiple production marks from a fort barrack in Roman Dacia, *Instrumentum* 39, 16–19.

Petruţ 2015

D. Petruţ, Aspects of military cult practice in Roman Dacia. The case of a possible miniature votive offering from the fort at Buciumi in Dacia Porolissensis. In: N. C. Rîșcuța, I. V. Ferencz, O. Tutilă Bărbat (eds.), *Representations, Signs and Symbols. Proceedings of the Symposium on Religion and Magic*, Deva. 2015, 337–344.

Petruţ 2016

D. Petruţ, The implications of indirect evidence regarding the military pottery production in Buciumi (Dacia Porolissensis) and the question of 'legionary ware', *Acta RCRF* 44 (Congressus Coloniae Ulpiae Traianae), 2016, 643–649.

Petruţ et al. 2014

D. Petruţ, M. Gui, H. Trincă, Lighting Roman military barracks. An interdisciplinary approach based on evidence from Dacia, *Archaeologia Bulgarica* 18/3, 2014, 65–92.

Piso 2015

I. Piso, Studia Porolissensia (VI), *Acta MP* 37, 2015, 193–213.

Popa et al. 2010a

Al. Popa, V. Lăzărescu, A. Dobos, R. Zăgreanu, Vorläufige Ergebnisse der Phosphatkartierung im römischen Kastell von Brețcu, *Revista Bistriței* 23, 2009, 69–74.

Popa et al. 2010b

Al. Popa, S. Cociș, Chr. Klein, C. Gaiu, N. Man, Geophysikalische Prospektionen in Ostsevenbürgen. Ein Deutsch-Rumänisch-Moldauisches Forschungsprojekt an der Ostgrenze der Römischen Provinz Dacia, *Ephemeris Napocensis* 20, 2010, 101–128.

Ricci 1985

A. Ricci, Ceramica a pareti sottili. In: *Atlante delle forme ceramiche II: ceramica fine romana nel bacino Mediterraneo (tardo ellenismo e primo impero)*, Enciclopedia dell'arte antica classica e orientale, Roma 1985, 231–357.

Rice 1987

P.M. Rice, *Pottery analysis. A sourcebook*, Chicago and London 1987.

Richmond 1962

I. Richmond, The Roman Siege-Works of Masada, Israel, *JRS* 52.1–2, 1962, 142–155.

RMR = Fink 1971

Roman 2000

C.A. Roman, Wheelmade lamps of Roman Dacia, *Acta MN* 37/1, 2000, 99–140.

Roman 2006

C.A. Roman, *Lamps from Dacia Porolissensis I. The Roman Forts from Porolissum-Moigrad, Buciumi, Gilău, Samum-Căței / Lămpi din Dacia Porolissensis I. Castele Porolissum-Moigrad, Buciumi, Gilău, Samum-Căței*, BMP 7, Zalău 2008.

Roth 1999

J.P. Roth, *The logistics of the Roman army at war (264 B.C.–235 A.D.)*, Leiden 1999.

RSV = Speidel 1996

Rushworth 2009

A. Rushworth, *Housesteads Roman Fort – The Grandest Station. Excavation and survey at Housesteads, 1954–95, by Charles Daniels, John Gillam, James Crow and others*, English Heritage Archaeological Reports, London 2009.

Russu 1959

I. I. Russu, Castrul și garnizoana de la Buciumi, *SCIV* 10/2, 1959, 305–320.

Rusu 1997

V. Rusu, Griffe keramischer Paterae aus dem römischen Dakien, *Acta MN* 34/1, 1997, 325–388.

Rusu-Bolindeț 2007

V. Rusu-Bolindeț, *Ceramica romană de la Napoca. Contribuții la studiul ceramicii din Dacia romană*, BMN 25, Cluj-Napoca 2007.

Samian Research (= SR)

<https://www1.rgzm.de/samian/home/frames.htm> (2017.09.04).

Shirley 2001

E. Shirley, *Building a Roman legionary fortress*, Stroud 2001.

Sommer 1995

C.S. Sommer, “Where did they put the horses?” Überlegungen zu Aufbau und Stärke römischer Auxiliartroppen und deren Unterbringung in den Kastellen. In: W. Czysz, C.M. Hüssen, H.P. Kuhnen, C.S. Sommer, G. Weber (Hrsg.), *Provinzialrömische Forschungen. Festschrift für Günter Ulbert zum 65. Geburtstag*, Espelkamp 1995.

Spaul 2000

J. Spaul, *Cohors. The evidence for and a short history of the auxiliary infantry units of the Imperial Roman Army*, BAR International Series 841, Oxford 2000.

Speidel 1996 (= RSV)

M.A. Speidel, *Die römischen Schreibtafeln von Vindonissa*, Veröffentlichungen GpV 12, Brugg 1996.

Speidel 1998

M.A. Speidel, Frauen und Kindern beim römischen Heer, *Gesellschaft Pro Vindonissa* Jahresbericht 1997, 53–54.

Stanciu 1985

I. Stanciu, Considerații asupra clădirii comandamentului (principia) castrelor auxiliare din Dacia, *Acta MP* 9, 1985, 219–246.

Stanfield/Simpson 1958

J.A. Stanfield, G. Simpson, *Central Gaulish potters*, London 1958.

Ștefan 1948

Gh. Ștefan, Le camp romain de Drajna de Sus, *Dacia* 11–12, 1945–47, 115–144.

Swan 1997

V.G. Swan, Vexillations and the garrisons of Britannia in the second and early third centuries: a ceramic viewpoint. In: *LIMES XVI*, 289–294.

Swan 2004

V.G. Swan, The historical significance of “Legionary Wares” in Britain. In: F. Vermeulen, K. Sas, W. Dhaeze (eds.), *Archaeology in confrontation. Aspects of Roman military presence in the Northwest. Studies in honour of Professor Em. Hugo Thoen*, Archaeological Reports Ghent University 2, Ghent 2004, 259–286.

Swan 2009

V.G. Swan, *Ethnicity, conquest and recruitment: two case studies from the northern military provinces*, JRA Supplementary Series 72, Portsmouth, Rhode Island 2009.

Timoc/Bejinariu 2000

C. Timoc, I. Bejinariu, Cercetări arheologice în principia castrului roman de la Buciumi, *Acta MP* 2000 23/1, 345–357.

Torma 1863

K. Torma, Adalék észak-nyugoti Dacia föld- és helyiratához, *MTA Évkönyvei* 12, 2, 1863, 1–39.

Torma 1879

K. Torma, Neue Inschriften aus Dacien, *AEM* 3, 86–122.

Torma 1880

K. Torma, *A Limes Dacicus felső része*, Budapest 1880.

Trigger 1989

Br. Trigger, *A History of Archaeological Thought*, Cambridge 1989.

TV I = Bowman/Thomas 1983

TV II = Bowman/Thomas 1994

TV III = Bowman/Thomas 2003

TV IV/1 = Bowman et al. 2010

Tyers 1996

P. A. Tyers, *Roman Pottery in Britain*, London 1996.

Varga 2016

R. Varga, Notes on the funerary epigraphy of soldiers from Roman Dacia, *SAA* 22/1, 2016, 77–82.

Vámos 2002

P. Vámos, Fazekasműhely az aquincumi canabae déli részén, *Archeológiai Értesítő* 127, 2002, 5–87.

Vass 2010

L. Vass, Women in a man's world? Female related artefacts from the camps of Dacia, *Marisia* 30, 2010, 127–152.

Watson 1969

G.R. Watson, *The Roman soldier*, London 1969.

Watson 1974

G. Watson, Documentation in the Roman army, *ANRW* 2/1, 493–507.

Webster 1976

Gr. Webster, *Romano-British coarse pottery: a student's guide*, Third edition, Council for British Archaeology Research Report 6, London 1976.

Whittaker 2002

C.R. Whittaker, Supplying the army. Evidence from Vindolanda. In: P. Erdkamp (ed.) *The Roman army and the economy*, Amsterdam 2002, 204–234.

Whittaker 2004

C.R. Whittaker, *Rome and its frontiers: the dynamics of Empire*, London and New York 2004.

Williams 1979

D.F. Williams, Ceramic petrology and the archaeologist. In: M. Millett (ed.), *Pottery and the Archaeologist*, Institute of Archaeology Occasional Publications 4, London 1979, 73–76.

Williams 1994

D.F. Williams, 'The amphorae'. In: P. Bidwell, S. Speak, *Excavations at South Shields Roman Fort*. Vol. 1, Monograph Series 4, Newcastle 1994, 214–219.

Wilmott 1997

T. Wilmott, A new building type in an auxiliary fort: the Birdoswald basilica and its discovery. In: *LIMES* XVI, 581–586.

Zăgreanu/Pop 2015

R. Zăgreanu, H. Pop, New sculptural monuments found in the Roman fort from Buciumi, *Revista Bistriței* 29, 2015, 123–127.

Plates

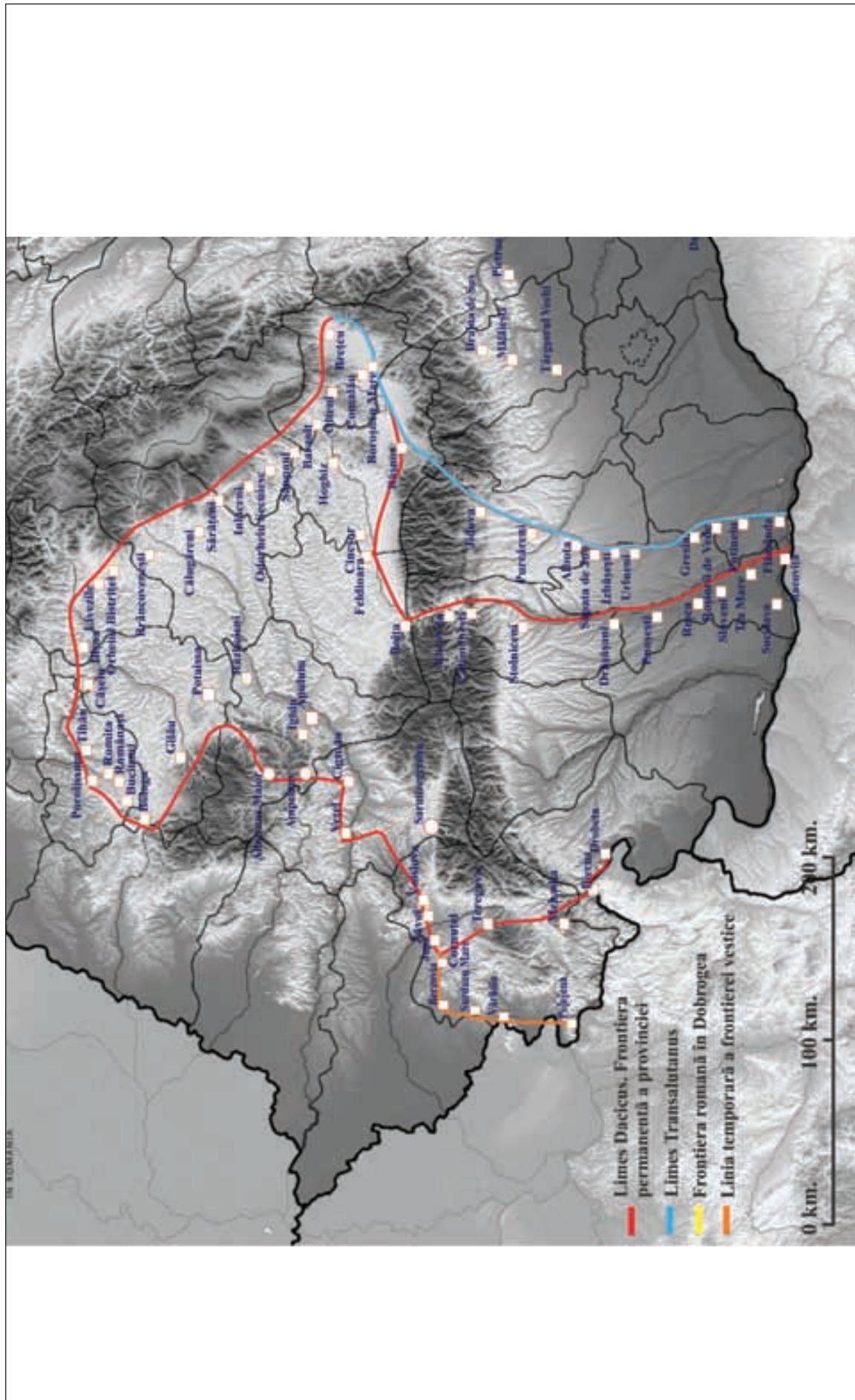

Pl. 1. The map of Roman Dacia based on the latest surveys, the fort at Buciumi being situated on the north-western sector of the Limes of Dacia Porolissensis. The permanent frontier line of the province is rendered with red. Source: <https://limestromania.ro/>

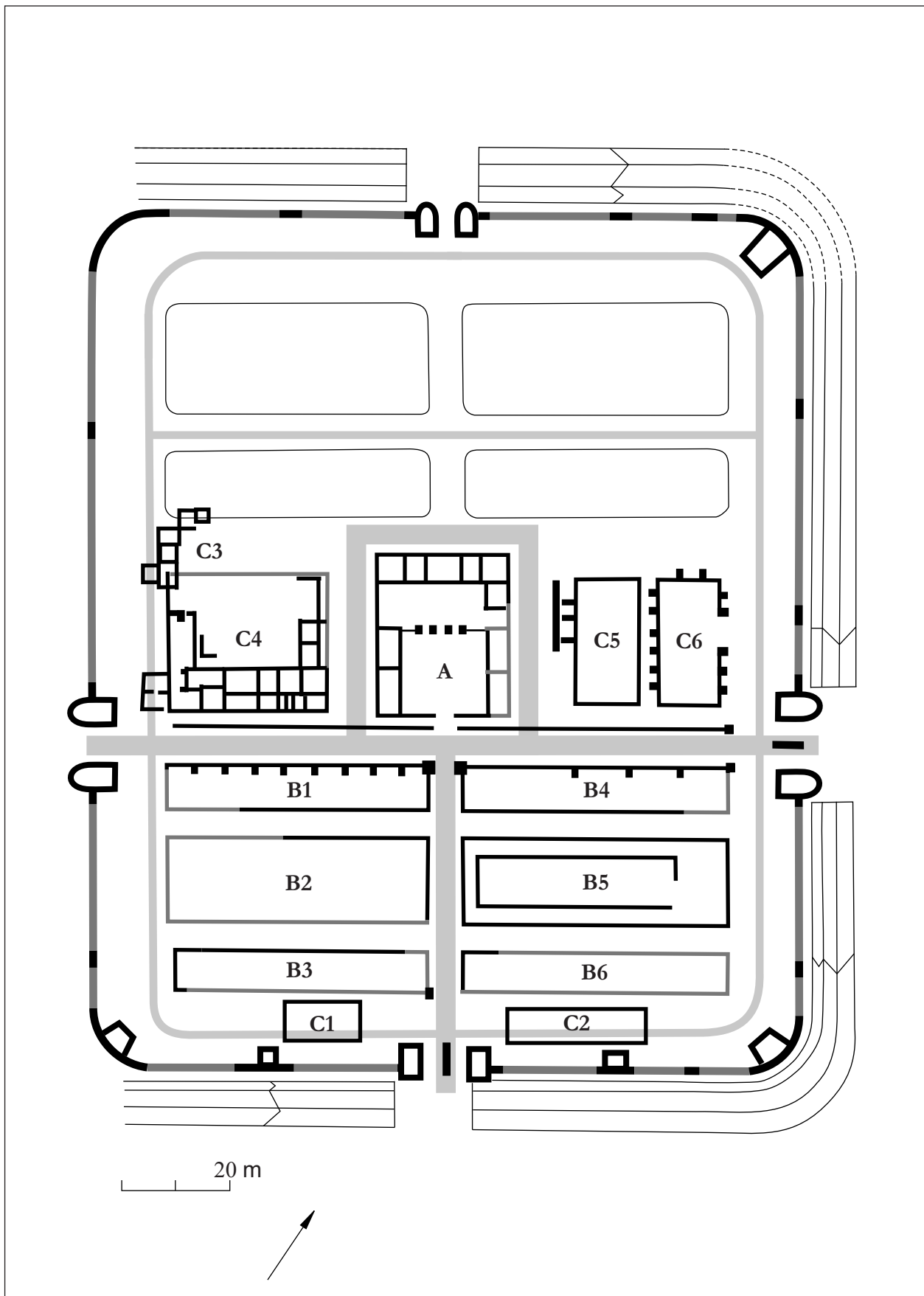

Pl. 2. The plan of the fort, redrawn after Gudea/Landes 1981. A: the headquarters building (*principia*); B 1–6: the barracks; C 1–2: storage buildings; C 3–4: the commanders' residence (*praetorium*); C 5–6: the granaries (*horrea*).

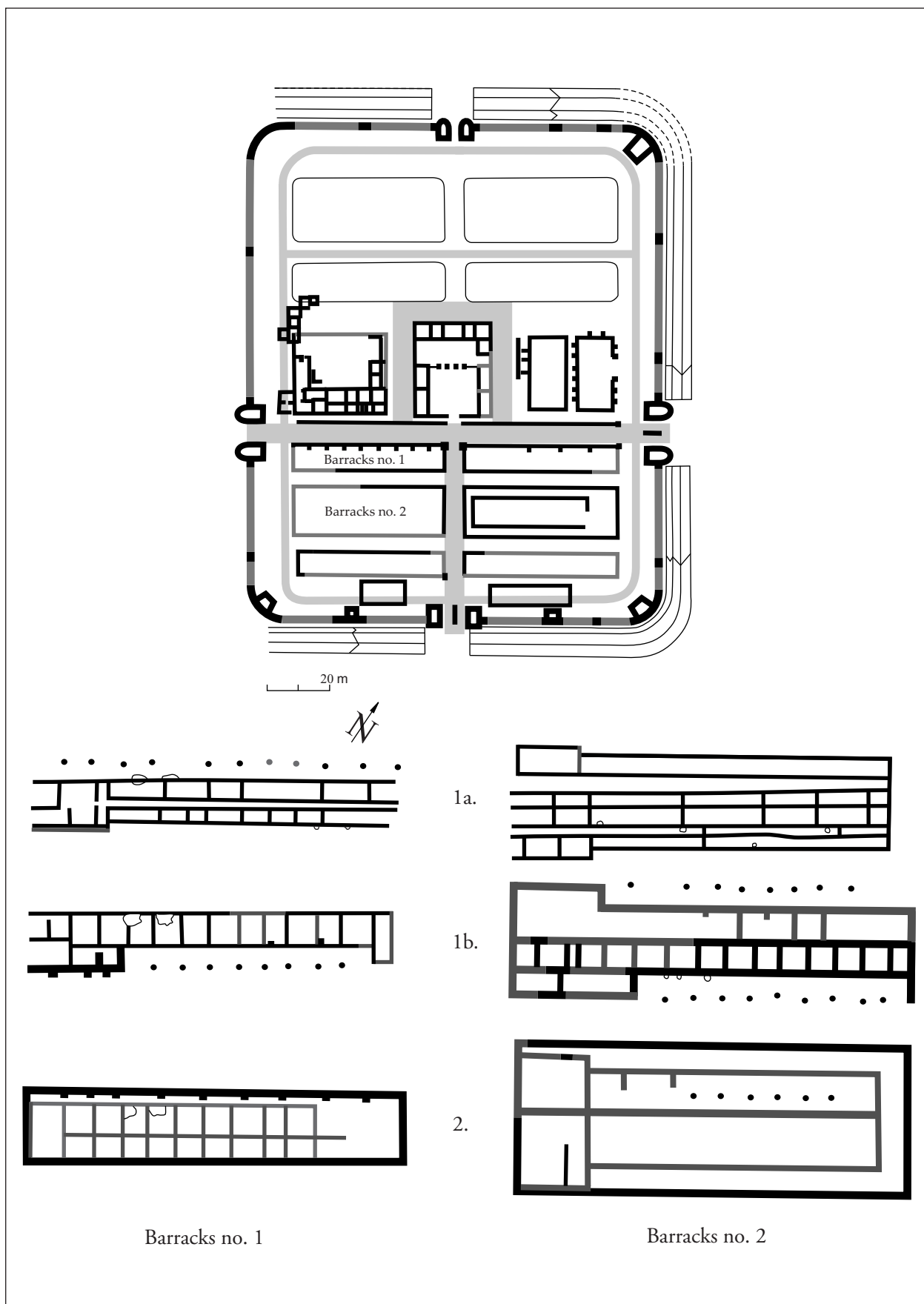

Pl. 3. The plan of barracks nos. 1 and 2 during the three identified construction/habitation phases (1a, 1b, and 2). Redrawn after Gudea 1997b.

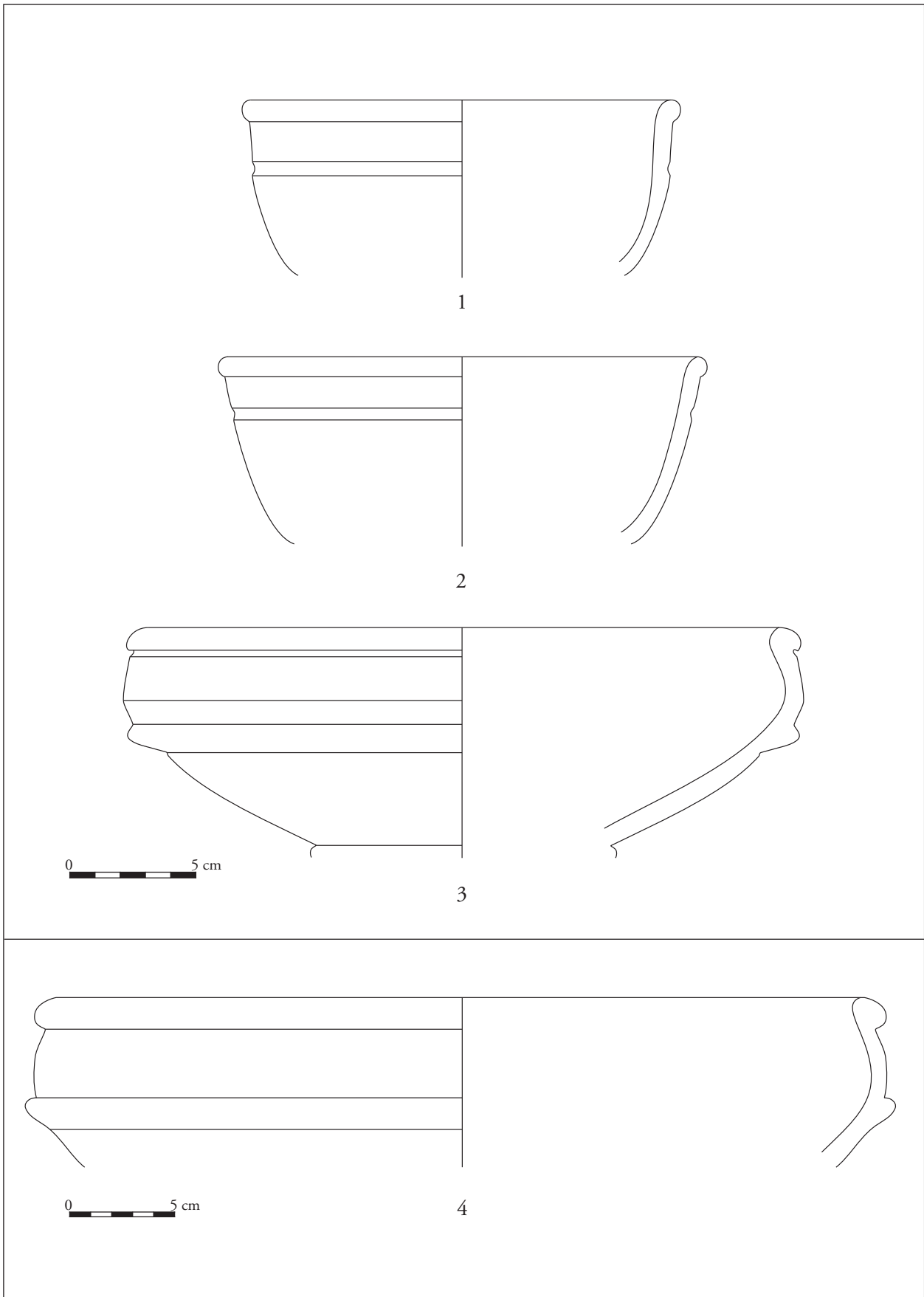

Pl. 4. The classification of the bowls (BO). 1–2: type BO 1; 3–4: type BO 2.

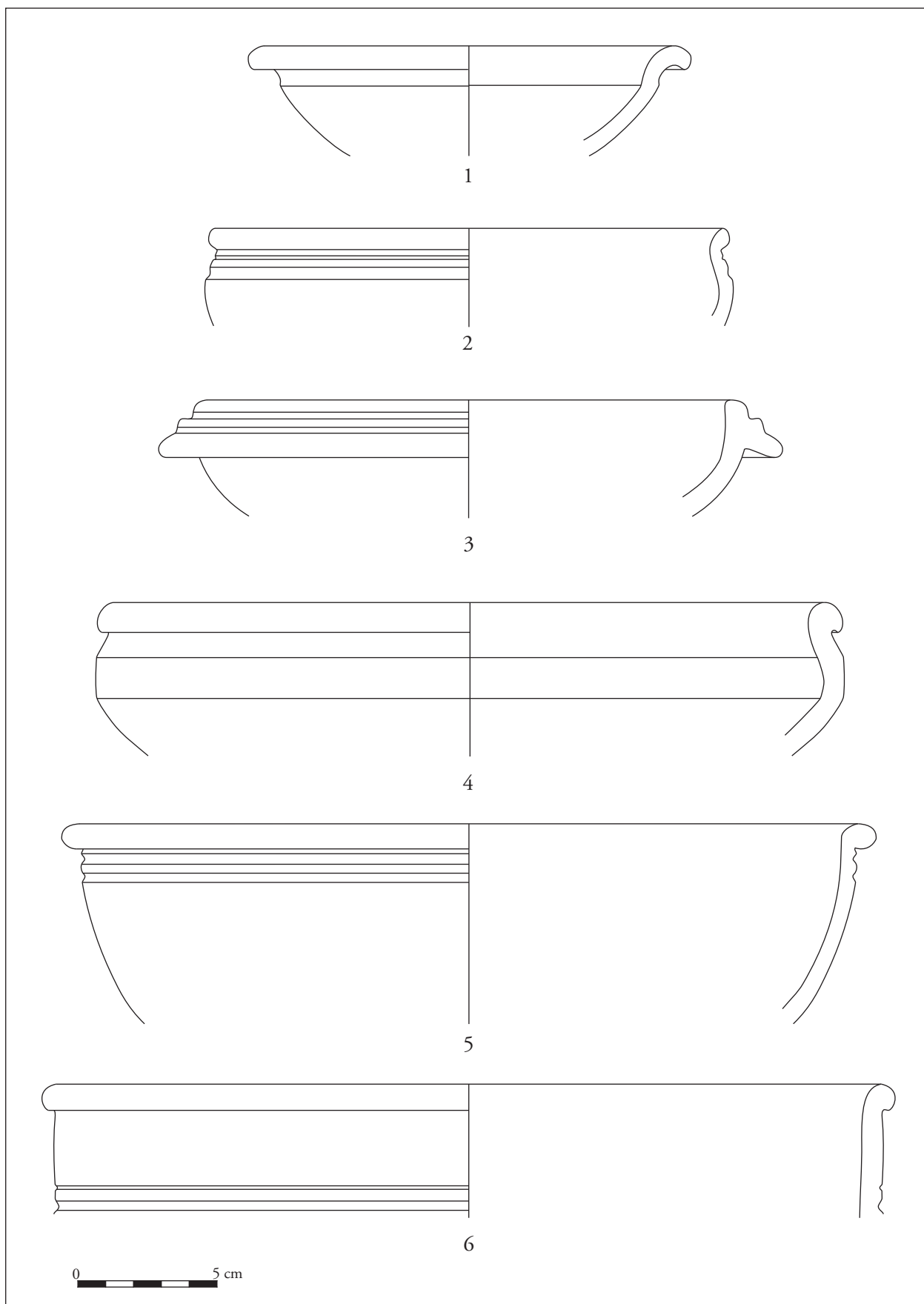

Pl. 5. The classification of the bowls (BO). 1: type BO 3; 2: type BO 4; 3: type BO 5; 4: type BO 6; 5: type BO 7; 6: type BO 1.

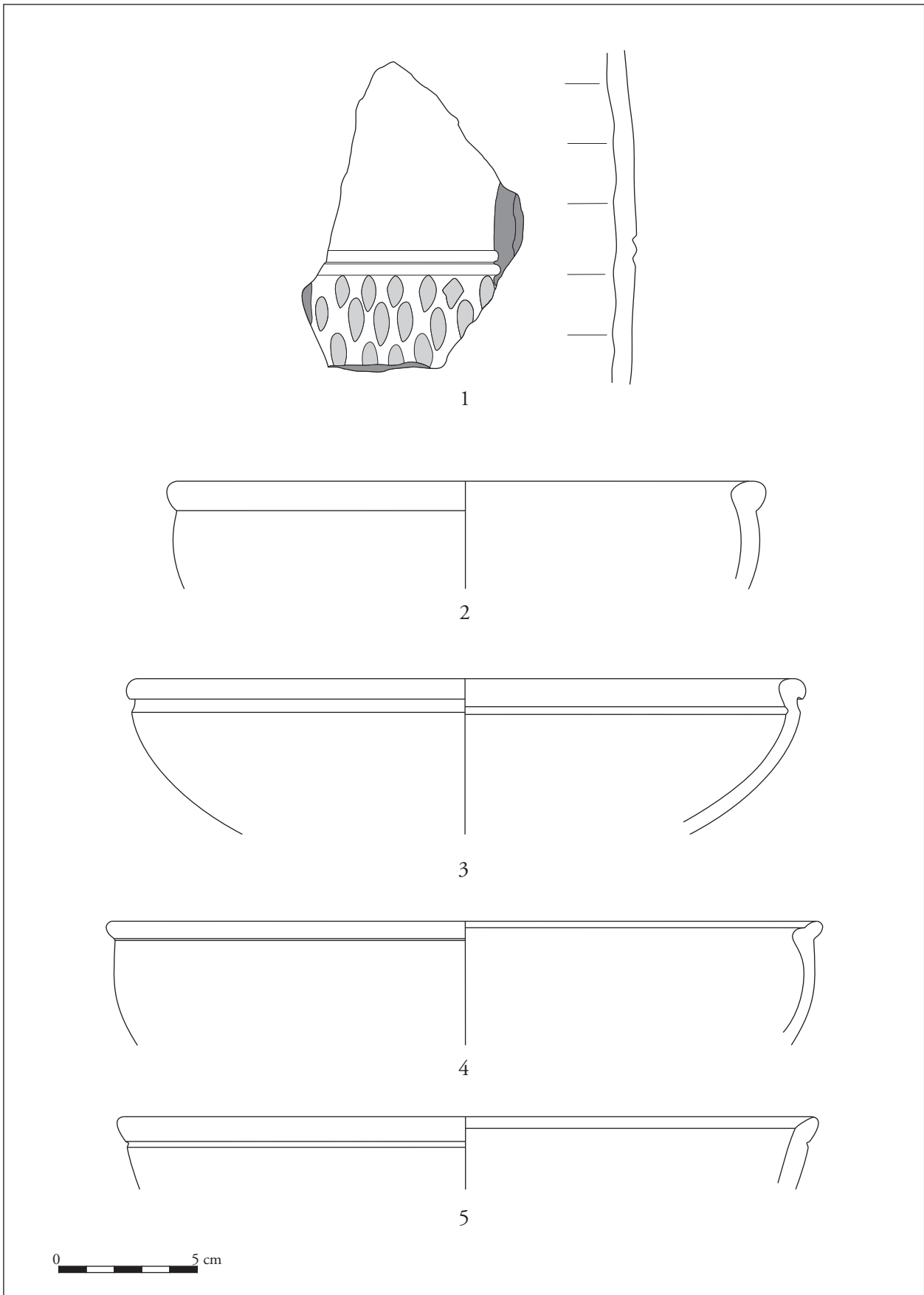

Pl. 6. The classification of the bowls (BO). 1: type BO 1 with cut-glass decoration; 2: type BO 8; 3: type BO 9; 4: type BO 10; 5: possible bowl (unclassified).

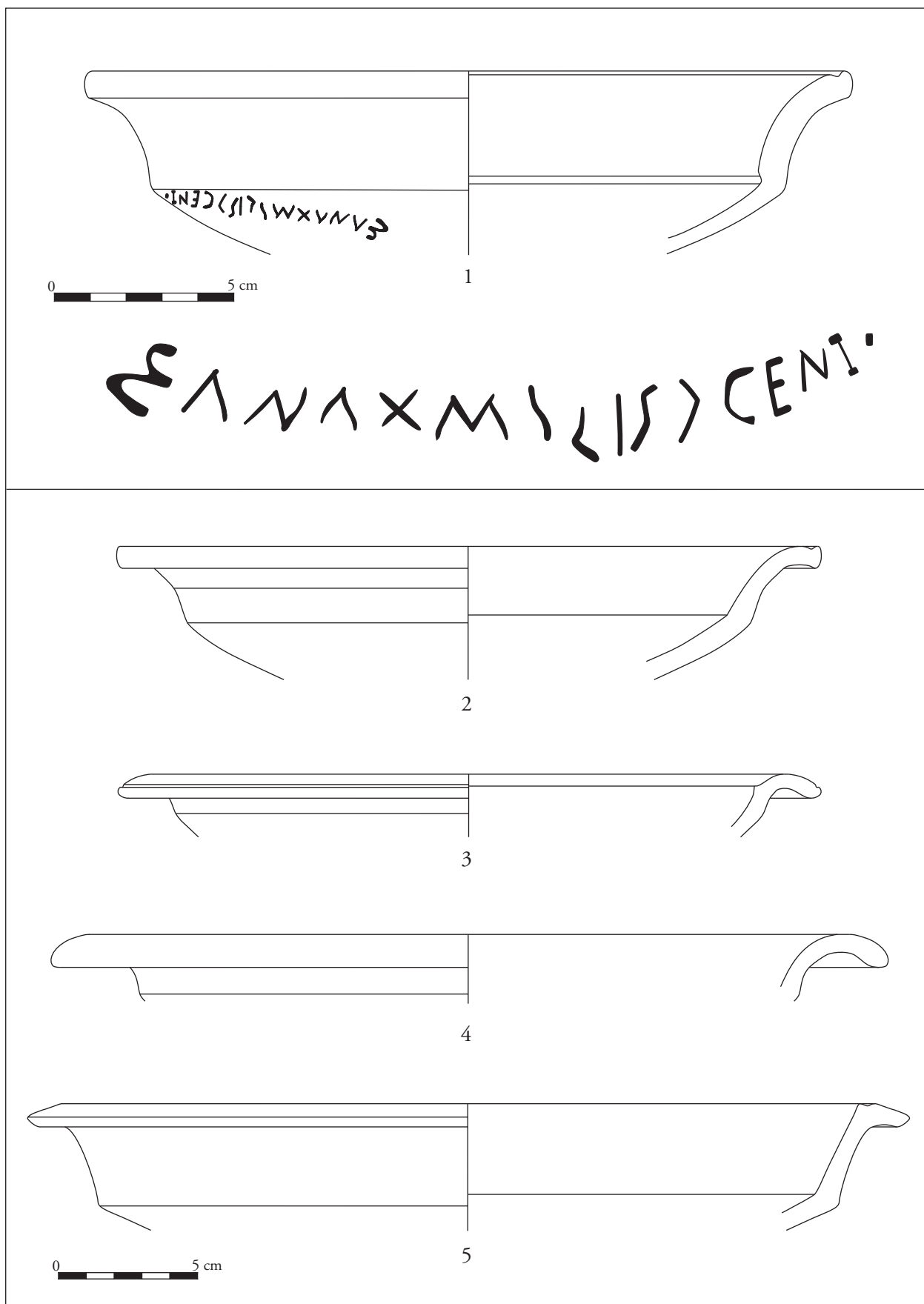

Pl. 7. The classification of the dishes (DI). 1–2: type DI 1 (no. 1 depicts a vessels displaying an ownership inscription, after Dana/Petruț 2015); 3–4: type DI 2; 5: type DI 3.

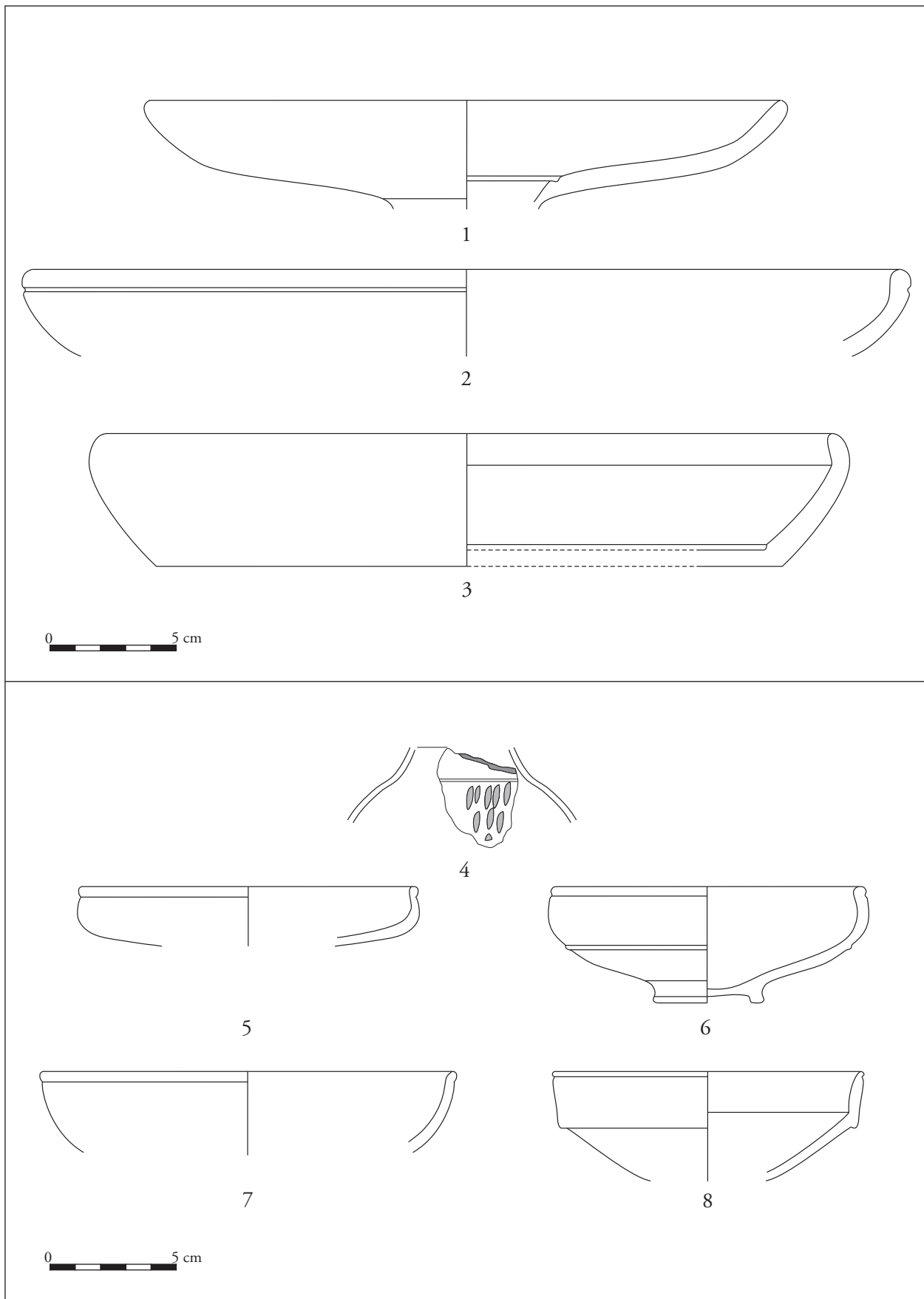

Pl. 8. The classification of the dishes (DI), platters (PL), beakers (BE), and cups (CU). 1: type DI 4; 2: type DI 5; 3: type PL 1; 4: type BE 1; 5–6: type CU 1; 7: type CU 2; 8: type CU 3.

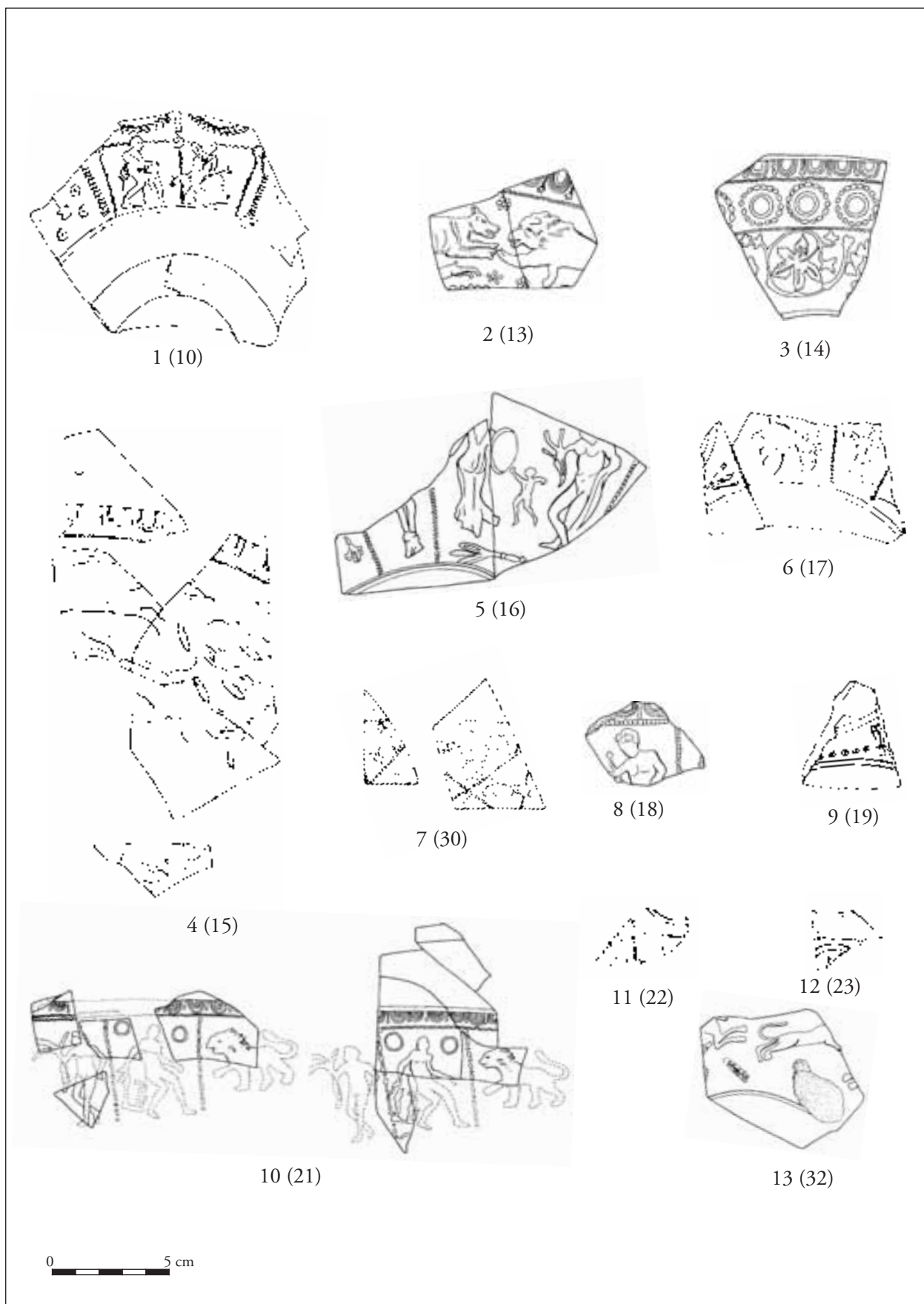

Pl. 9. Relief-decorated terra sigillata vessel fragments discovered between 1963 and 1970 (after Isac 1977). The catalogue numbers are given in brackets.

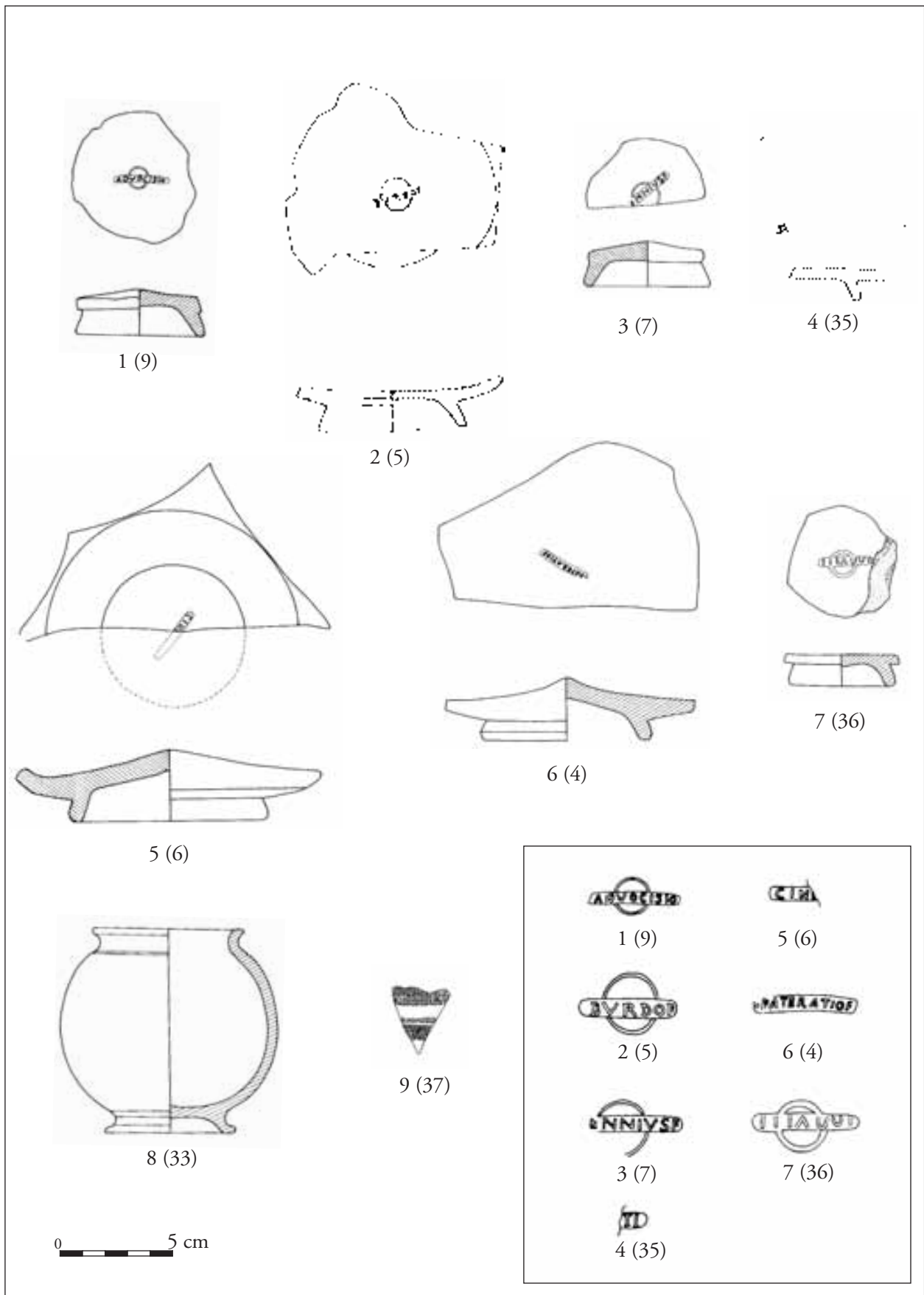

Pl. 10. Terra sigillata vessel fragments with potter's stamps discovered between 1963 and 1970, in addition to a restored intact container (8) and a roulette-decorated fragment (9) (after Isac 1977). The catalogue numbers are given in brackets.

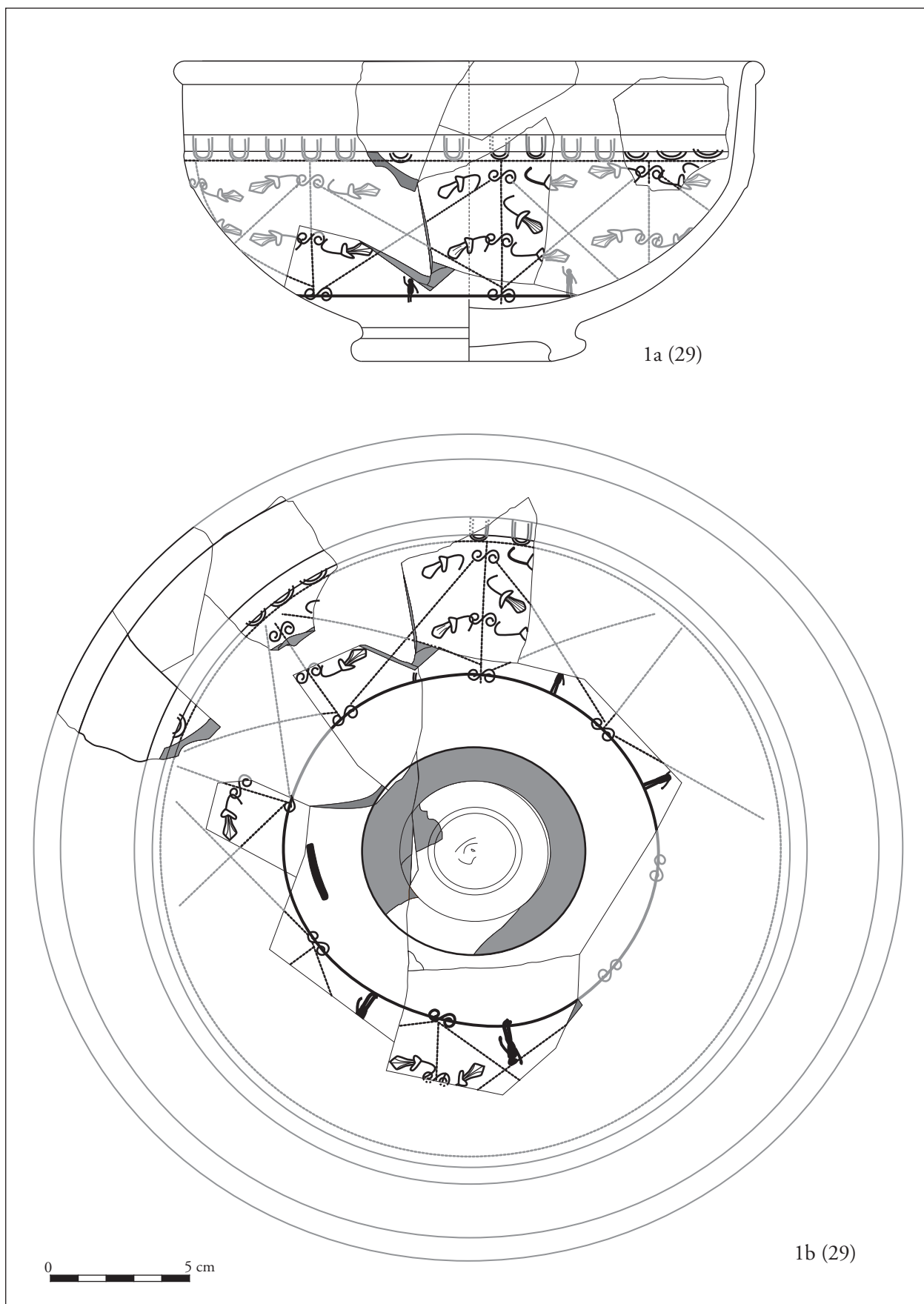

Pl. 11. Drag. 37 type bowl produced at Les Martres-de-Veyre (after Petruț 2014). The catalogue number is given in brackets.

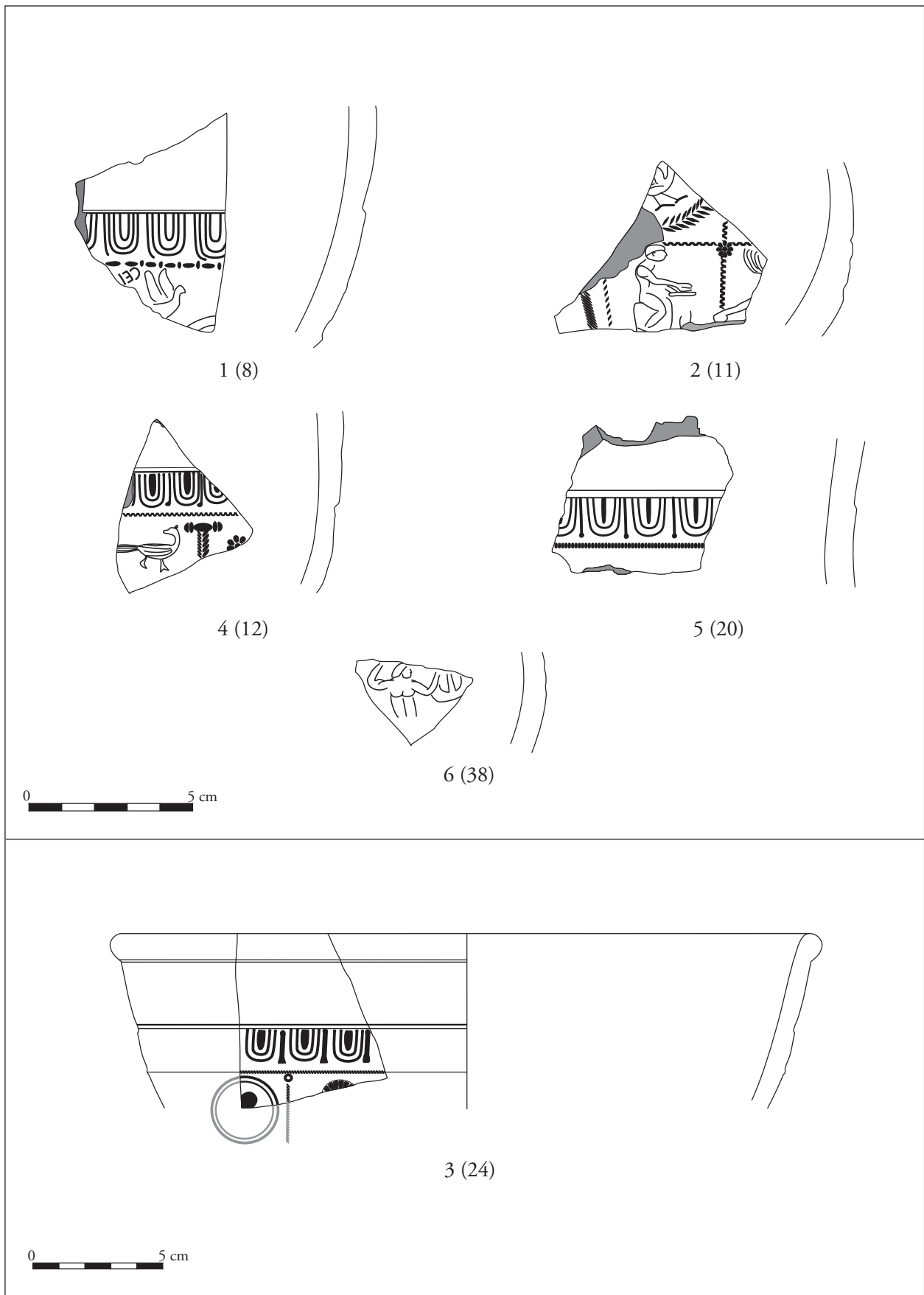

Pl. 12. Relief-decorated terra sigillata vessel fragments discovered between 1971 and 1976. The catalogue numbers are given in brackets.

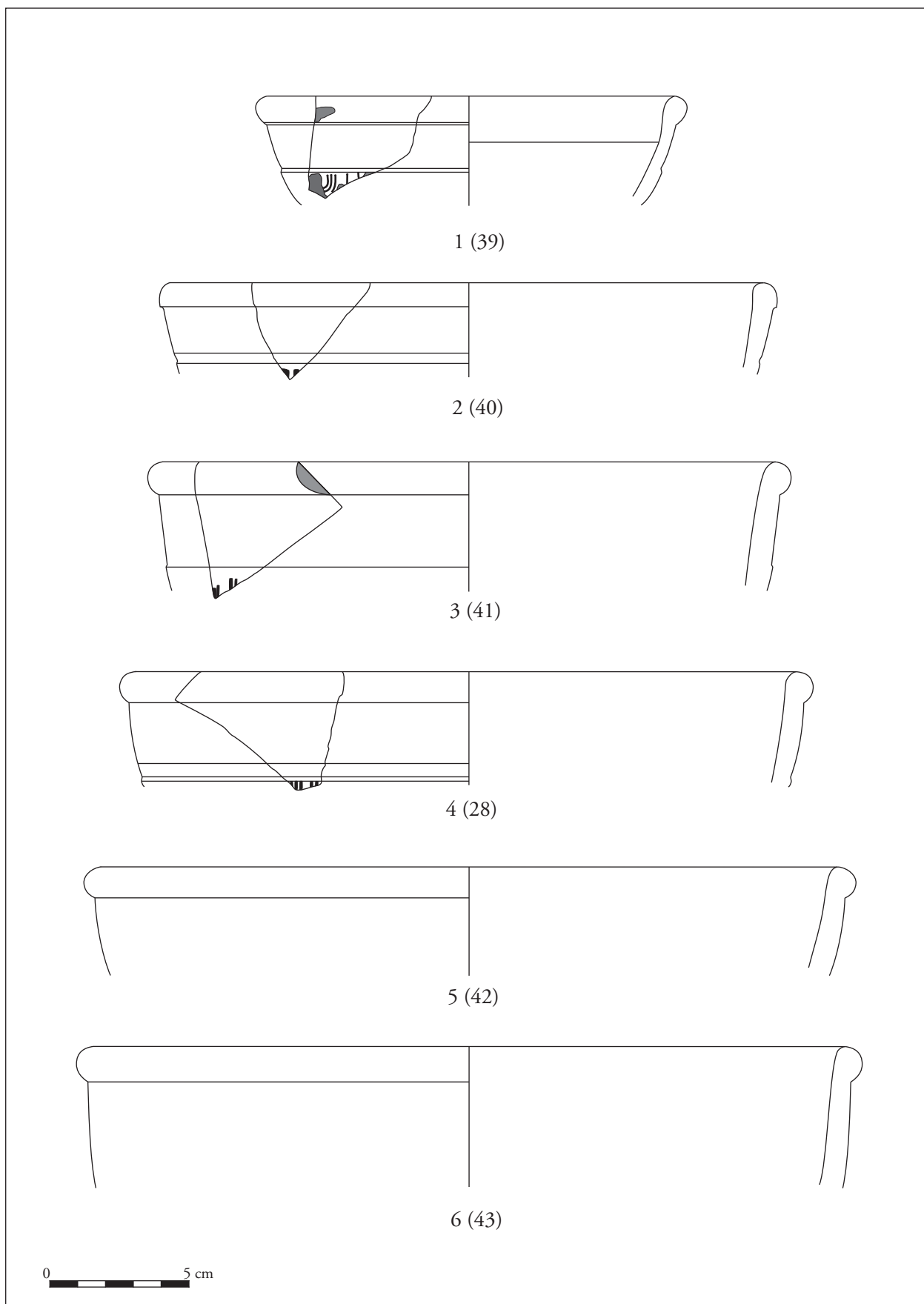

Pl. 13. Drag. 37 type terra sigillata vessel fragments discovered between 1971 and 1976. The catalogue numbers are given in brackets.

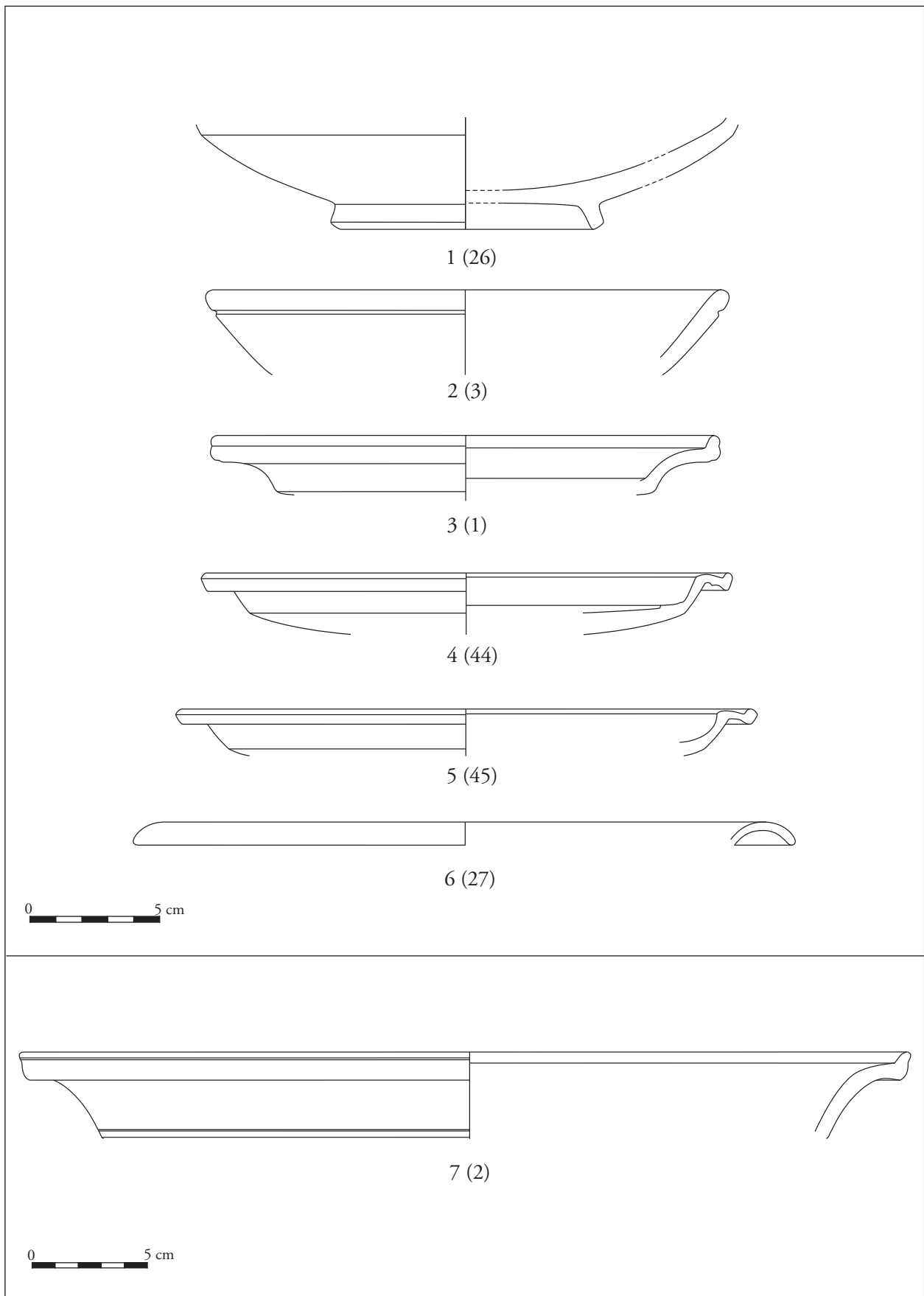

Pl. 14. Terra sigillata plainware vessel fragments discovered between 1971 and 1976. The catalogue numbers are given in brackets.

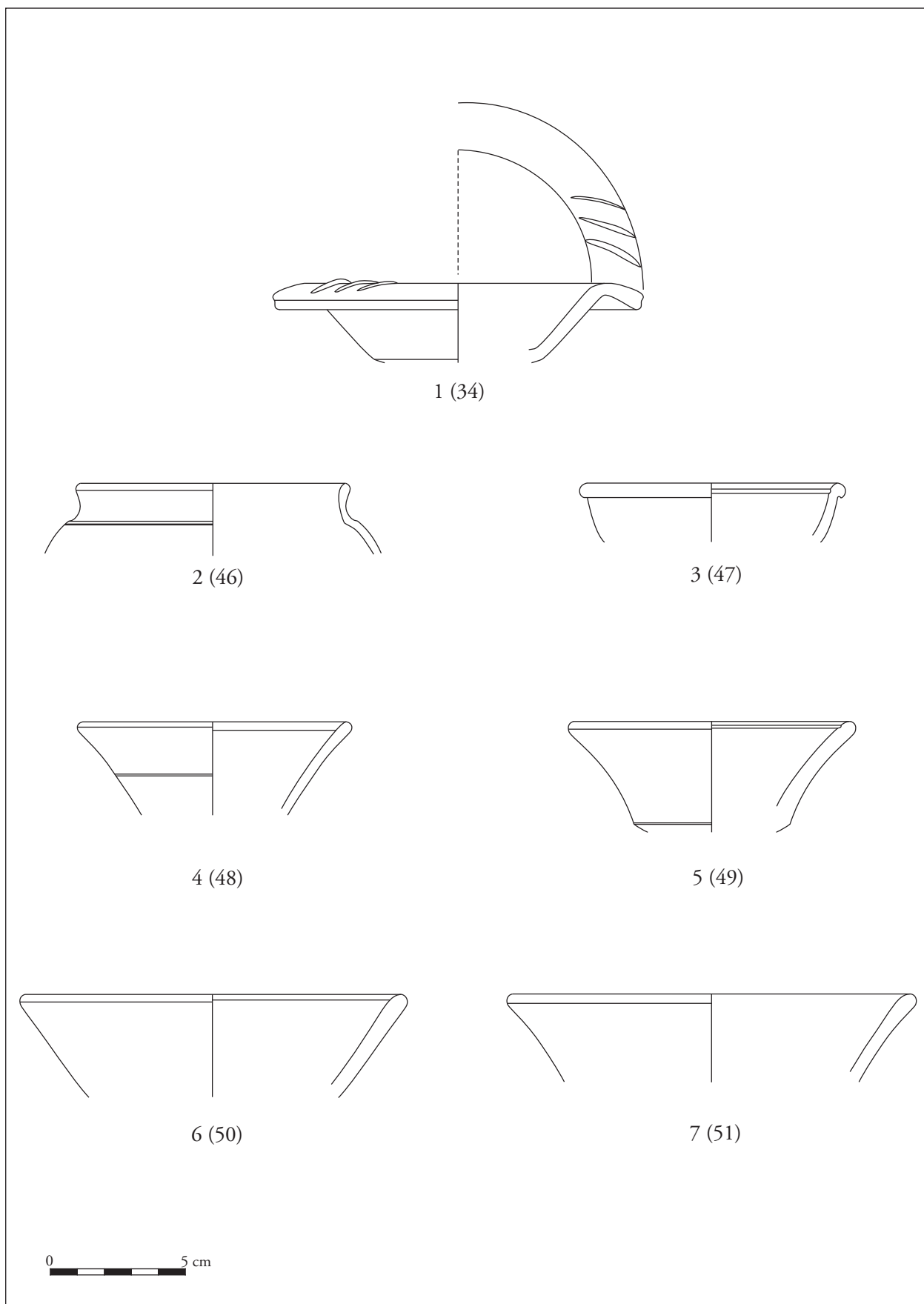

Pl. 15. Barbotine-decorated (1) and plainware terra sigillata vessel fragments discovered between 1971 and 1976. The catalogue numbers are given in brackets.

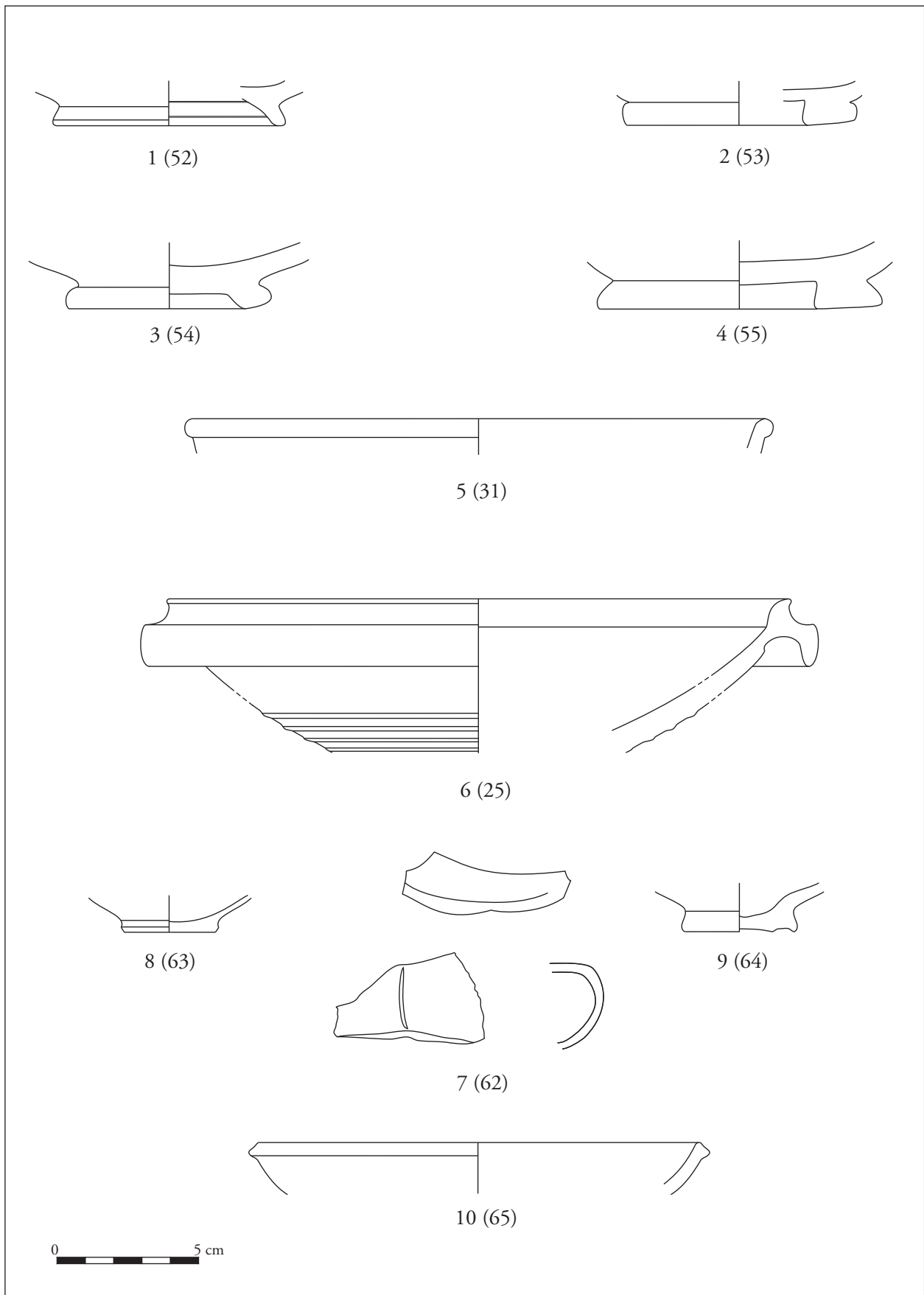

Pl. 16. Terra sigillata plainware vessel fragments, thin-walled (8), and lead-glazed vessels (9 and 10) discovered between 1971 and 1976. The catalogue numbers are given in brackets.

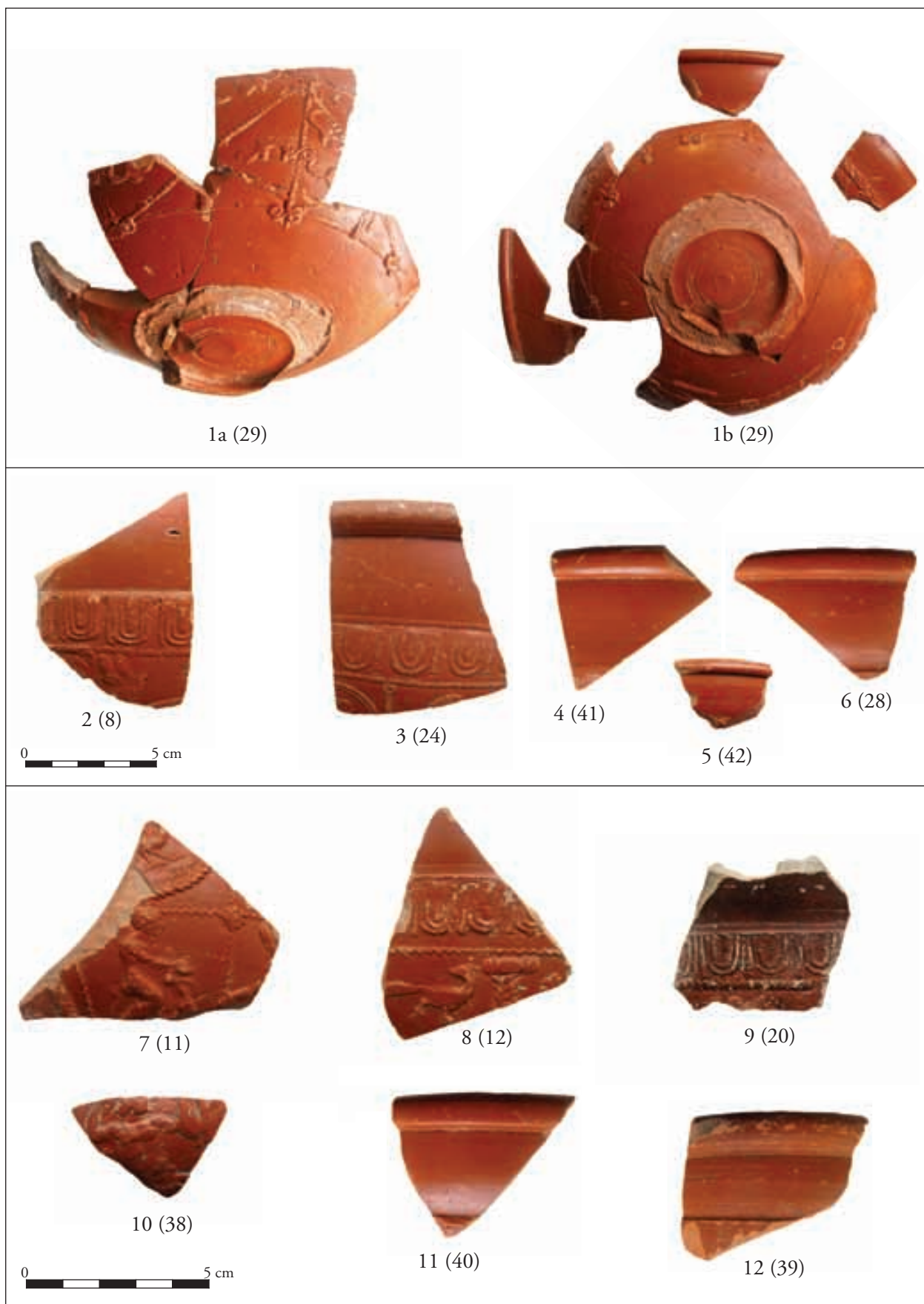

Pl. 17. Relief-decorated terra sigillata vessel fragments discovered between 1971 and 1976. The catalogue numbers are given in brackets.



Pl. 18. Barbotine-decorated (8) and plainware terra sigillata vessel fragments discovered between 1971 and 1976. The catalogue numbers are given in brackets.



Pl. 19. Terra sigillata plainware vessel fragments discovered between 1971 and 1976, in addition to fragments of lead-glazed ware (8) and local cut-glass-decorated tableware (9, 10). The catalogue numbers are given in brackets.

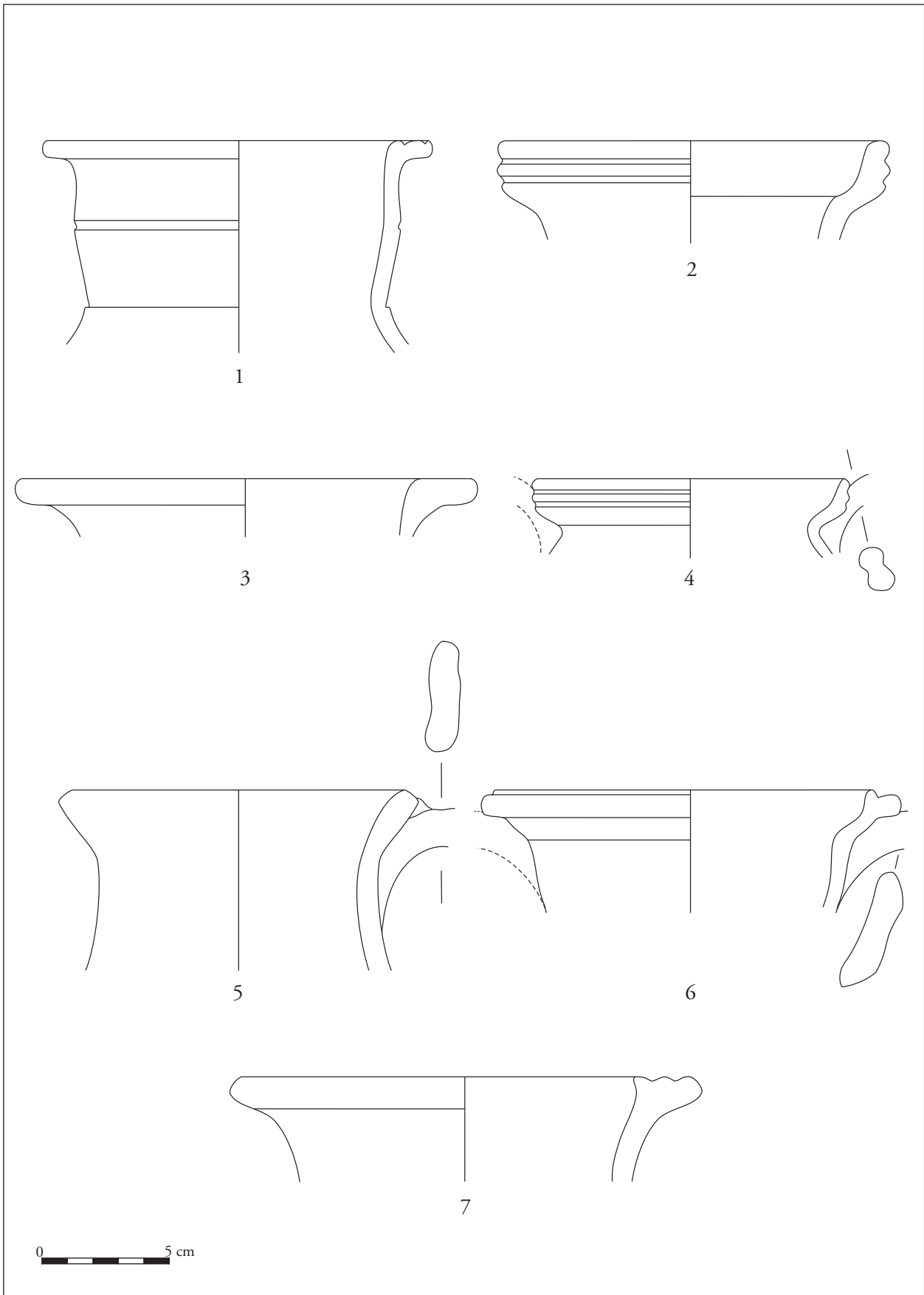

Pl. 20. The classification of the jugs (JU). 1: type JU 3; 2: type JU 2; 3: type JU 3; 4: type JU 4; 5: type JU 5; 6: type JU 6; 7: type JU 7.

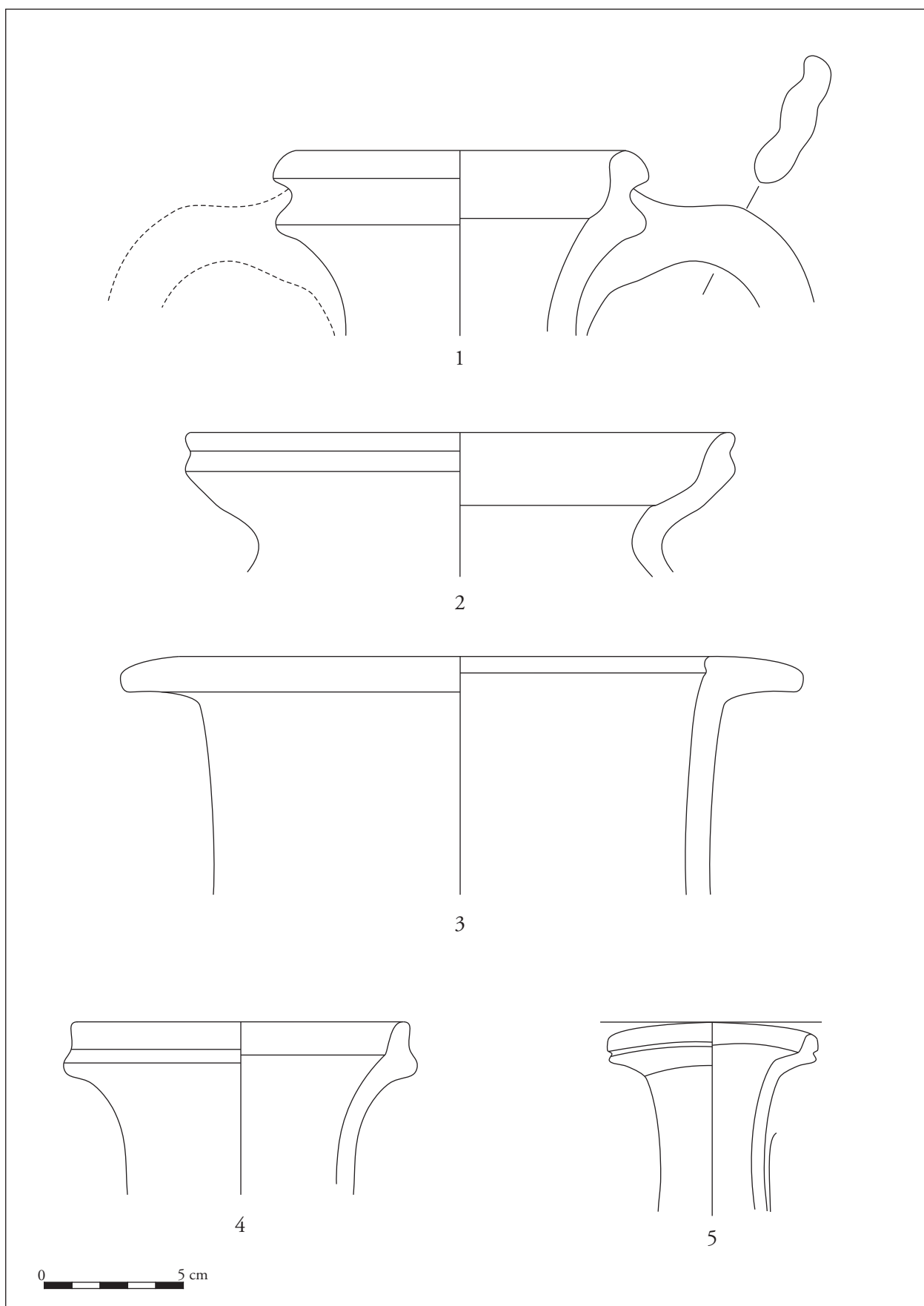

Pl. 21. The classification of the jugs (JU) and flagons (FL). 1: type JU 8; 2: type JU 9; 3: type JU 10; 4: type FL 1; 5: type FL 2.

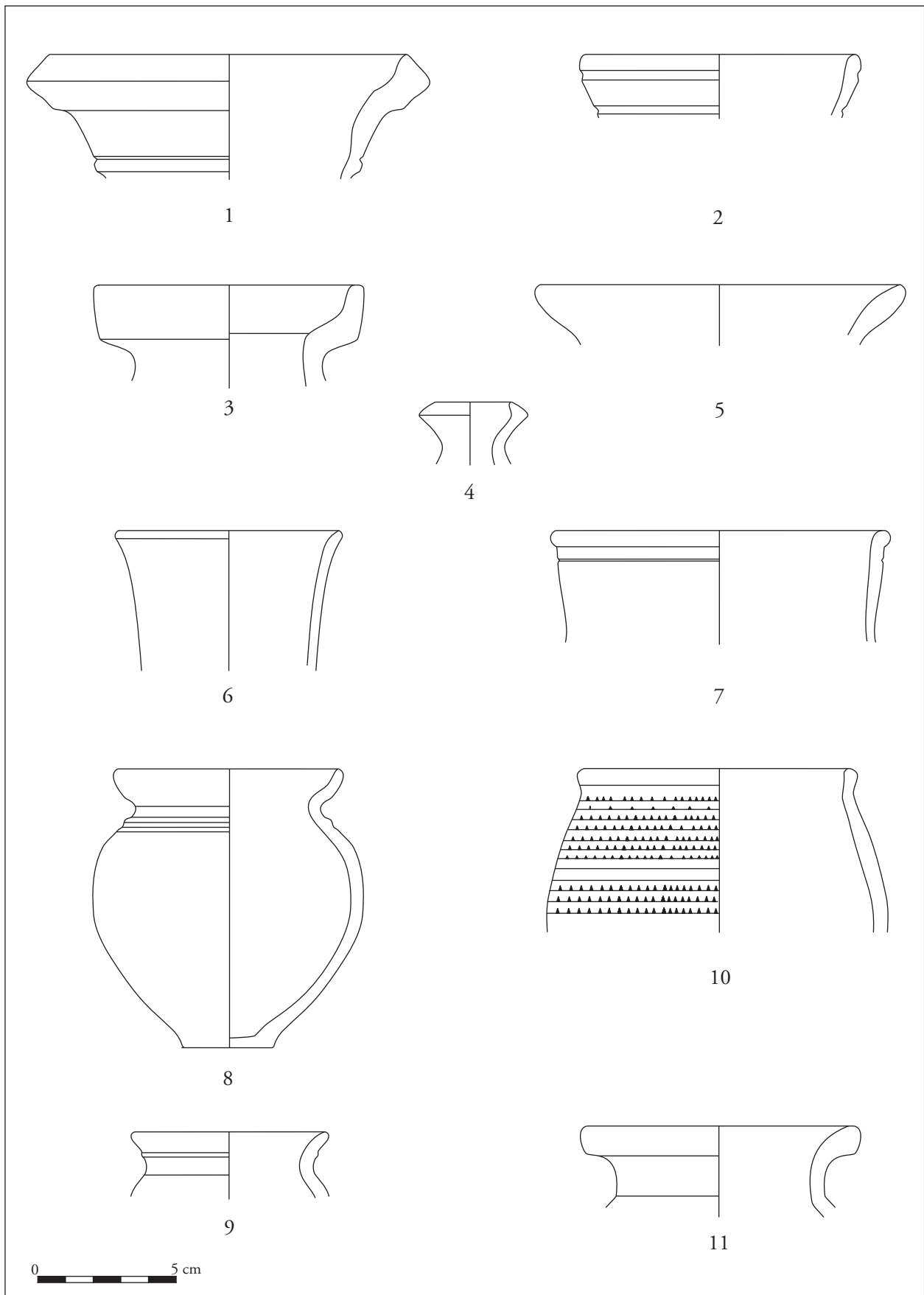

Pl. 22. The classification of the flagons (FL) and jars (JA). 1: type FL 3; 2: type FL 4; 3: type FL 5; 4: type FL 6; 5: type FL 7; 6: type FL 8; 7: type FL 9; 8: type JA 1; 9: type JA 2; 10: type JA 3; 11: type JA 4.

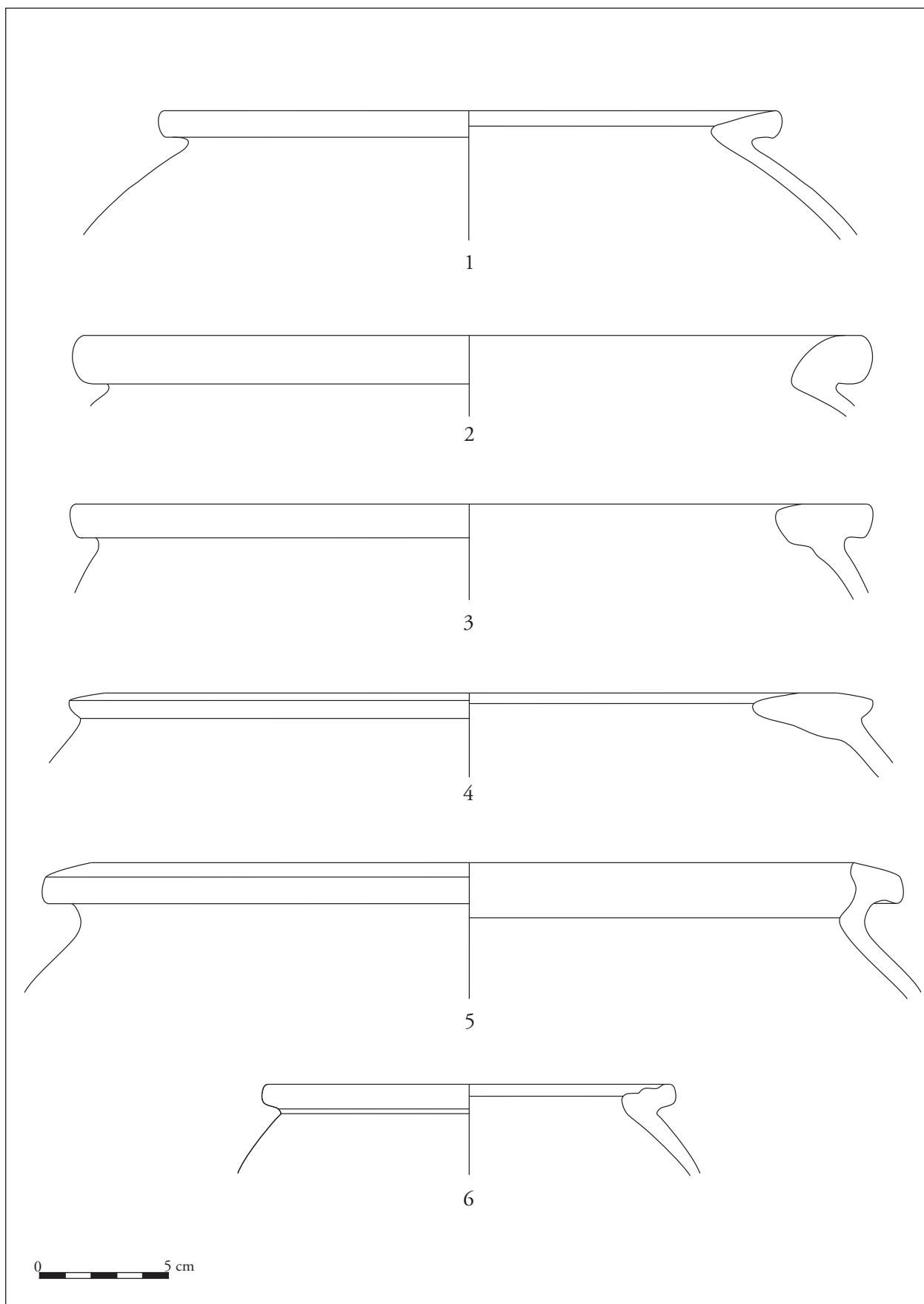

Pl. 23. The classification of the *dolia* (DO). 1: type DO 1; 2: type DO 2; 3: type DO 3; 4: type DO 4; 5: type DO 5; 6: type DO 6.

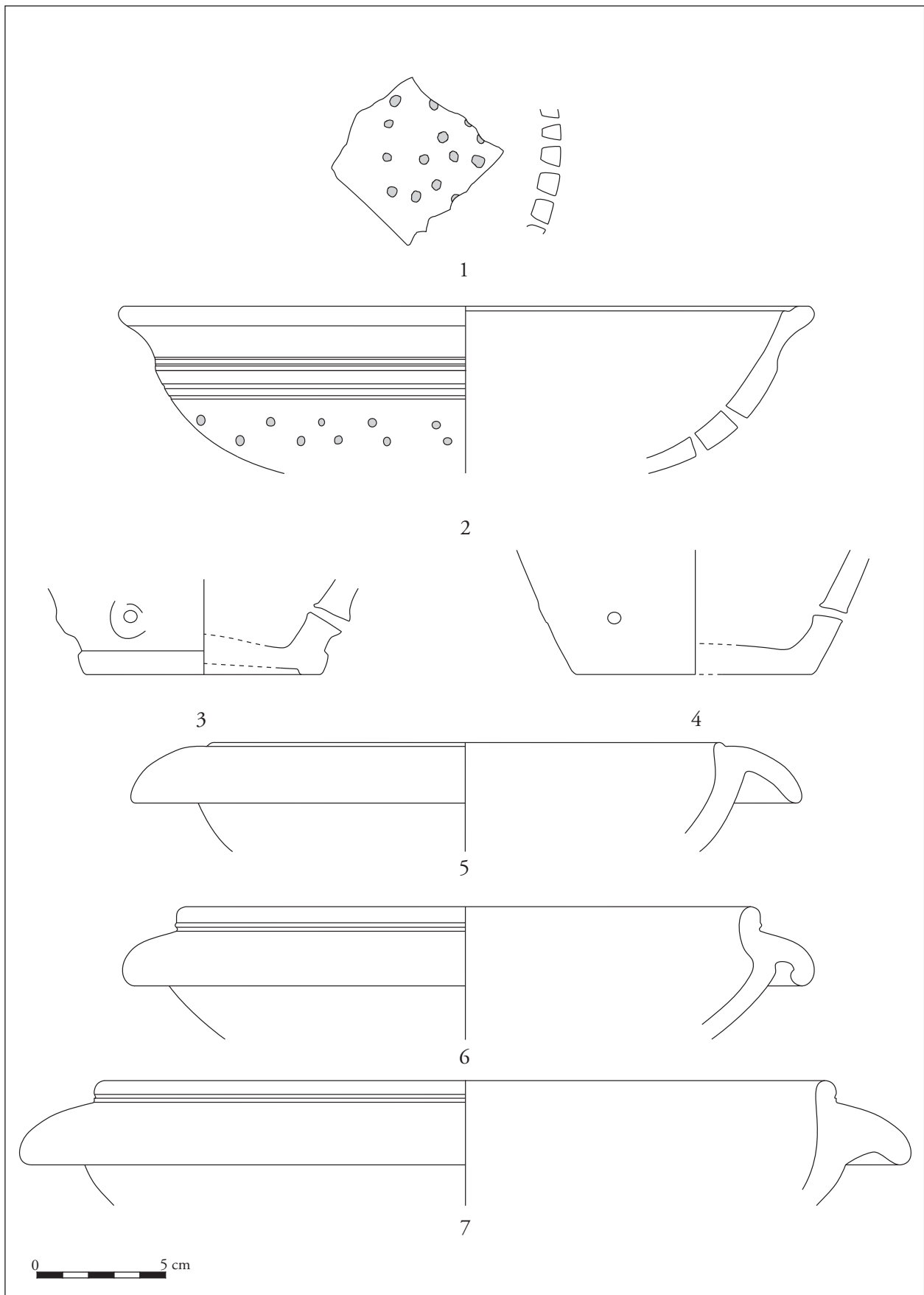

Pl. 24. The classification of the strainers (ST) and *mortaria* (MO). 1: strainer wall fragment (unclassified); 2: type ST 1; 3–4: type ST 2; 5: type MO 1; 6: type MO 2; 7: type MO 3.

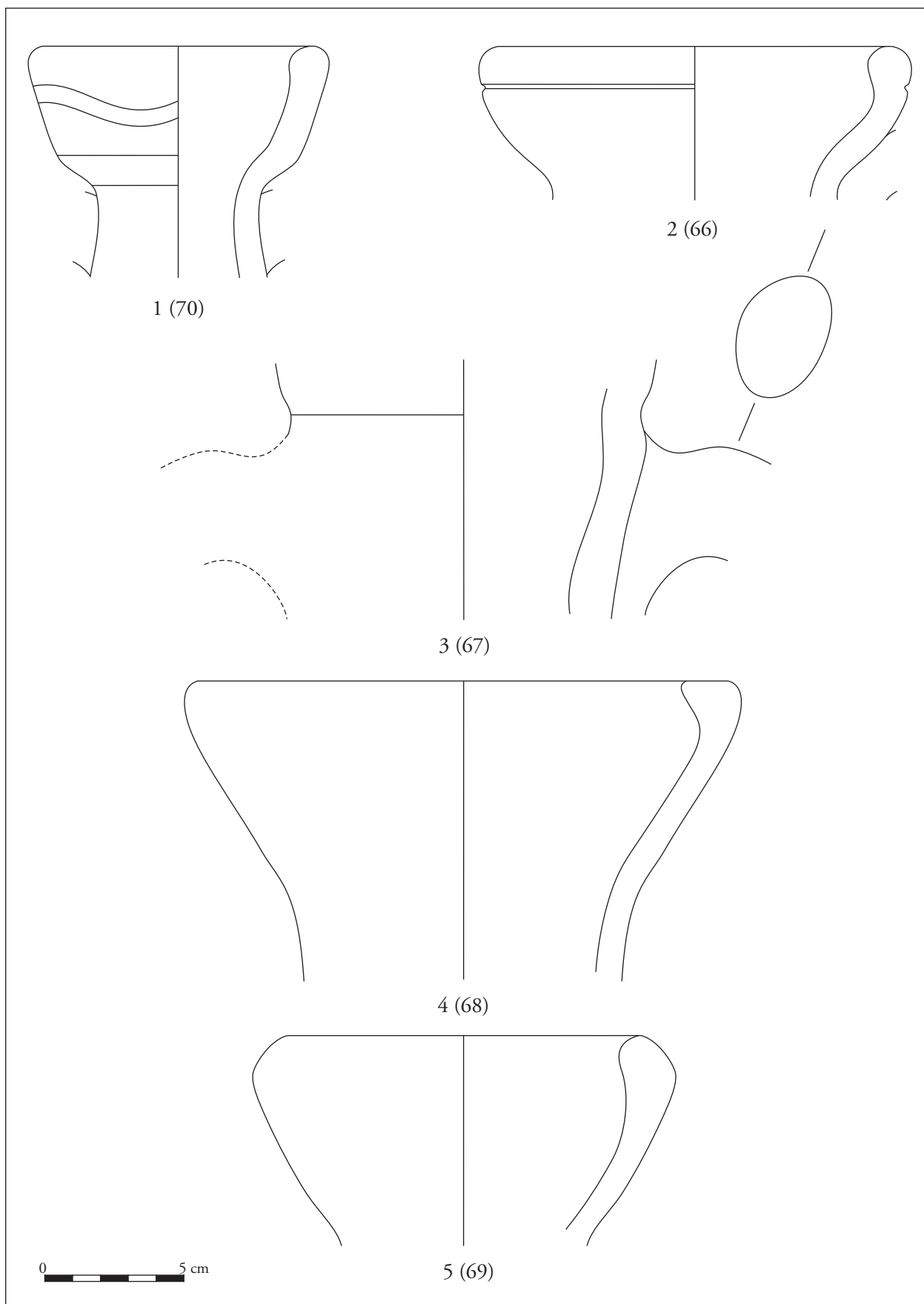

Pl. 25. The classification of the amphorae. 1: Aquincum 78; 2–3: Dressel 6B; 4–5: Zeest 90/Dressel 24. The catalogue numbers are given in brackets.



Pl. 26. The classification of the amphorae. 1: Aquincum 78; 2–3: Dressel 6B; 4–5: Zeest 90/Dressel 24. The catalogue numbers are given in brackets.

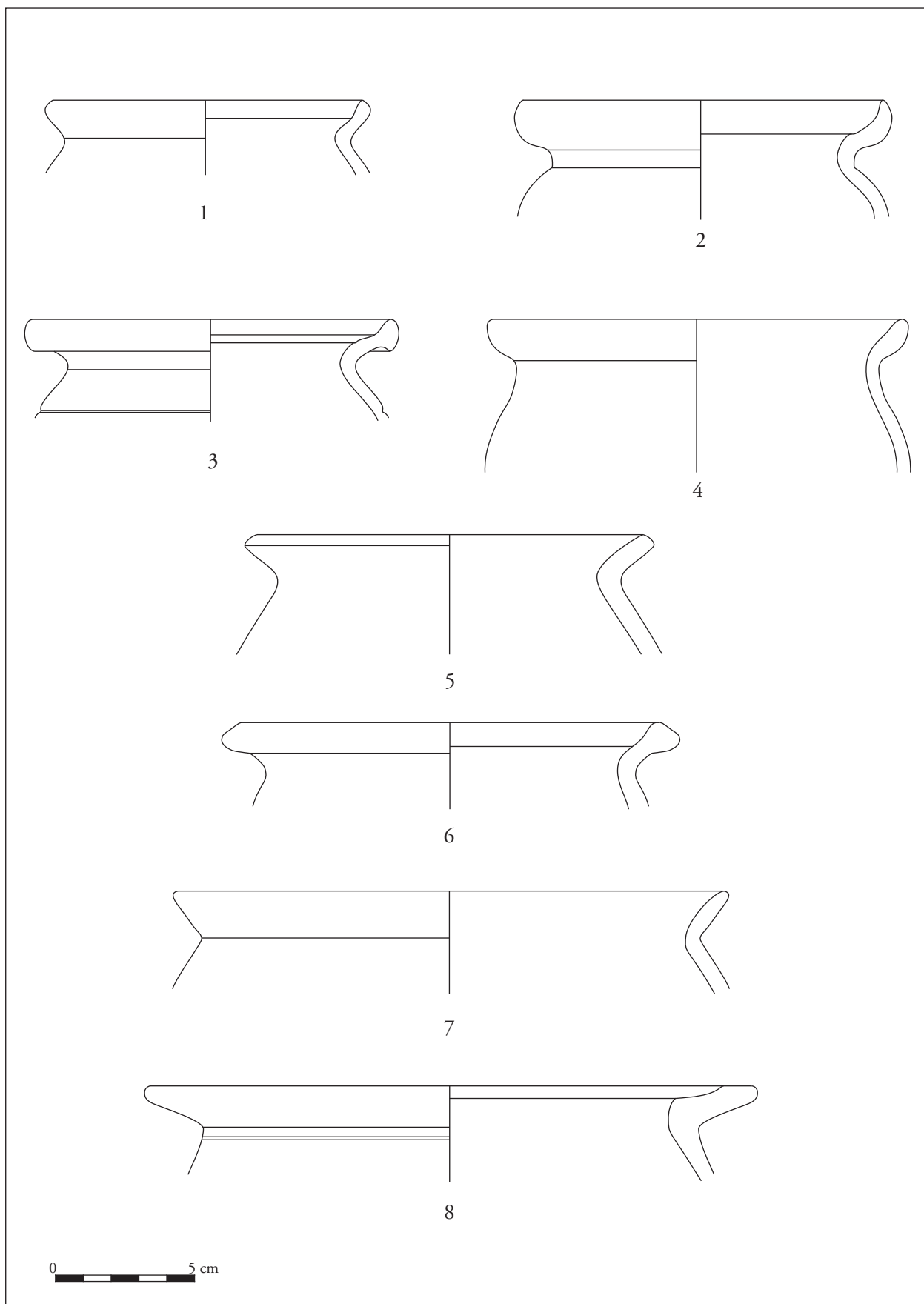

Pl. 27. The classification of the pots (PO). 1: type PO 1; 2: type PO 2; 3: type PO 3; 4: type PO 4; 5: type PO 5; 6: type PO 6; 7: type PO 7; 8: type PO 8.

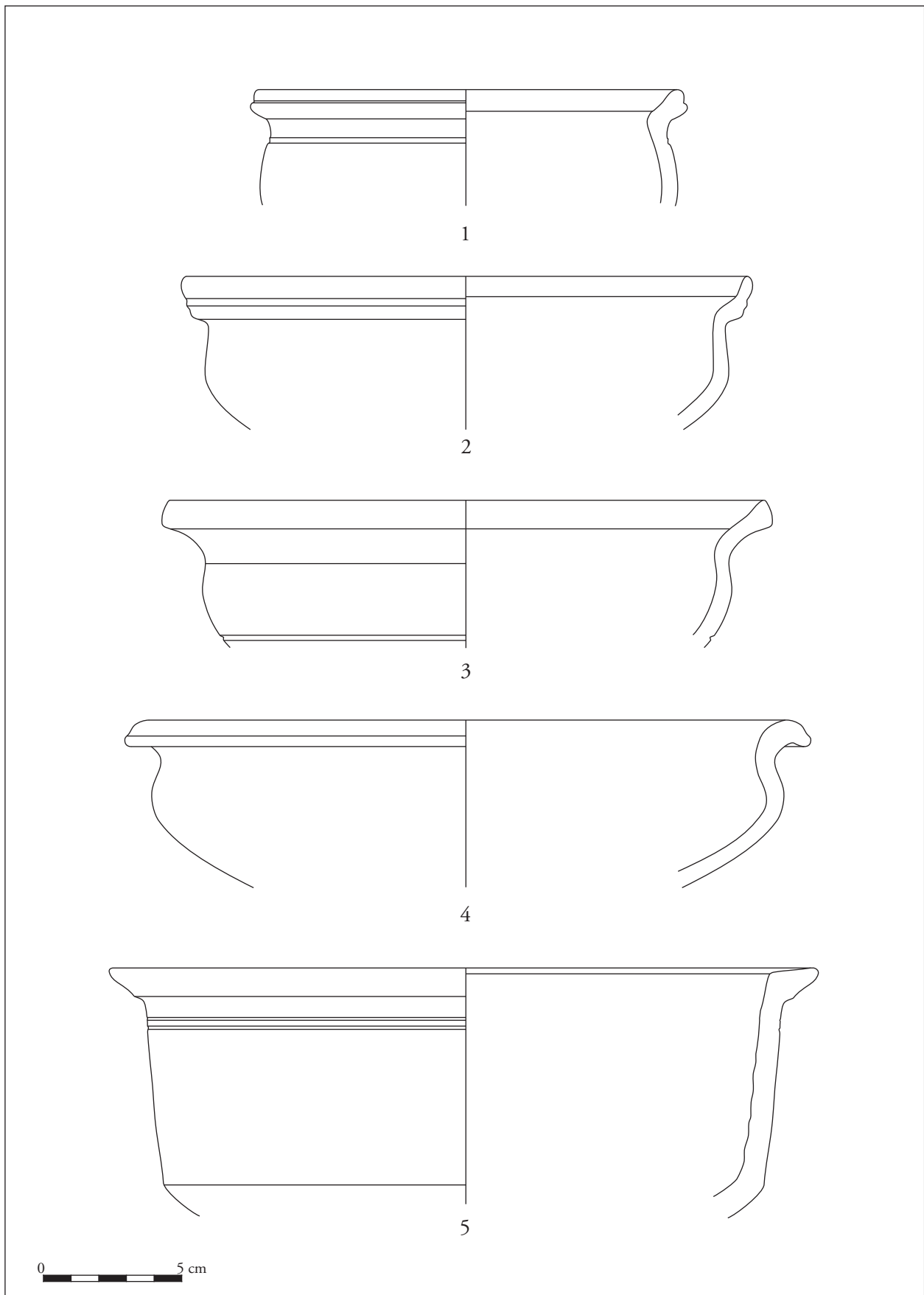

Pl. 28. The classification of the casseroles (CA). 1: type CA 1; 2: type CA 2; 3: type CA 3; 4: type CA 4; 5: type CA 5.

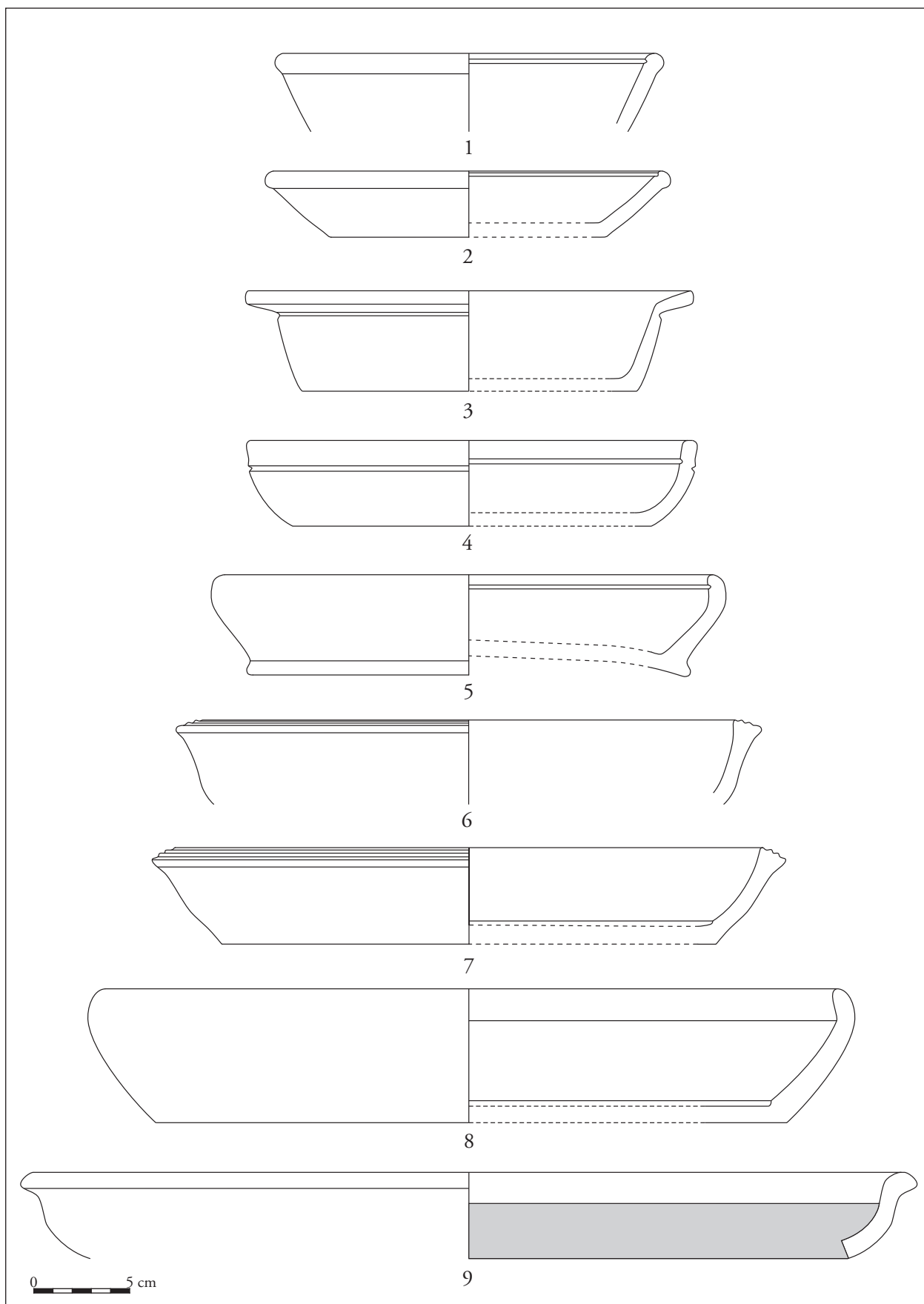

Pl. 29. The classification of the pans (PA). 1–2: type PA 1; 3: type PA 2; 4: type PA 3; 5: type PA 4; 6–7: type PA 5; 8: type PA 6; 9: type PA 7.

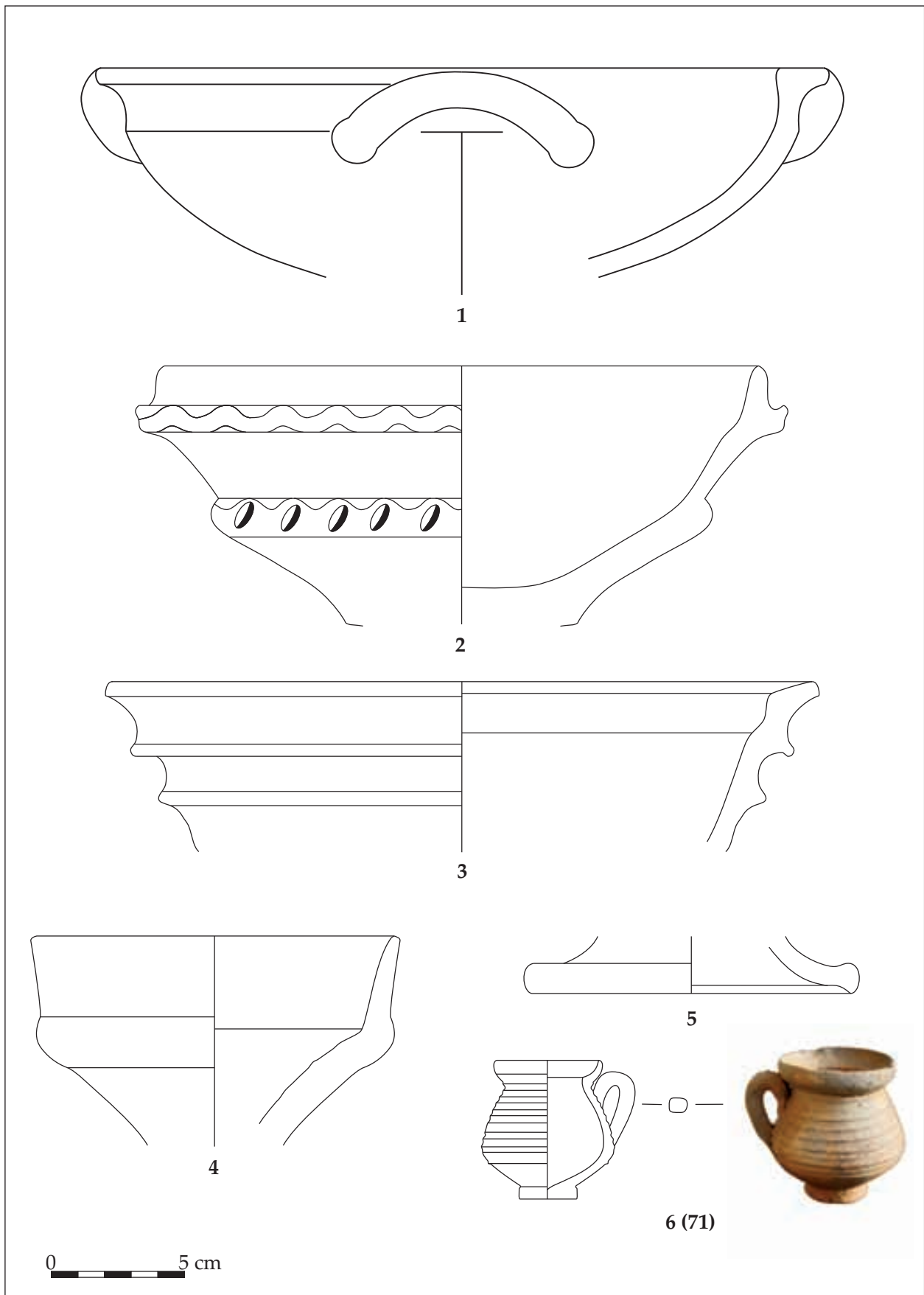

Pl. 30. Non-food-related containers. 1: hemispherical washing basin; 2–5: incense burners (*turibula*); 6: miniature beaker. The catalogue numbers are given in brackets.

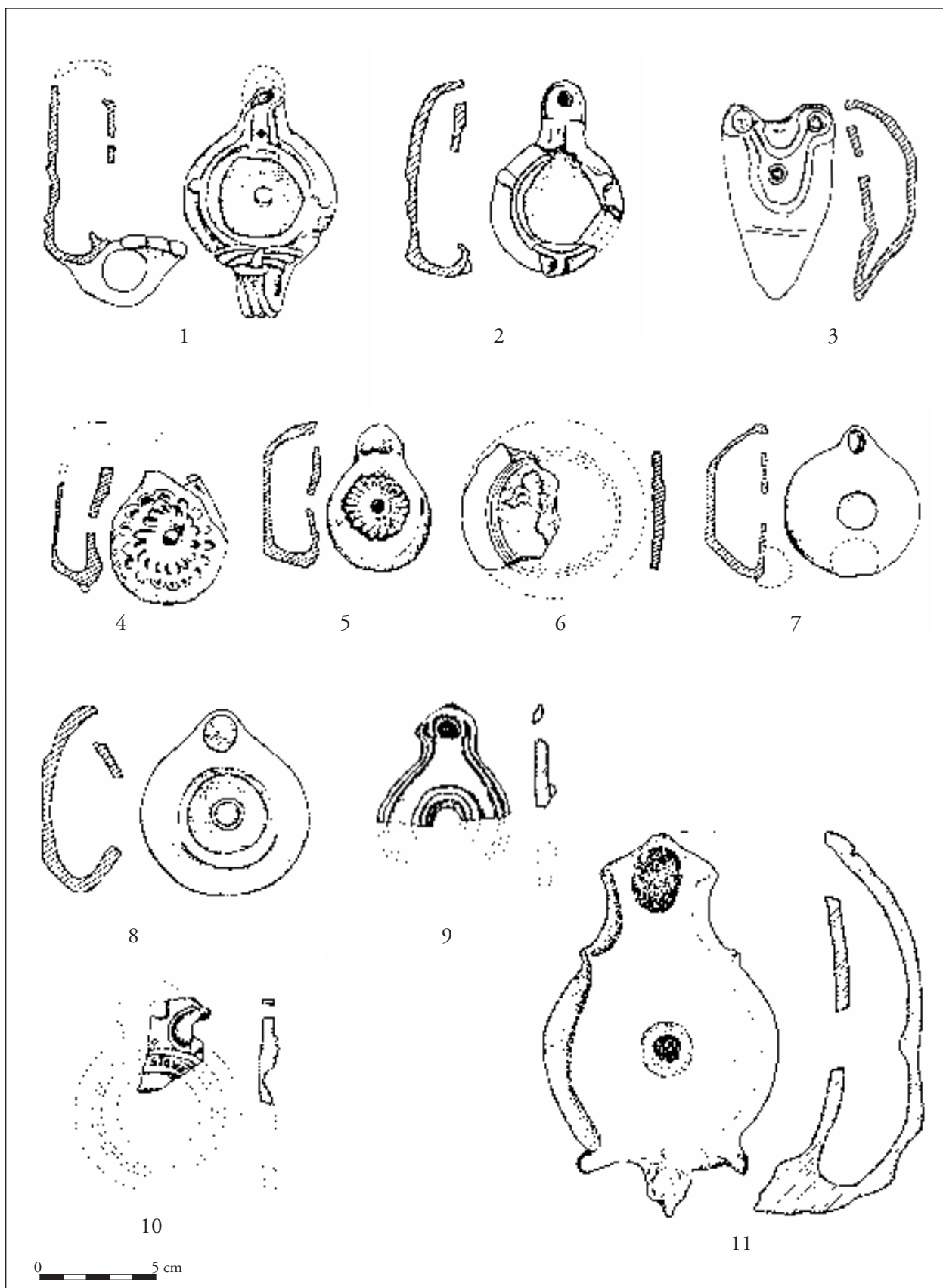

Pl. 31. The main lamp types discovered between 1963 and 1970 (after Gudea/Cosma 2008). 1–3: Firmalampen (Loeschcke type IX–X); 4–5: Provincial ‘pear-shaped’ lamps; 6: Picture lamp fragment; 7–8: wheel-made lamps; 9: provincial Loeschcke type II lamp; 10: imported Loeschcke type I lamp with inscription; 11: provincial Loeschcke type I lamp.

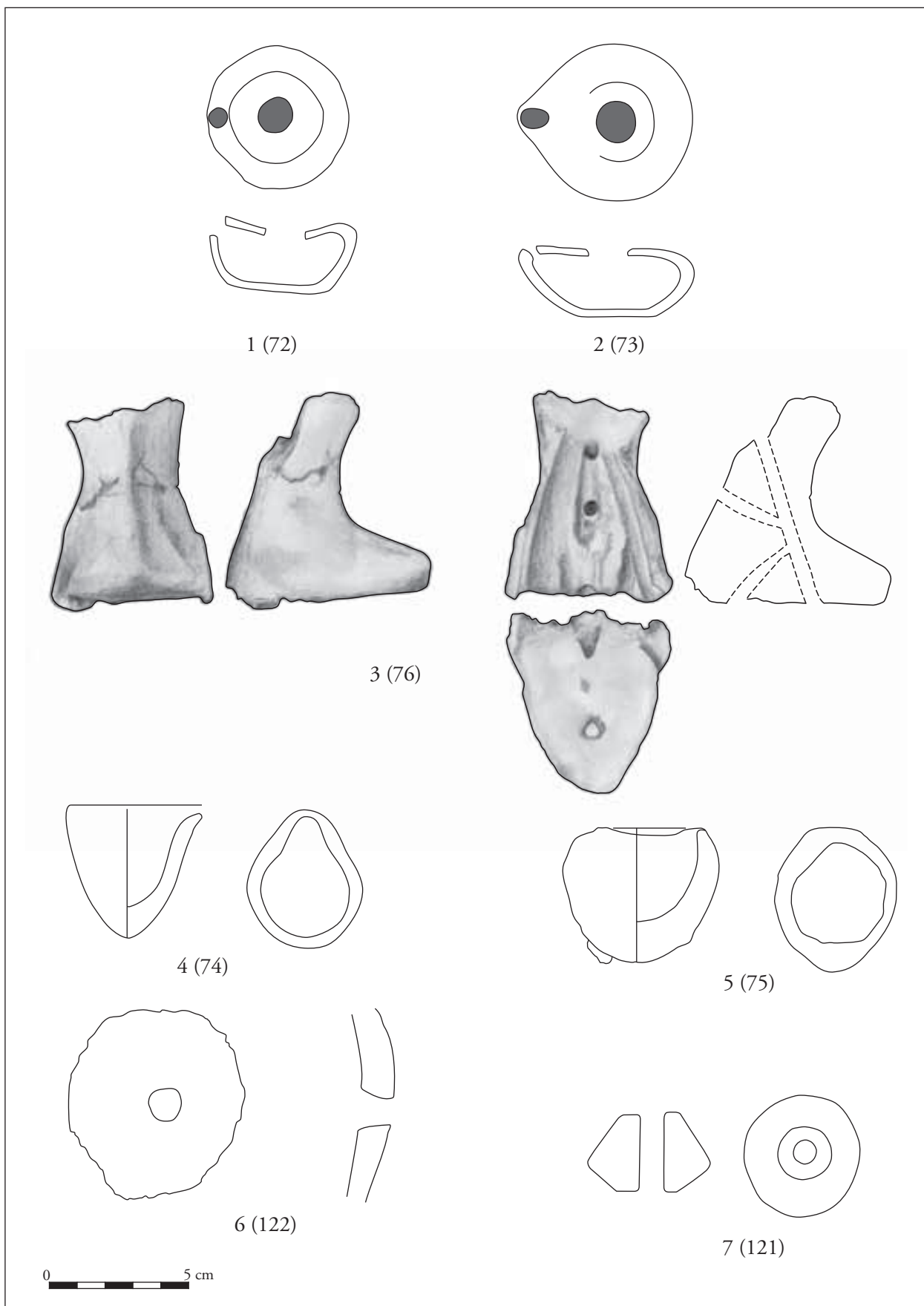

Pl. 32. Small finds discovered between 1971 and 1976. 1–2: wheel-made lamps; 3: bronze casting mould fragment; 4–5: crucibles; 6–7: spindle whorls. The catalogue numbers are given in brackets.



Pl. 33. Small finds discovered between 1971 and 1976. 1: pottery counters; 2: bronze casting mould fragment; 3: pottery and stone sling-shots. The catalogue numbers are given in brackets.



Pl. 34. Terracotta (pipeclay) figurine depicting the goddess Venus. The catalogue number is given in brackets.

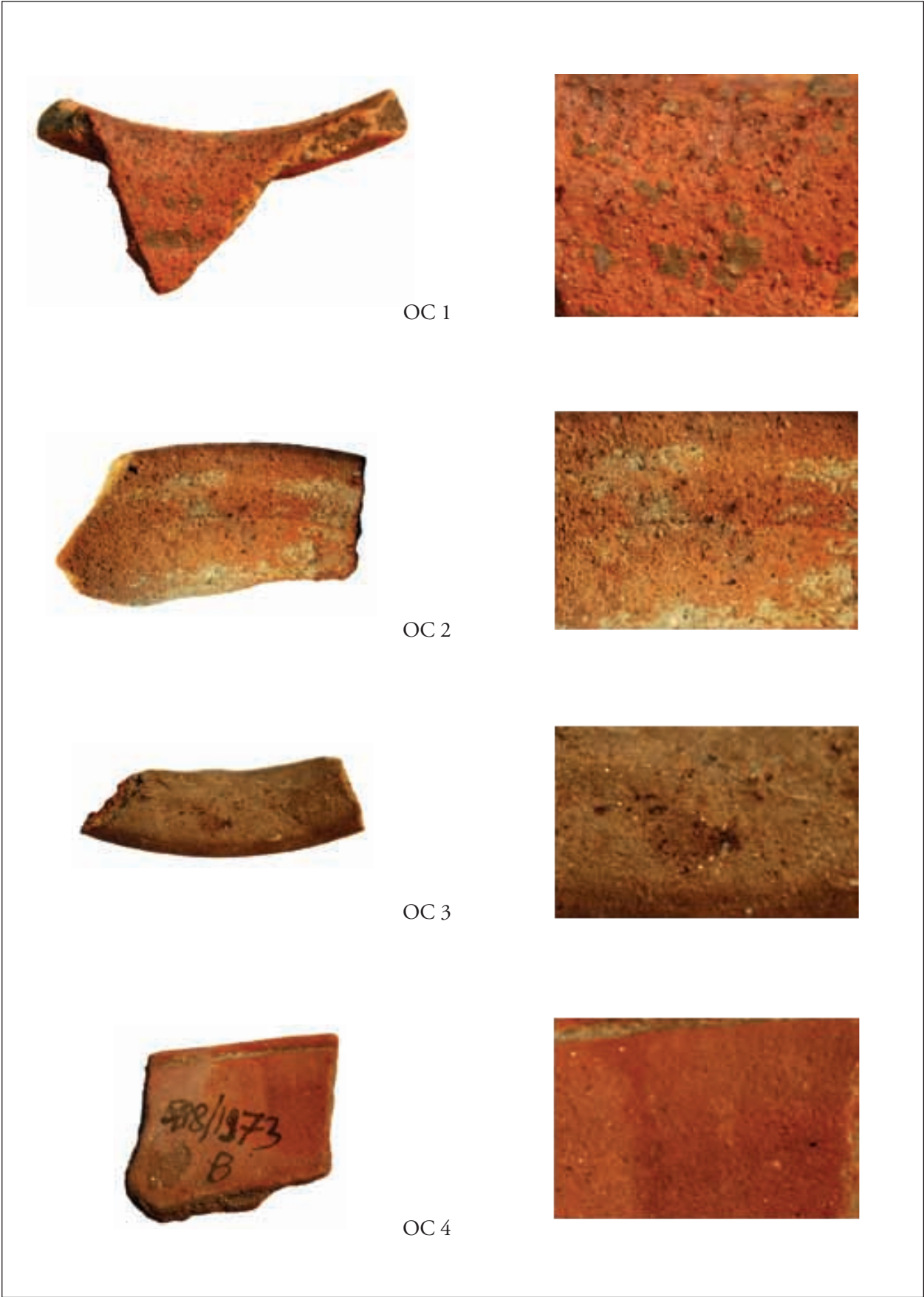

Pl. 35. The classification of the oxidized coarse (OC) fabrics.



OC 5

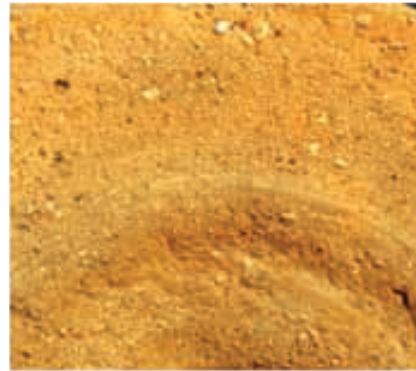

OC 6

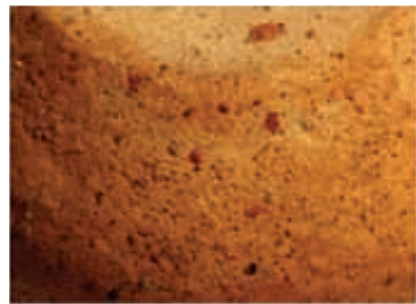

OS 1



OS 2



Pl. 36. The classification of the oxidized coarse (OC) and oxidized semifine (OS) fabrics.



OS 3



OS 4



OF 1



OF 2



Pl. 37. The classification of the oxidized semifine (OS) and oxidized fine (OF) fabrics.



OF 3



OF 4



RC 1



RC 2



Pl. 38. The classification of the oxidized fine (OF) and reduced coarse (RC) fabrics.

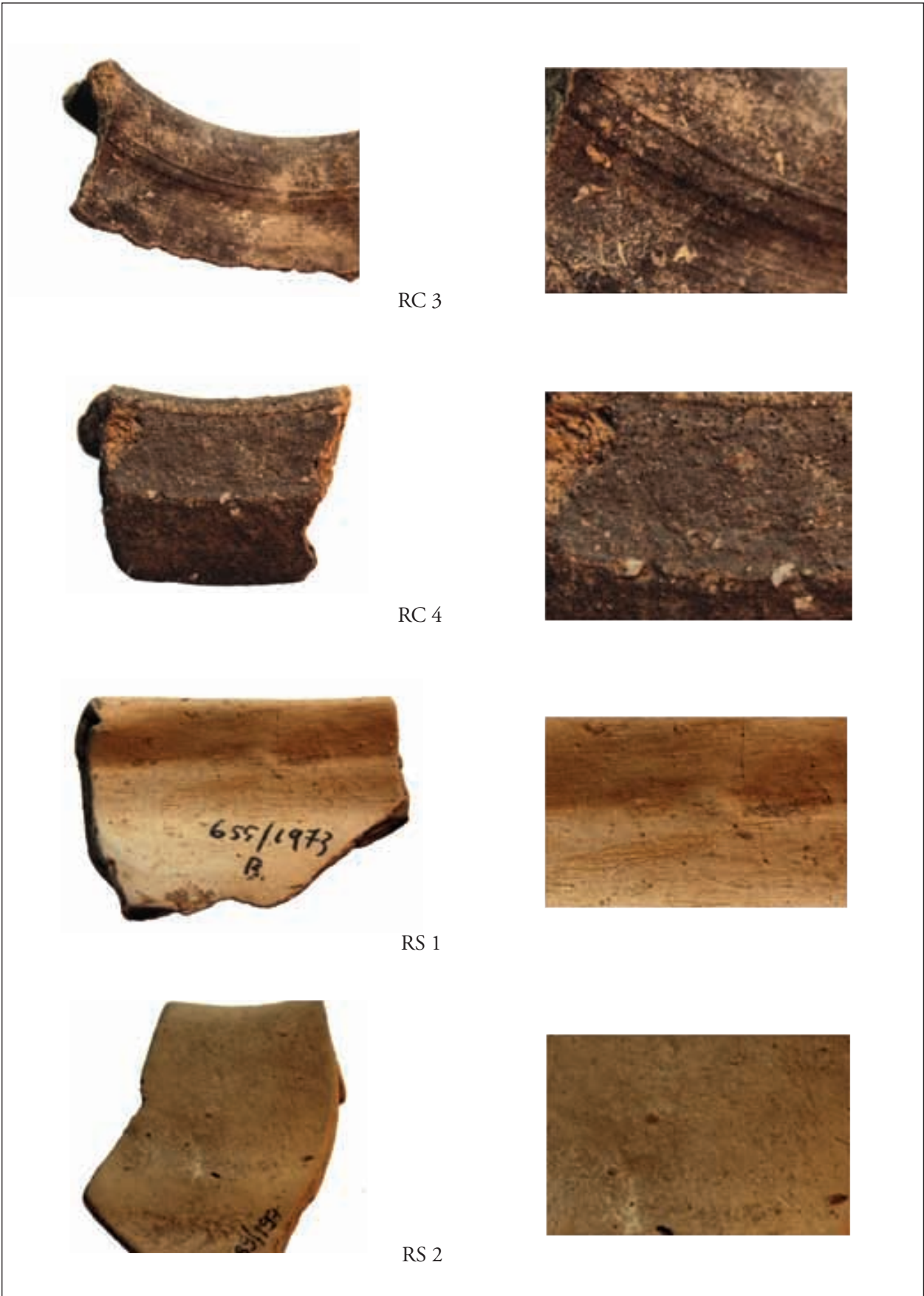

Pl. 39. The classification of the reduced coarse (RC) and reduced semifine (RS) fabrics.



RF 1



RF 2



RF 3



Pl. 40. The classification of the reduced fine (RF) fabrics.

